

## 26-40GHz Low Noise Amplifier

### GaAs Monolithic Microwave IC

#### Description

The CHA2362-98F is a wide band monolithic Low Noise monolithic Amplifier which integrates three amplification stages that produces 23dB gain associated to 2dB noise figure.

It is designed for a wide range of applications, from military to commercial communication systems.

The circuit is manufactured with a pHEMT process 0.1 $\mu$ m gate length, via holes through the substrate, air bridges and electron beam gate lithography.

It is available in chip form.

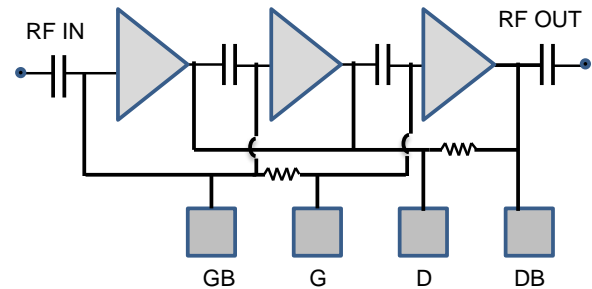

#### Main Features

- Freq: 26-40 GHz
- 22dB linear gain
- 2dB noise figure
- 9dBm output power at 1dB gain compression
- 21dBm OIP3
- DC bias: Vd=4 Volt@ Id= 65 mA
- Chip size 3x1.68x0.07mm

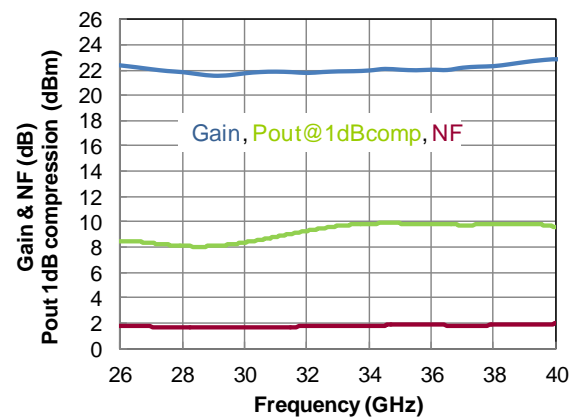

#### Main Electrical Characteristics

Tamb.= +25°C

Symbol	Parameter	Min	Typ	Max	Unit
Freq	Frequency range	26		40	GHz
Gain	Linear Gain		22		dB
NF	Noise Figure		2		dB
Op1dB	Output Power @1dB comp.		9		dBm

### Electrical Characteristics

Tamb.= +25°C. Vd = +4V; GB set in order to get Idq = 65mA

Symbol	Parameter	Min	Typ	Max	Unit
Freq	Frequency range	26		40	GHz
Gain	Linear Gain		22		dB
ripple	Ripple pic/pic in the frequency range		1.4		dB
NF	Noise Figure		2		dB
RLin	Input Return loss		13		dB
RLout	Output Return loss		13		dB
Op1dB	Output power at 1dB gain compression		9		dBm
OIP3	Output power at 3rd order intercept point		21		dBm
Vd	Drain supply voltage		4		V
Id	Drain supply current		65		mA
Vg	Gate supply voltage		-1		V
Ig	Gate supply current		1.3		mA

These values are representative of measurements done in test fixture with a bonding wire of typically 0.2 to 0.25nH.

**Absolute Maximum Ratings** <sup>(1)</sup>

Tamb.= +25°C

Symbol	Parameter	Max rating	Unit
Vd	Drain bias voltage	6	V
Id	Drain bias current	115	mA
Vg	Gate bias voltage	-3.5 to +0.15	V
Pin	Maximum peak input power overdrive	+15	dBm
Tj	Junction temperature	175	°C
Tstg	Storage temperature range	-55 to +150	°C

<sup>(1)</sup> Operation of this device above anyone of these parameters may cause permanent damage.

**Temperature Range**

Ta	Operating temperature range	-40 to +95	°C
Tstg	Storage temperature range	-55 to +150	°C

**Typical Bias Conditions**

Tamb.= +25°C

Symbol	Pad N°	Parameter	Values	Unit
D & DB	V1	DC drain voltage	4	V
GB	V2	DC gate voltage	-1	V

## Typical on-wafer Sij parameters

Tamb.= +25°C. Vd = +4.0V. Id = 65mA

Freq (GHz)	S11 (dB)	PhS11 (°)	S12 (dB)	PhS12 (°)	S21 (dB)	PhS21 (°)	S22 (dB)	PhS22 (°)
0.50	-0.25	-18.95	-60.88	-47.06	-30.86	-150.56	-0.78	-32.67
2.00	-0.90	-68.60	-60.89	57.43	-38.24	52.12	-1.41	-108.11
3.00	-1.39	-94.03	-70.94	-66.56	-43.60	34.29	-2.30	-143.49
8.00	-2.18	-167.89	-63.13	162.14	-40.42	2.32	-11.73	152.33
9.00	-2.22	-178.56	-62.47	-131.95	-33.98	-1.81	-12.13	157.50
10.00	-2.16	171.29	-64.49	-53.74	-28.79	-16.80	-11.92	157.15
11.00	-2.20	161.50	-64.91	116.50	-24.65	-30.93	-11.83	154.94
12.00	-2.32	150.74	-59.38	103.18	-20.42	-41.87	-12.11	150.19
13.00	-2.30	139.35	-59.01	174.78	-15.90	-53.78	-11.91	145.07
14.00	-2.46	127.43	-61.77	-133.31	-11.09	-69.05	-11.88	137.00
15.00	-2.62	114.23	-62.97	157.18	-6.32	-89.15	-12.25	125.75
16.00	-3.06	99.57	-79.62	39.67	-1.96	-112.67	-12.68	113.95
17.00	-3.69	84.55	-65.89	-56.73	2.13	-139.67	-13.54	98.88
18.00	-4.45	68.11	-59.31	85.52	5.68	-168.20	-14.81	78.65
19.00	-5.16	50.56	-61.46	120.60	8.92	162.64	-16.19	53.56
20.00	-6.28	30.05	-58.09	105.87	11.97	132.59	-17.75	18.90
21.00	-6.96	5.50	-48.08	96.41	14.91	101.35	-17.94	-26.31
22.00	-8.26	-21.12	-50.55	61.00	17.40	68.15	-16.91	-65.54
23.00	-8.80	-55.89	-45.80	39.45	19.75	32.90	-15.87	-98.20
24.00	-9.56	-90.88	-53.03	-46.26	21.48	-4.14	-15.50	-124.12
25.00	-10.22	-128.34	-48.73	-15.16	22.59	-41.67	-16.50	-138.11
26.00	-10.56	-159.44	-42.19	-52.34	23.19	-77.72	-17.49	-143.57
27.00	-11.56	165.50	-47.73	-71.09	23.41	-111.53	-15.78	-143.84
27.50	-12.11	152.98	-47.28	-102.79	23.44	-127.59	-15.28	-148.10
28.00	-11.47	140.12	-48.01	-115.54	23.42	-143.24	-15.02	-151.28
29.00	-13.51	112.84	-52.40	-93.72	23.33	-173.54	-14.03	-167.17
30.00	-13.50	83.25	-54.55	-108.05	23.10	158.11	-14.04	173.87
31.00	-15.42	59.26	-51.76	156.73	22.95	130.67	-14.56	153.41
32.00	-16.08	33.99	-50.69	159.52	22.85	104.27	-15.43	129.73
33.00	-16.58	11.85	-46.23	111.96	22.73	77.91	-16.15	98.60
34.00	-16.40	-2.00	-46.40	130.47	22.67	52.51	-16.98	60.99
35.00	-17.29	-22.26	-46.02	123.80	22.61	26.45	-15.77	21.56
36.00	-17.01	-31.66	-46.33	69.90	22.57	0.65	-14.42	-3.17
37.00	-17.91	-34.37	-49.77	17.23	22.64	-25.75	-13.04	-29.22
38.00	-18.01	-40.52	-45.07	54.96	22.75	-52.57	-11.88	-45.11
39.00	-15.90	-33.11	-47.67	16.24	22.80	-82.04	-12.60	-56.70
40.00	-15.08	-28.84	-47.46	-8.27	22.90	-115.34	-12.81	-52.83
41.00	-12.31	-36.07	-48.50	-22.07	22.23	-155.67	-9.69	-31.33
42.00	-11.07	-40.01	-46.36	-106.34	19.26	159.20	-4.76	-41.41

**Device thermal performances**

All the figures given in this section are obtained assuming that the device is only cooled down by conduction through the package thermal pad (no convection mode considered).

The temperature is monitored at the MMIC back-side interface (Tcase).

The system maximum temperature must be adjusted in order to guarantee that Tjunction remains below the maximum value specified in the Absolute Maximum Ratings table.

So, the system PCB must be designed to comply with this requirement.

Parameter	Biasing conditions	Tjunction (°C)	RTH (°C/W)	T50 (hours)
RTH <sup>(1)</sup> Thermal Resistance ( Junction to Case)	Vd= 4V Id= 65mA Pdiss=0.263W	91	20.5	5e <sup>11</sup>

(1) Assuming 85°C Tcase

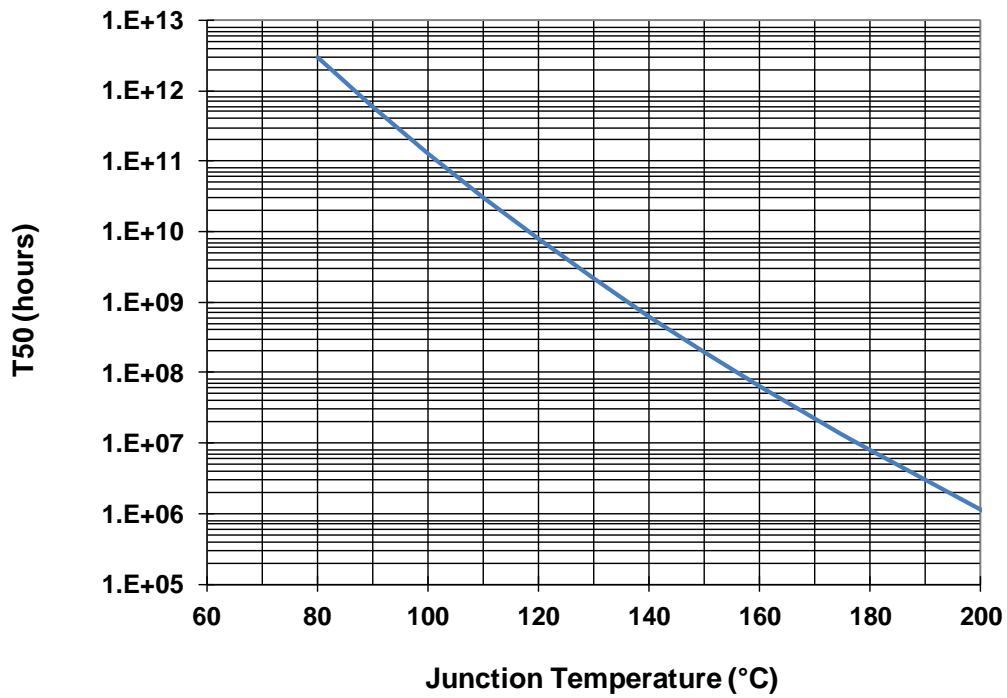

## Typical Board Measurements at ambient temperature

Tamb.= +25°C, Vd = 4V, Idq = 65mA

The following values are representative of on board measurements, on die access planes

### Gain and Return losses

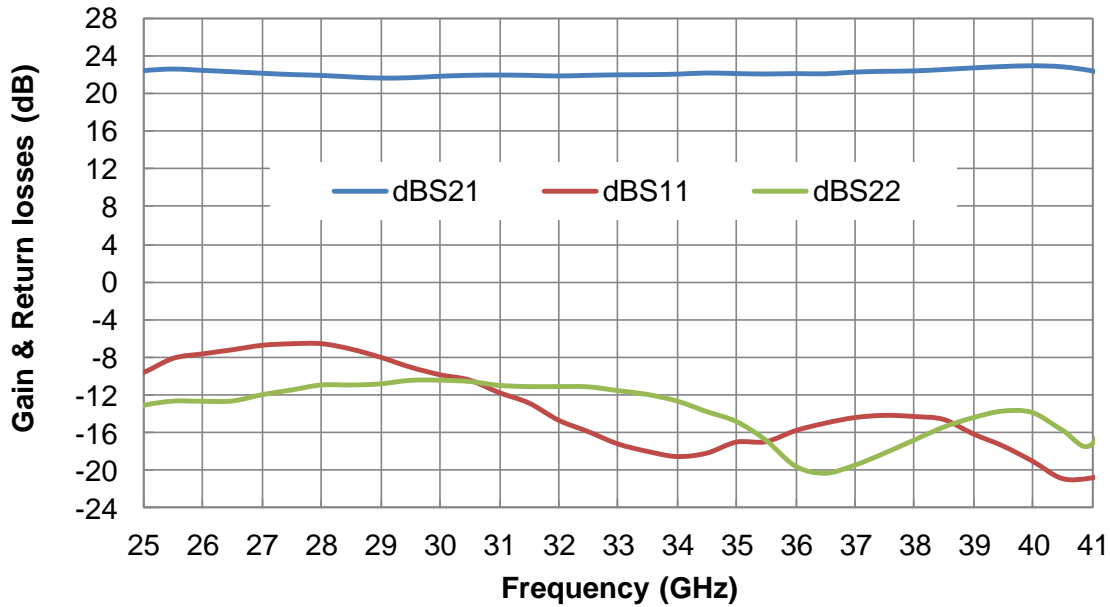

### Noise Figure

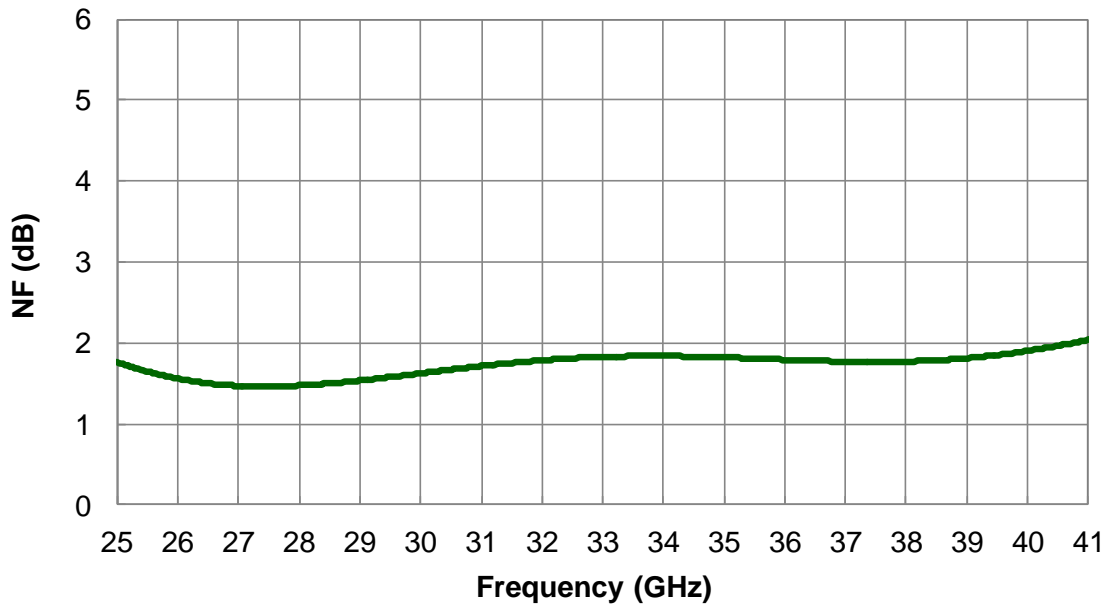

**Typical Board Measurements at ambient temperature**

Tamb.= +25°C, Vd = 4V, Idq = 65mA

The following values are representative of on board measurements, on die access reference planes

**Output power at 1 dB gain compression**

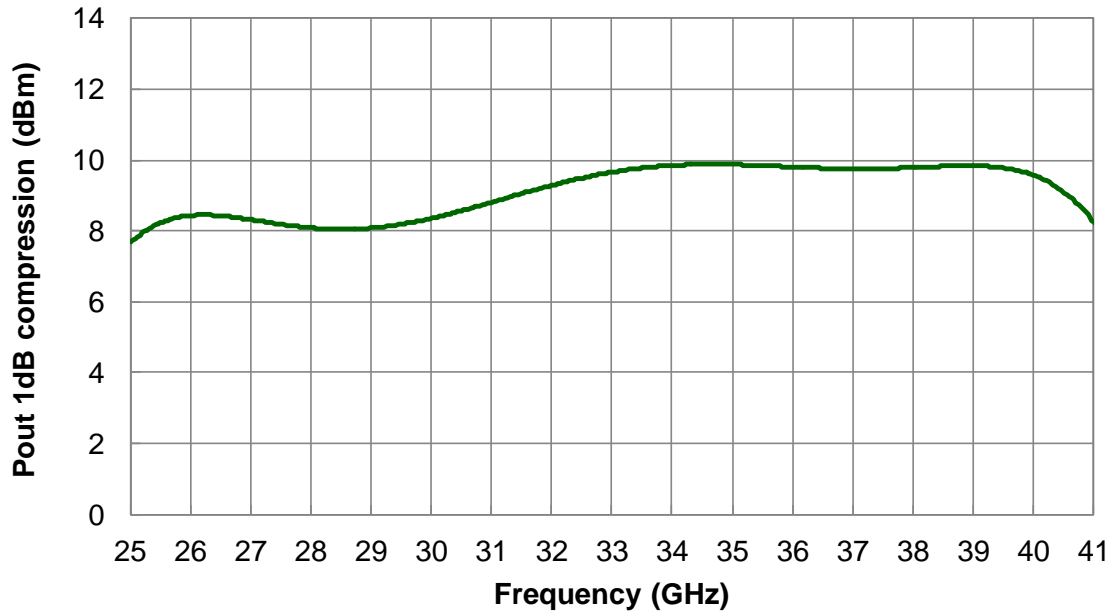

**Output IP3**

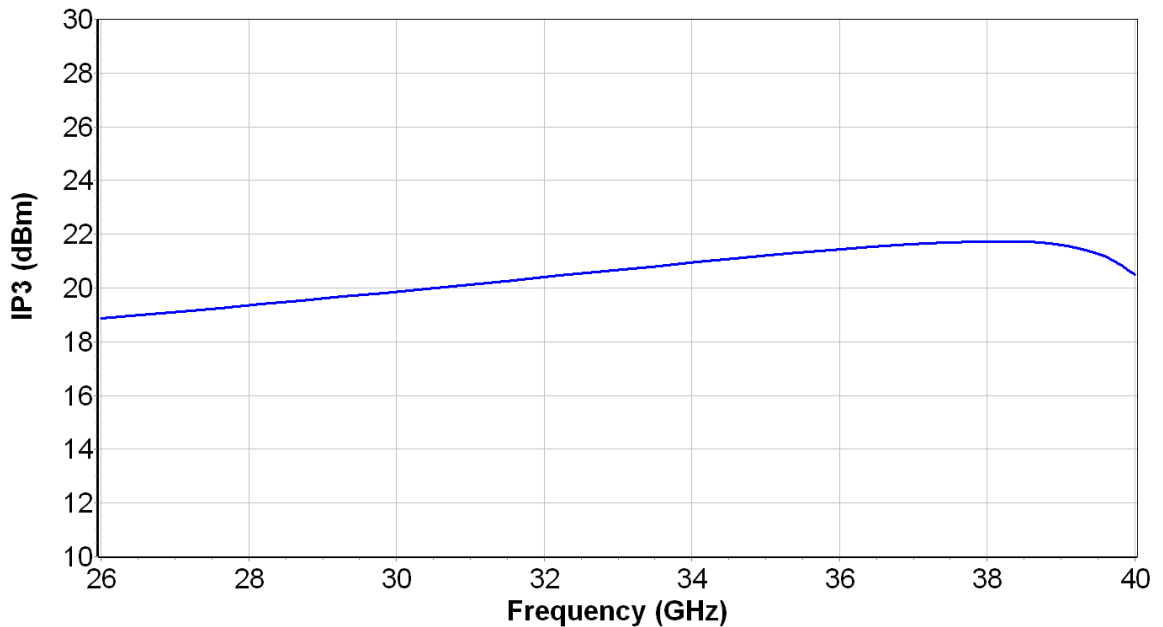

## Typical Board Measurements versus temperature

Tamb.= +25°C, Vd = 4V, Idq = 65mA

The following values are representative of on board measurements, on die access planes

### Linear Gain versus temperature

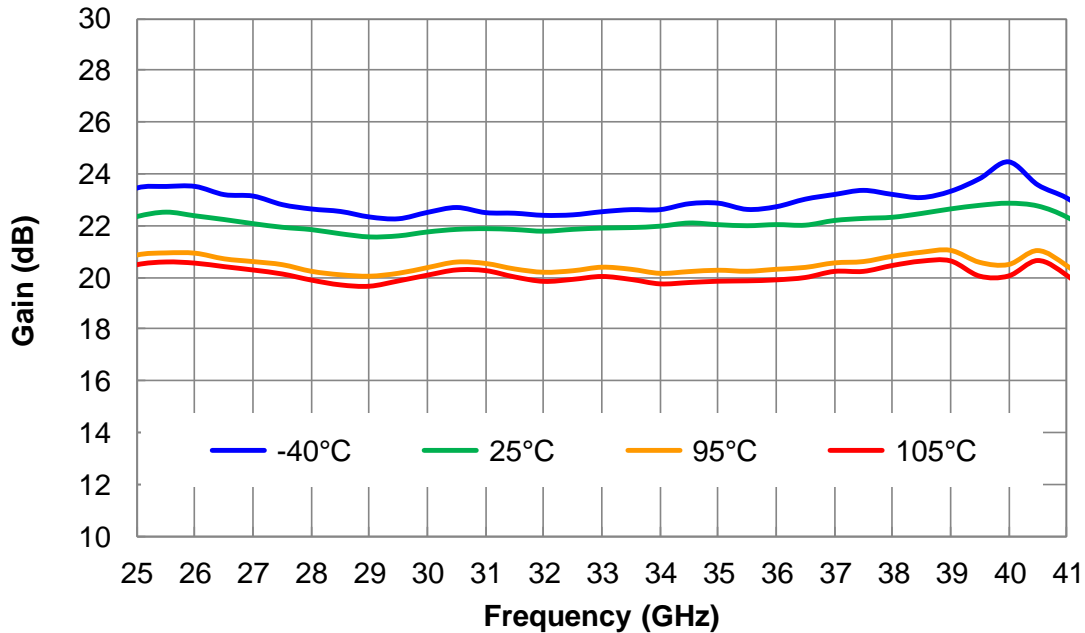

### Noise Figure versus temperature

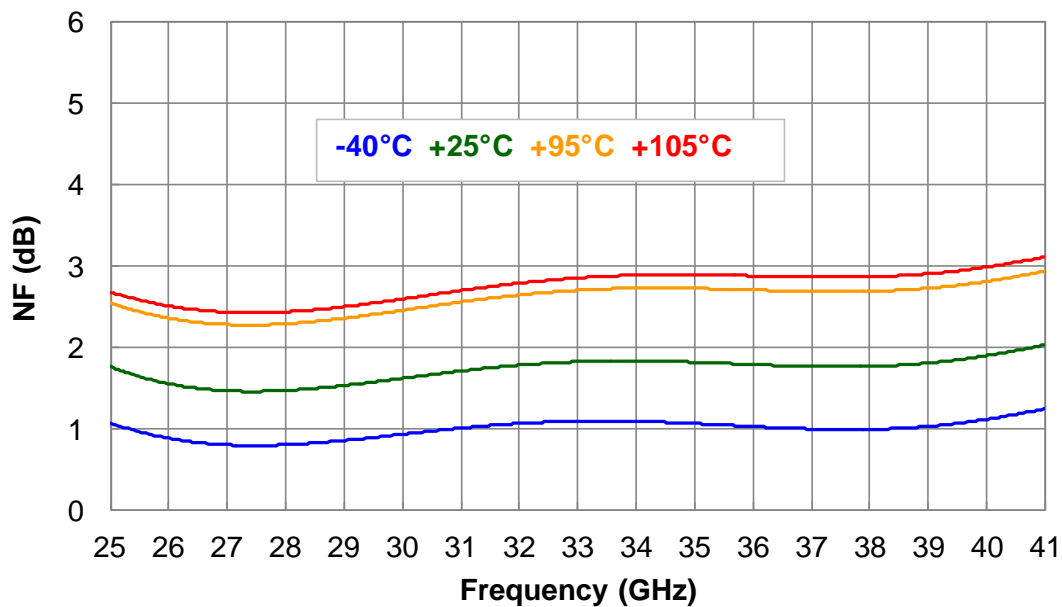



**Typical Board Measurements versus temperature**

Tamb = +25°C, Vd = +4V, Idq = 65mA

The following values are representative of on board measurements, on die access planes

**Output power at 1dB compression versus temperature**

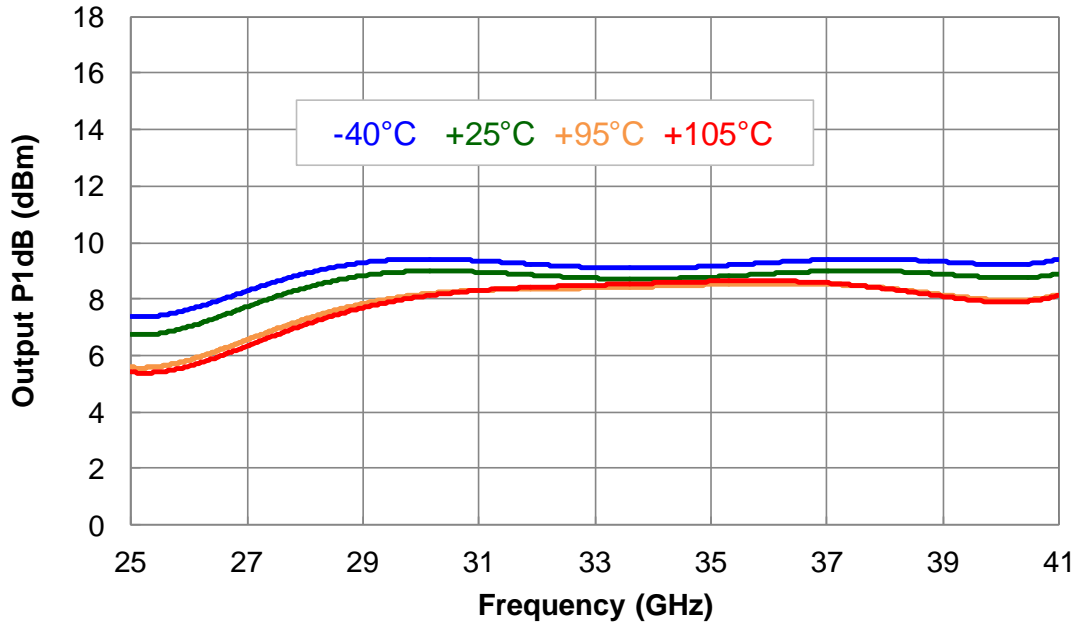

**Output C/I3 at 26GHz versus temperature at 65mA**

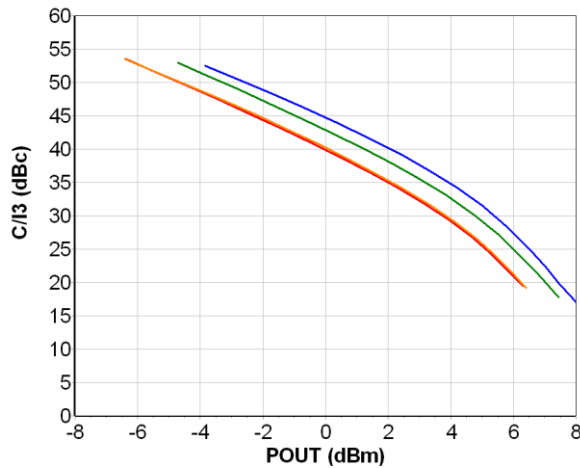

**Output C/I3 at 40GHz versus temperature at 65mA**

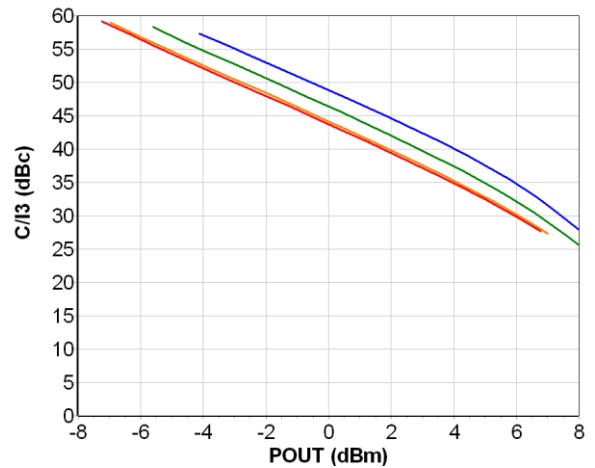

## Mechanical data

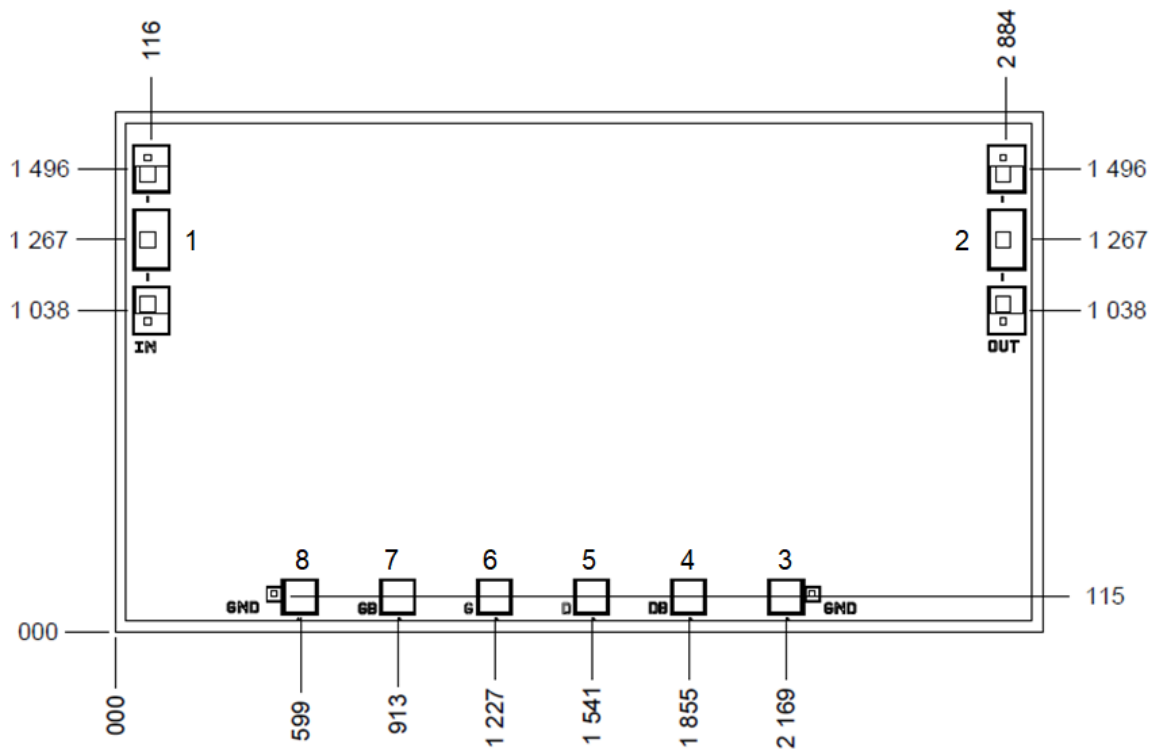

Chip thickness: 70µm.  
 Chip size: 3000/1680 ±35µm  
 All dimensions are in micrometers

RF Pads (1,2) = 186 x 105 (BCB opening)  
 DC Pads = 100 x 100 (BCB opening)

PAD Number	Name	Description
1	RF IN	Input RF port
2	RF OUT	Output RF port
3, 8	GND	ground
7	GB	DC Gate voltage <sup>(1)</sup>
4, 5	DB, D	DC Drain voltage <sup>(1)</sup>

<sup>(1)</sup> Pad number 6: G is not used

**Recommended assembly plan**

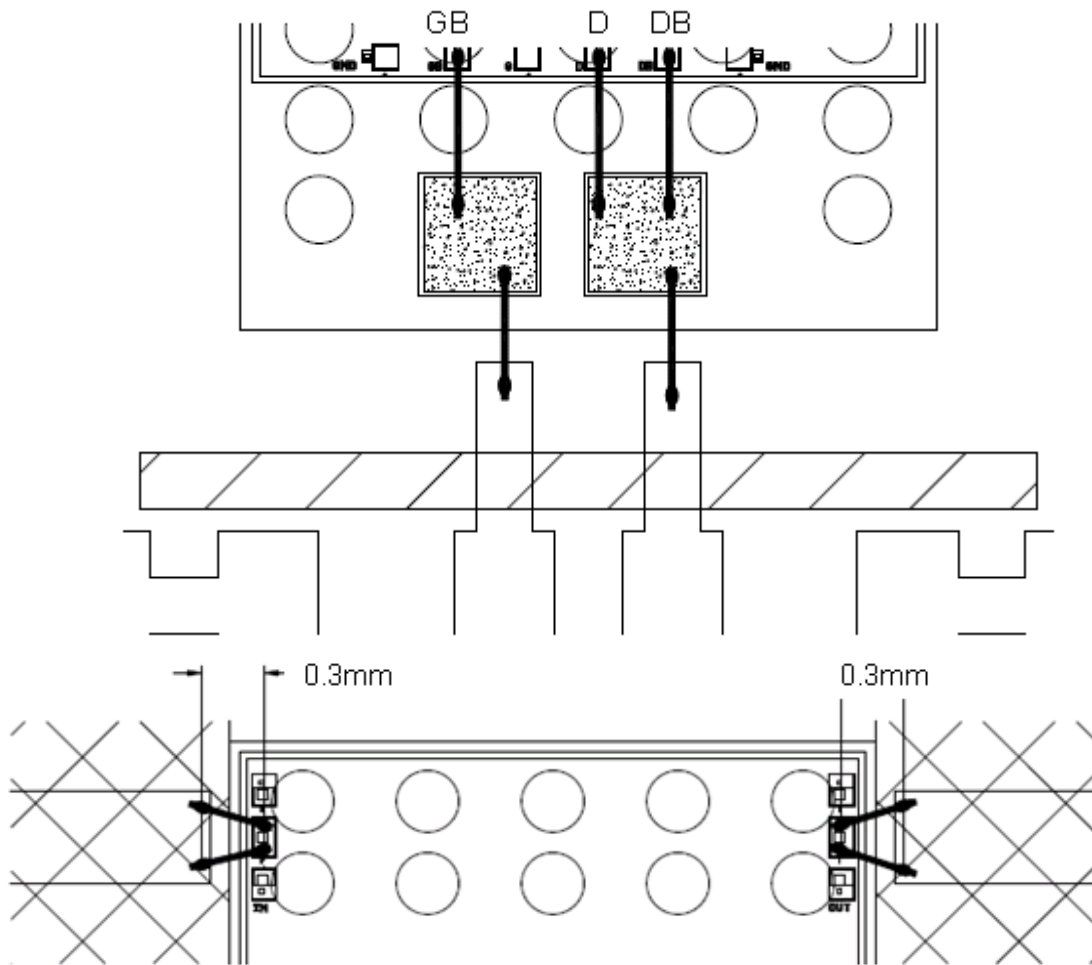

Note: Supply feed should be bypassed. 25µm diameter gold wire is to be preferred.

**Recommended circuit bonding table**

Label	Type	Decoupling	Comment
D, DB	Vd	120pF, 10nF& 1µF	Drain Supply
GB	Vg	120pF, 10nF& 1µF	Gate Supply

## Evaluation mother board

- Based on typically Ro4003 / 8mils or equivalent.
- Decoupling capacitors of 120pF, 10nF  $\pm 10\%$  and 1 $\mu$ F  $\pm 10\%$  are recommended for all DC accesses.
- Note: All board measurements are performed using shielded cables. even for DC bias. to ensure safe operation.

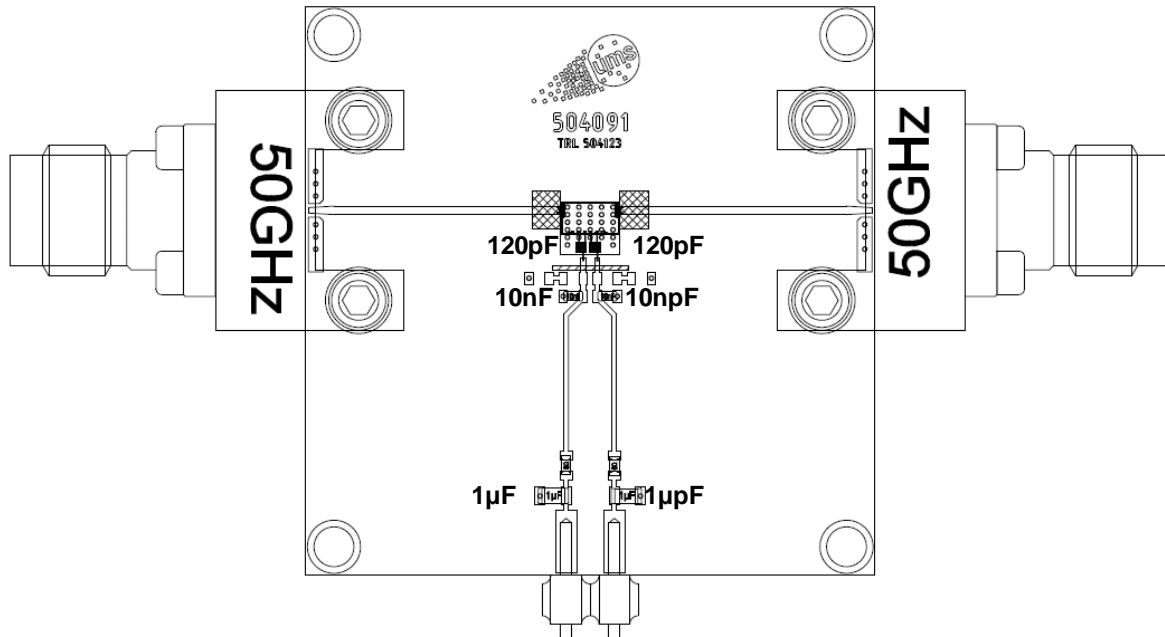

DC Schematic

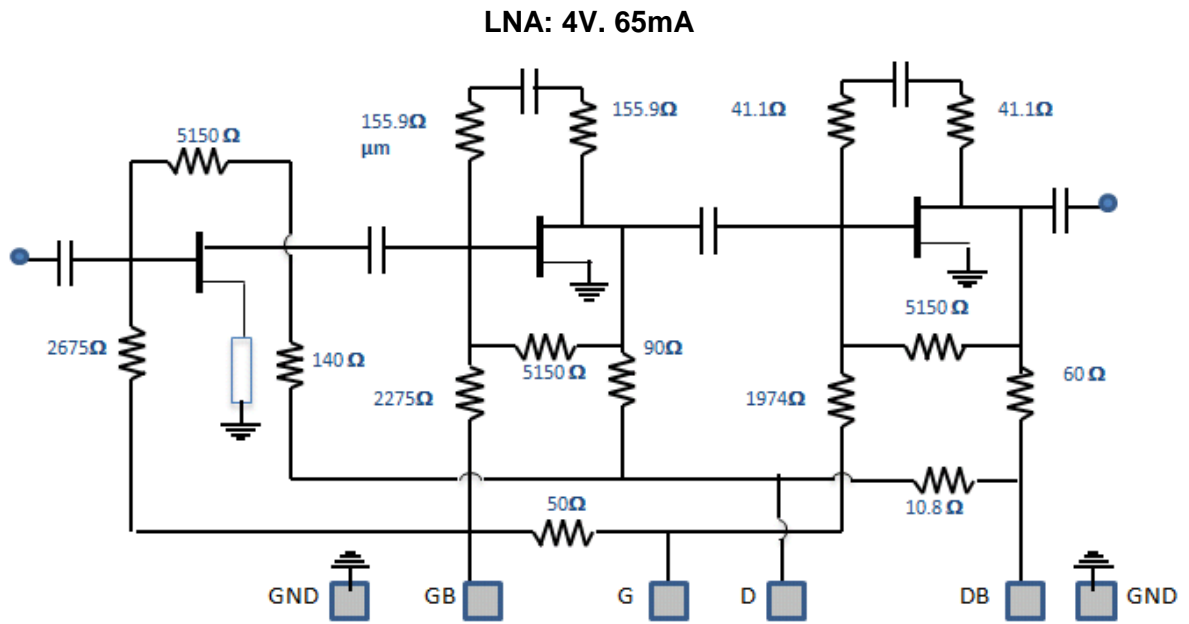

### Recommended ESD management

Refer to the application note AN0020 available at <http://www.ums-gaas.com> for ESD sensitivity and handling recommendations for the UMS products.

### Recommended environmental management

UMS products are compliant with the regulation in particular with the directives RoHS N°2011/65 and REACH N°1907/2006. More environmental data are available in the application note AN0019 also available at <http://www.ums-gaas.com>.

## Ordering Information

Chip form:

CHA2362-98F/00

Information furnished is believed to be accurate and reliable. However **United Monolithic Semiconductors S.A.S.** assumes no responsibility for the consequences of use of such information nor for any infringement of patents or other rights of third parties which may result from its use. No license is granted by implication or otherwise under any patent or patent rights of **United Monolithic Semiconductors S.A.S.** Specifications mentioned in this publication are subject to change without notice. This publication supersedes and replaces all information previously supplied. **United Monolithic Semiconductors S.A.S.** products are not authorised for use as critical components in life support devices or systems without express written approval from **United Monolithic Semiconductors S.A.S.**