

17-24GHz Medium Power Amplifier

GaAs Monolithic Microwave IC

Description

The CHA5350-99F is a four stage monolithic MPA that typically provides an output power of 26.5dBm at 1dB gain compression associated to a high IP3 output of 34dBm.

It is designed for a wide range of applications, from professional to commercial communication systems.

The circuit is manufactured with a pHEMT process, 0.15µm gate length, via holes through the substrate, air bridges and electron beam gate lithography.

It is available in chip form.

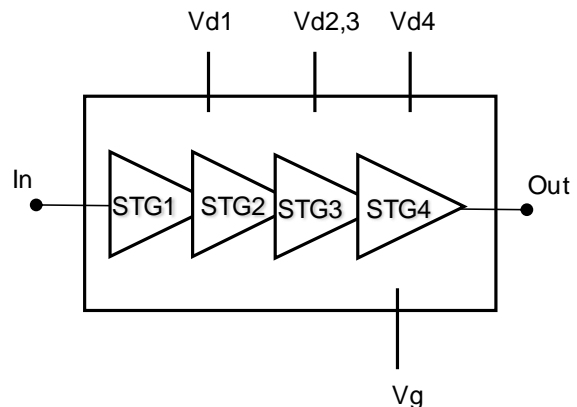

Main Features

- Broadband performances: 17-24GHz
- Linear gain = 26dB
- Pout = 26.5dBm @ 1dB comp.
- High OIP3 = 34dBm
- DC bias: Vd=6Volt @ Id=300mA
- Chip size 2.38x1.46x0.07mm

Pout +IP3

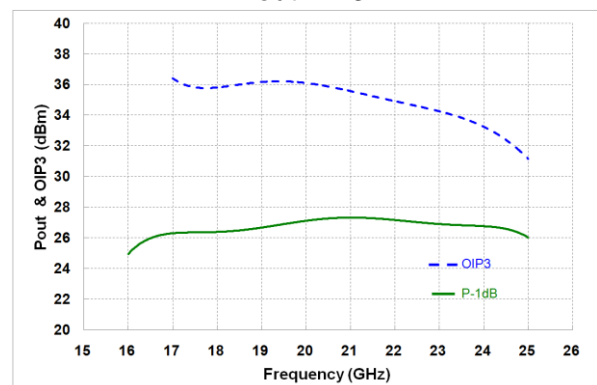

Main Electrical Characteristics

Tamb.= +25°C

Symbol	Parameter	Min	Typ	Max	Unit
Freq	Frequency range	17		24	GHz
Gain	Linear Gain		26		dB
P _{-1dB}	Output Power @1dB gain compression		26.5		dBm
OIP3	Output third order interception point		34		dBm

Electrical Characteristics

Tamb.= +25°C, Vd_{1,2,3,4} = +6V, Idq = 300mA

Symbol	Parameter	Min	Typ	Max	Unit
Freq	Frequency range	17		24	GHz
Gain	Linear Gain		26		dB
Gain_T	Linear gain variation versus temperature		-0.035		dB/°C
RLin	Input Return Loss		-17		dB
RLout	Output Return Loss		-12		dBm
P _{-1dB}	Output Power @1dB gain compression		26.5		dBm
P _{sat}	Saturated output power		27		dBm
PAE_P _{-1dB}	Power added efficiency @1dB gain comp.		25		%
Id_P _{-1dB}	Drain current @1dB gain compression		350		mA
Id_P _{sat}	Drain current @ saturation		400		mA
OIP3	Output third order interception point on the frequency range 17-21 GHz		35.5		dBm
	Output third order interception point on the frequency range 21-24 GHz		34		dBm
Vd _{1,2,3,4}	Drain supply voltage		6		V
Id	Drain quiescent current		300		mA
Vg	Gate supply voltage		-0.7		V

These values are representative of measurements in test fixture that are made with bonding wires at the RF ports.

Wire bonding at RF accesses: 0.3nH, typically.

Absolute Maximum Ratings ⁽¹⁾T_{amb.} = +25°C

Symbol	Parameter	Values	Unit
V _{d1,2,3,4}	Drain bias voltage	8V	V
I _d	Drain bias current ⁽¹⁾	650	mA
V _g	Gate bias voltage	-2 to -0.3	V
P _{in}	Maximum peak input power overdrive ⁽²⁾	+15	dBm
T _j	Junction temperature	175	°C
T _a	Operating temperature range	-40 to +85	°C
T _{stg}	Storage temperature range	-55 to +150	°C

⁽¹⁾ Operation of this device above anyone of these parameters may cause permanent damage.

⁽²⁾ Duration < 1s.

Typical Bias ConditionsT_{amb.} = +25°C

Symbol	Pad N°	Parameter	Values	Unit
V _g	10	DC gate Voltage	-0.7	V
V _{d1,2,3,4}	3, 5, 7	DC drain Voltage	6	V
I _d		DC Drain current controlled with V _g ⁽¹⁾	300	mA

⁽¹⁾ To be adjusted in order to achieve I_d: 300mA

Typical on-wafer Sij parameters

Tamb.= +25°C, Vd_{1,2,3,4} = +6V, Id = 300mA

Freq (GHz)	S11 (dB)	PhS11 (°)	S12 (dB)	PhS12 (°)	S21 (dB)	PhS21 (°)	S22 (dB)	PhS22 (°)
2.0	-0.07	-9.44	-78.88	159.60	-52.68	72.93	-0.85	-75.67
3.0	-0.14	-18.26	-68.51	81.71	-49.70	-125.90	-0.53	-122.60
4.0	-0.18	-27.23	-79.86	53.21	-35.51	96.97	-0.43	-146.70
5.0	-0.19	-36.57	-87.07	-177.80	-41.13	-22.73	-0.34	-167.70
6.0	-0.35	-46.92	-78.25	89.10	-42.71	-47.59	-0.38	176.80
7.0	-0.45	-54.72	-75.64	-123.20	-29.13	-141.00	-0.40	163.80
8.0	-0.41	-65.00	-68.15	-112.30	-23.35	148.90	-0.46	150.80
9.0	-0.48	-75.90	-63.28	155.10	-18.62	93.87	-0.62	137.90
10.0	-0.61	-88.48	-71.90	-167.70	-14.08	44.06	-0.87	124.80
11.0	-0.94	-102.00	-73.31	-84.77	-9.38	-2.71	-1.22	110.90
12.0	-1.62	-118.40	-65.53	-177.50	-4.54	-49.34	-1.66	96.05
13.0	-2.78	-136.00	-66.25	93.70	0.68	-97.29	-2.23	79.67
14.0	-4.73	-155.60	-64.18	-155.30	6.29	-148.20	-3.06	61.16
15.0	-7.82	-178.90	-62.89	81.10	12.39	156.00	-4.09	39.87
16.0	-13.34	155.10	-66.33	99.71	19.16	89.99	-5.68	15.94
17.0	-24.98	93.42	-67.24	107.60	25.25	0.27	-8.59	-4.08
18.0	-22.61	4.93	-74.75	-58.96	26.56	-95.76	-9.80	-12.28
19.0	-15.63	-18.92	-63.85	118.40	25.89	-174.60	-9.73	-27.73
20.0	-12.39	-46.99	-65.04	66.25	25.24	118.50	-12.00	-40.32
21.0	-13.02	-66.87	-64.69	11.09	26.79	48.04	-12.44	-40.82
22.0	-13.46	-69.21	-53.18	102.10	26.76	-27.44	-11.63	-42.73
23.0	-15.49	-67.50	-61.36	-31.78	26.41	-102.50	-10.35	-43.71
24.0	-15.18	-49.01	-60.01	-130.60	25.77	-179.50	-7.83	-46.90
25.0	-15.06	-31.73	-53.04	179.10	24.54	100.50	-5.16	-59.34
26.0	-9.04	-8.19	-61.37	-154.70	23.17	12.93	-3.72	-76.60
27.0	-3.83	-36.15	-60.71	14.69	17.35	-88.24	-3.06	-91.44
28.0	-3.32	-58.66	-68.44	-21.18	8.69	-157.80	-2.63	-102.80
29.0	-3.67	-68.03	-55.10	-93.55	1.28	149.50	-2.39	-112.80
30.0	-3.16	-73.69	-61.90	85.85	-5.59	103.50	-2.25	-122.10
31.0	-3.18	-80.86	-57.37	153.70	-11.50	62.37	-2.05	-130.50
32.0	-2.57	-88.42	-75.25	-17.50	-17.32	23.99	-1.92	-136.50
33.0	-3.30	-90.72	-54.64	161.40	-22.56	-12.22	-1.81	-145.00
34.0	-3.07	-99.44	-48.99	37.95	-27.67	-44.97	-1.63	-152.40
35.0	-3.02	-100.70	-51.88	68.05	-32.94	-82.00	-1.78	-160.30
36.0	-2.93	-104.80	-53.91	41.18	-37.31	-106.10	-1.76	-166.30
37.0	-3.82	-108.60	-49.95	86.53	-40.50	-145.90	-1.72	-177.30
38.0	-3.49	-109.20	-59.92	28.09	-43.89	-157.80	-1.84	172.10
39.0	-4.14	-112.50	-55.74	99.34	-48.24	162.60	-1.86	160.70
40.0	-3.21	-116.50	-58.42	107.20	-60.58	118.40	-3.28	143.60

Typical Test Fixture Measurements

Vd_{1,2,3,4} = +6V, Idq = 300mA

Linear Gain & Return Losses versus Frequency

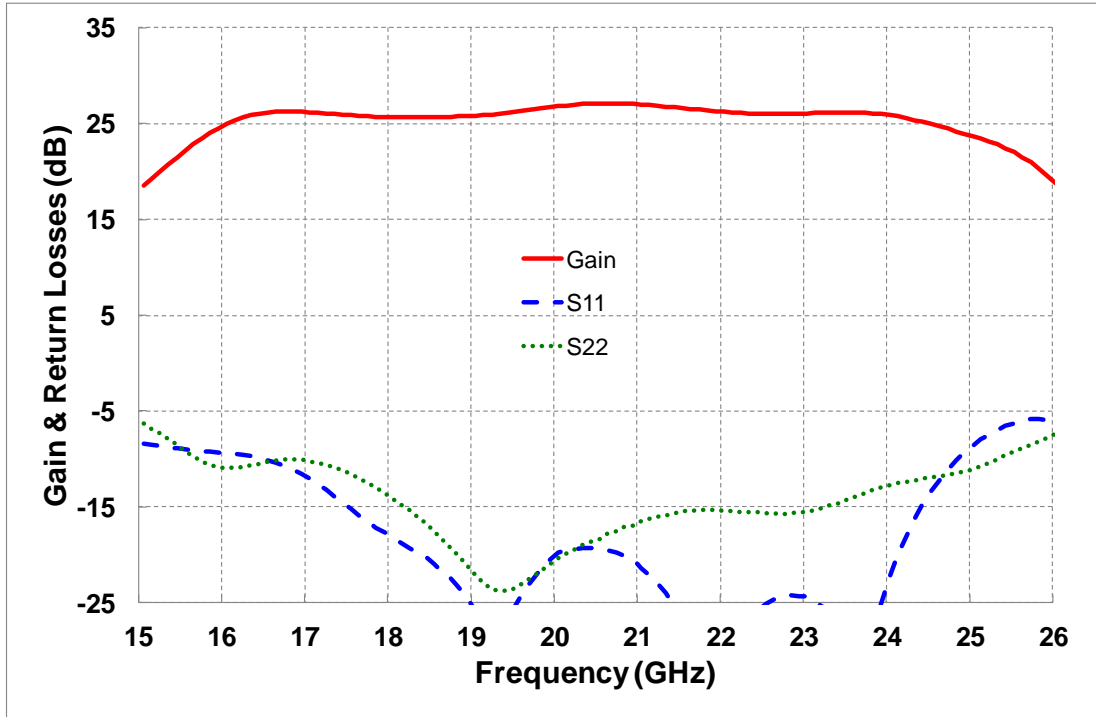

Linear Gain versus Frequency and Temperature

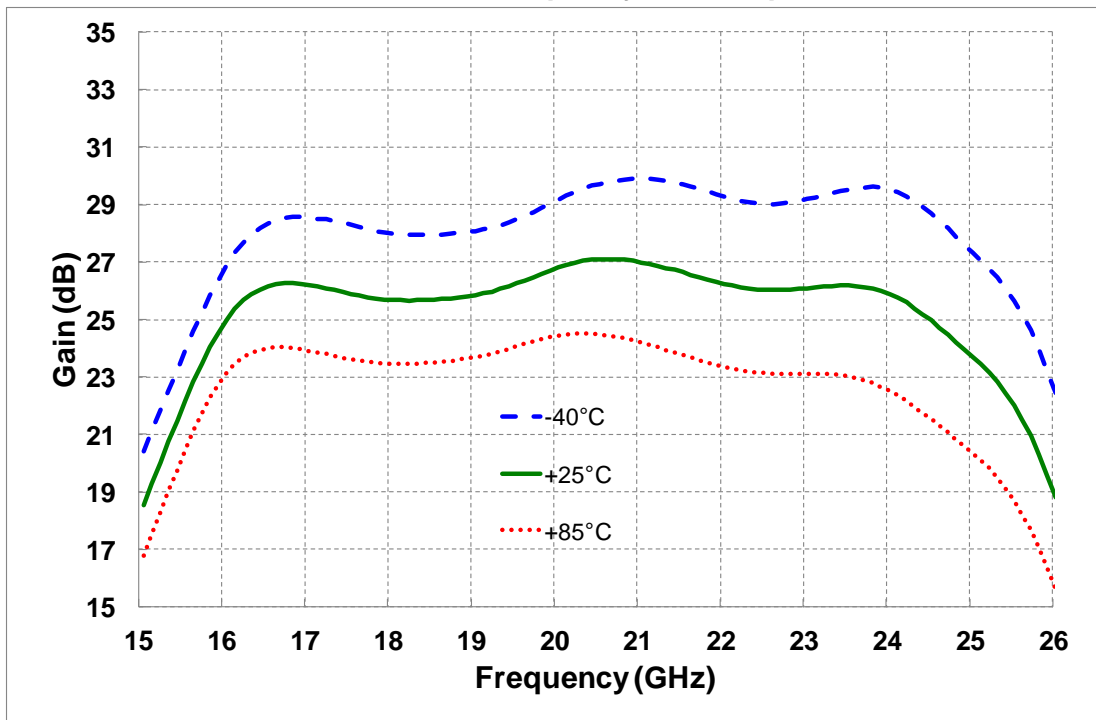

Typical Test Fixture Measurements

$V_{d1,2,3,4} = +6V$, $I_{dq} = 300mA$

Input Return Loss versus Frequency and Temperature

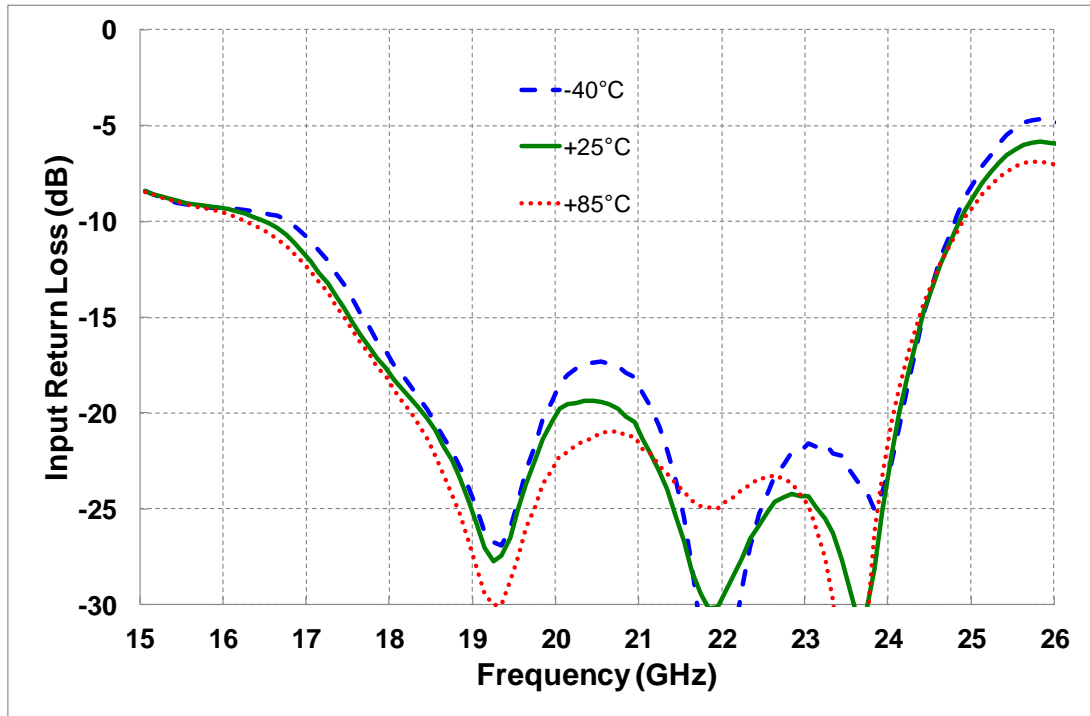

Output Return Loss versus Frequency and Temperature

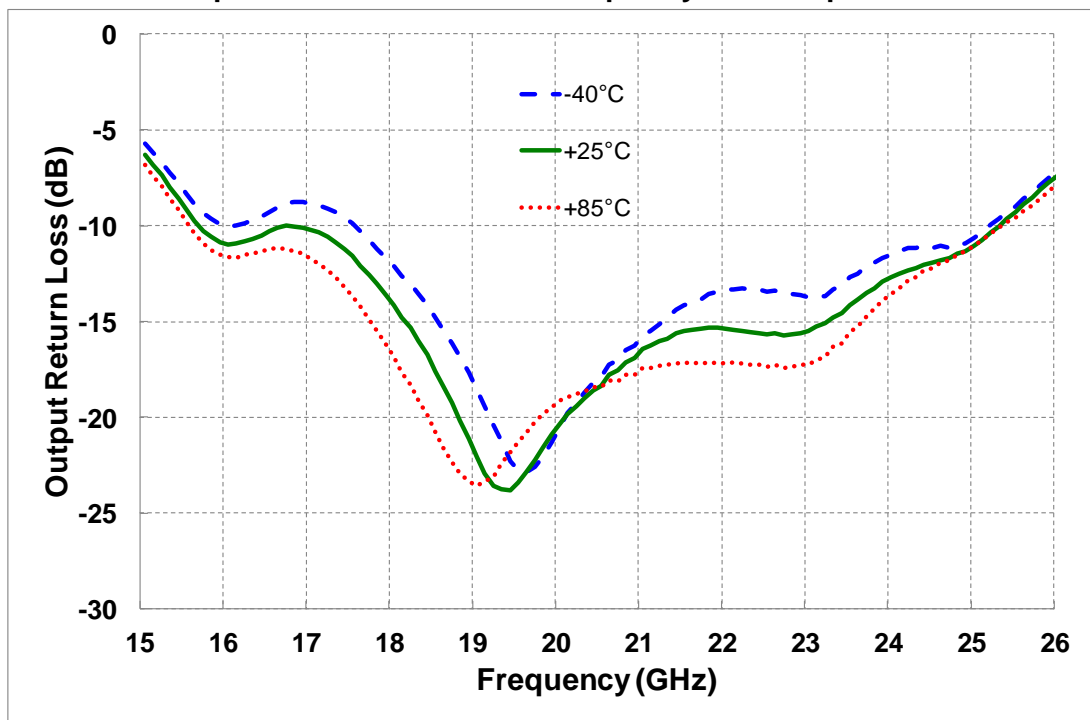

Typical Test Fixture Measurements

Vd_{1,2,3,4} = +6V, Idq = 300mA

Output Power @ 1dB Comp versus Frequency and Temperature

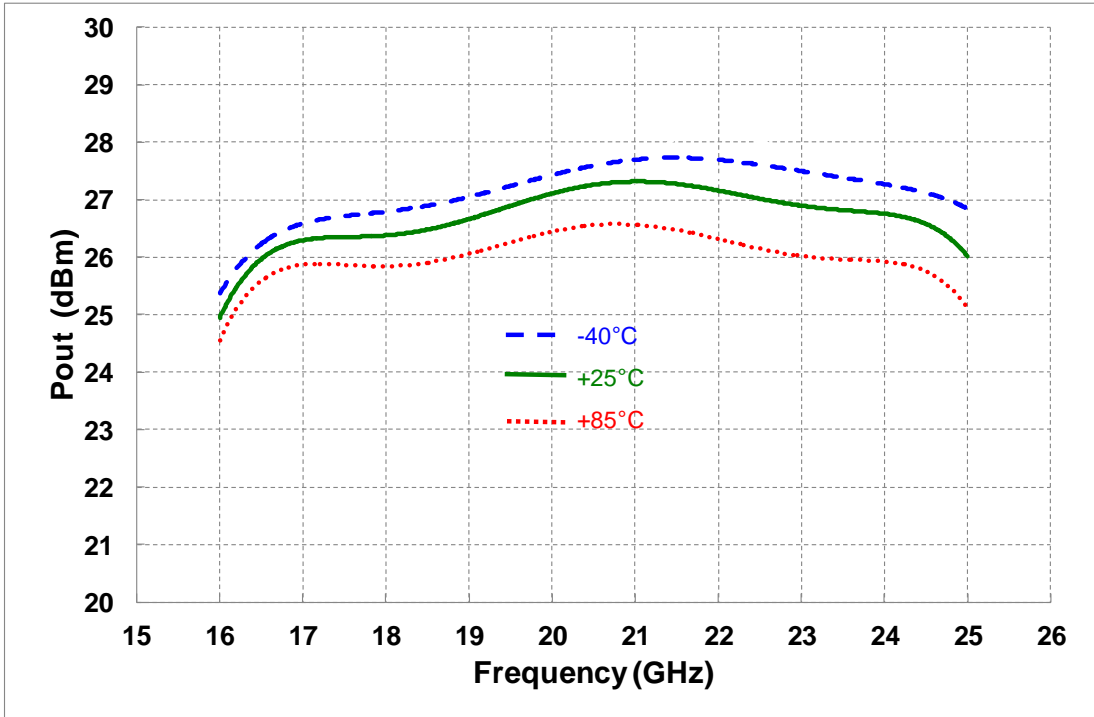

Drain Current @ 1dB Comp versus Frequency and Temperature

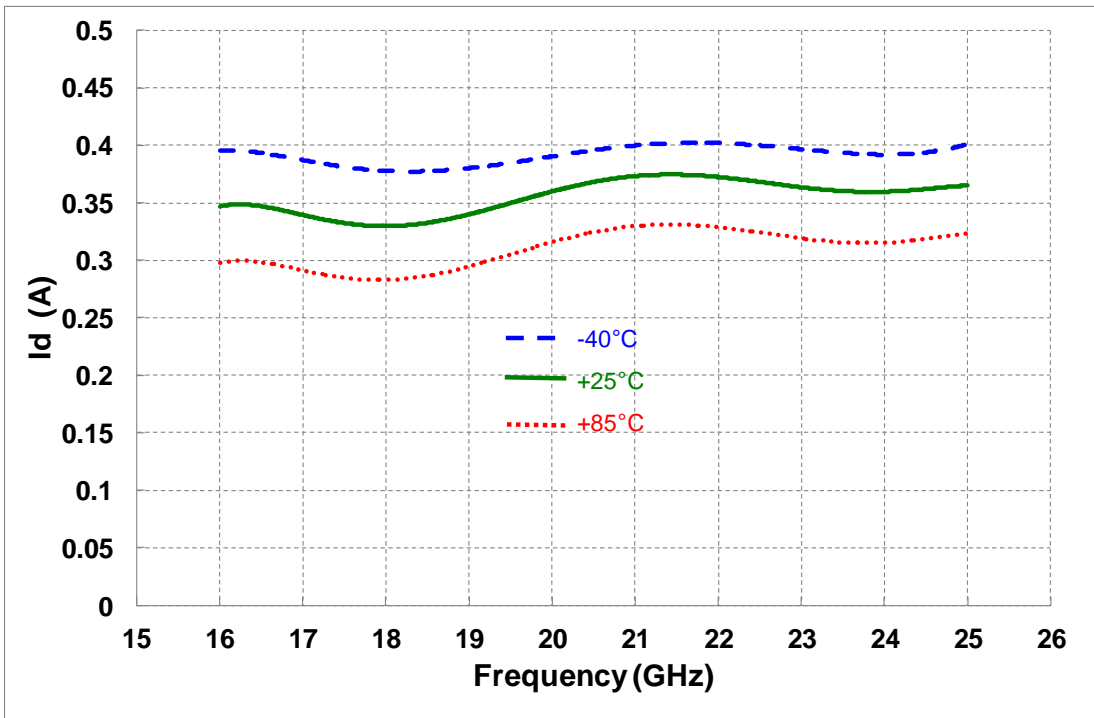

Typical Test Fixture Measurements

$V_{d1,2,3,4} = +6V$, $I_{dq} = 300mA$

Output IP3 versus Frequency and Temperature

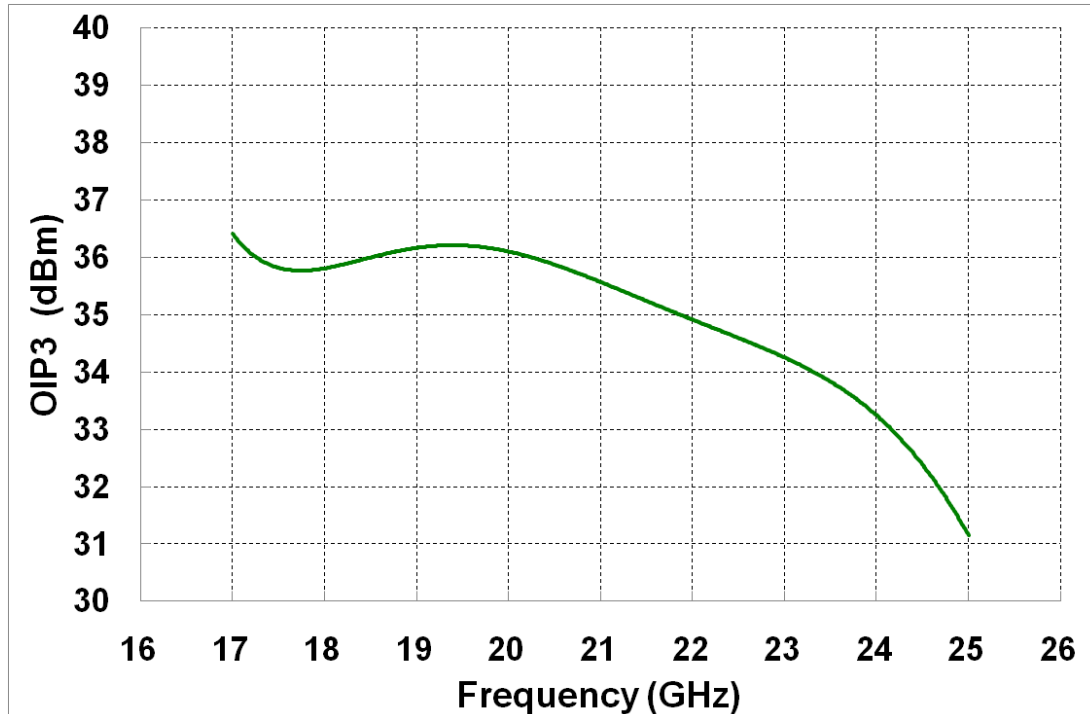

Output Power @ 1dB Comp versus Frequency and Vd

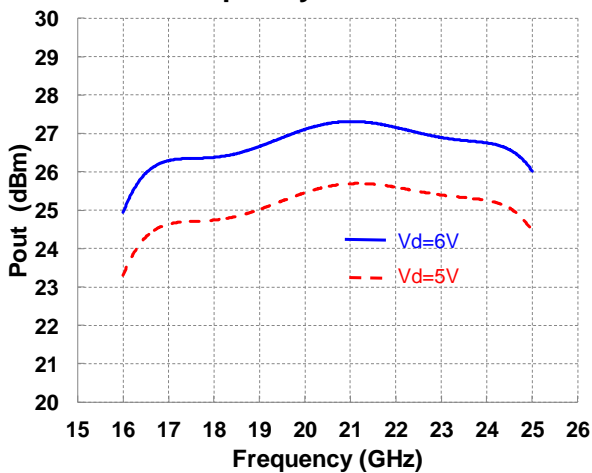

Output IP3 versus Frequency and Vd

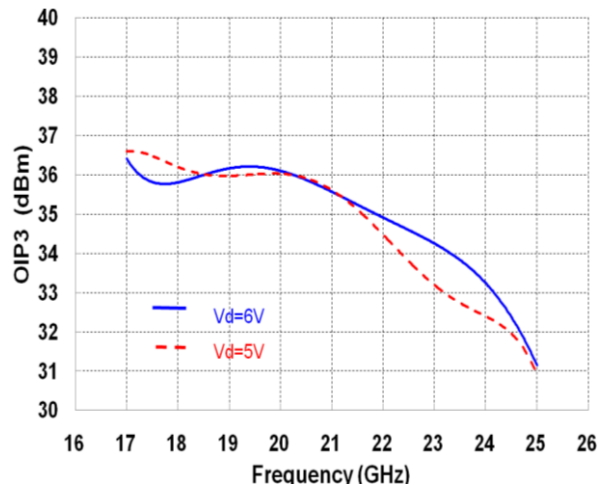

Mechanical data

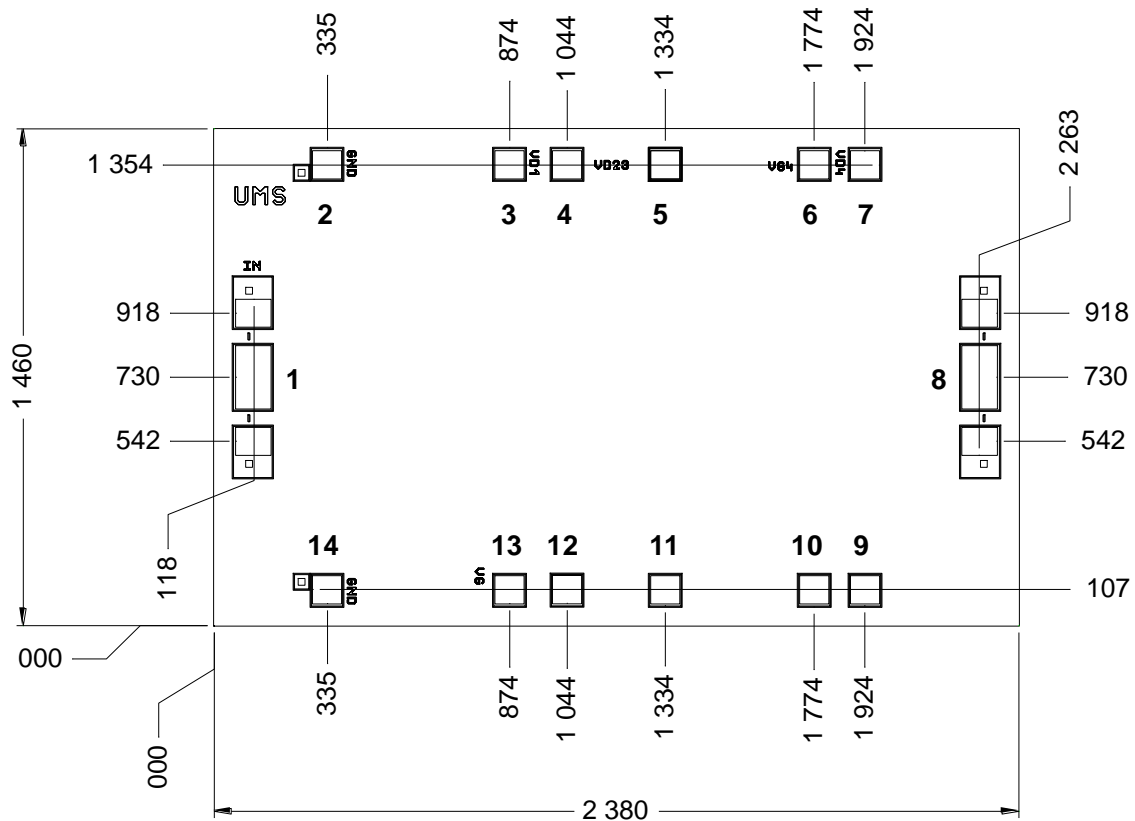

All dimensions are in micrometers

Chip size = 2380x1460 ±35μm

Chip thickness = 70μm ±10μm

RF pads (1, 8) = 110 x 200μm²

DC pads = 100 x 100μm²

Chip width and length are given with a tolerance of ±35μm

Pin number	Pin name	Description
1	IN	Input RF
2, 14	Gnd	Gnd (NC)
3	Vd1	1 st stage drain voltage
5	Vd2, Vd3	2 nd and 3 rd drain voltage
7	Vd4	4 th drain voltage
8	OUT	Output RF
10	Vg	Gate voltage
4, 6, 9, 11, 12, 13	/	NC

Recommended assembly plan

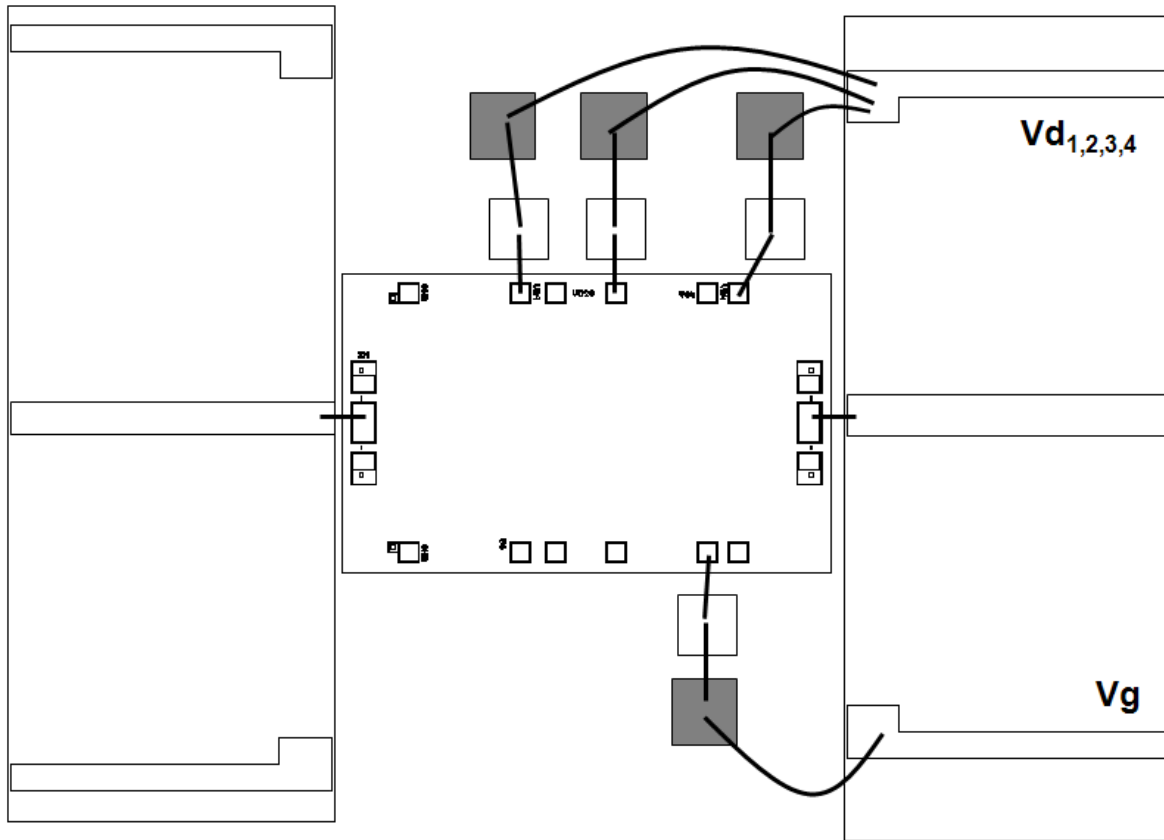

25µm wedge bonding is preferred

Note: Supply feed should be bypassed. 25µm diameter gold wire is to be preferred.

Recommended circuit bonding table

Label	Type	Decoupling	Comment
IN, OUT	RF	Not required	Inductance (Lbonding) = 0.3nH 400µm length with a wire diameter of 25 µm
Vd1, Vd2, Vd3 Vd4	Vd	120pF & 10nF	Drain Supply
Vg	Vg	120pF & 10nF	Gate Supply

DC Schematic

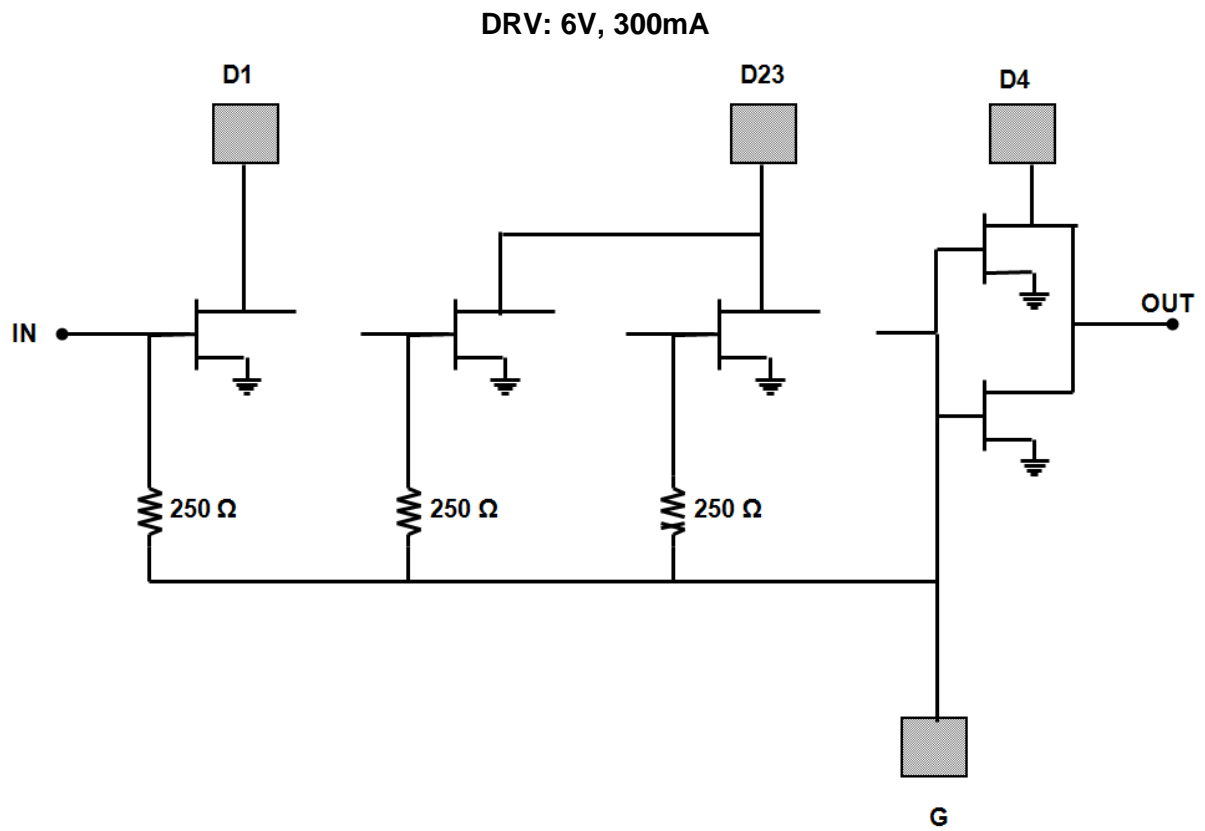

Recommended ESD management

Refer to the application note AN0020 available at <http://www.ums-gaas.com> for ESD sensitivity and handling recommendations for the UMS products.

Recommended environmental management

UMS products are compliant with the regulation in particular with the directives RoHS N°2011/65 and REACH N°1907/2006. More environmental data are available in the application note AN0019 also available at <http://www.ums-gaas.com>.

Ordering Information

Chip form:

CHA5350-99F/00

Information furnished is believed to be accurate and reliable. However **United Monolithic Semiconductors S.A.S.** assumes no responsibility for the consequences of use of such information nor for any infringement of patents or other rights of third parties which may result from its use. No license is granted by implication or otherwise under any patent or patent rights of **United Monolithic Semiconductors S.A.S.** Specifications mentioned in this publication are subject to change without notice. This publication supersedes and replaces all information previously supplied. **United Monolithic Semiconductors S.A.S.** products are not authorised for use as critical components in life support devices or systems without express written approval from **United Monolithic Semiconductors S.A.S.**