

W-Band Dual Channel Transmitter/Receiver

GaAs Monolithic Microwave IC

Description

The CHM1270a98F is a dual channel self-biased transmitter/receiver. One RF port used for reception and one for both emission and reception. This product is designed for optimum IF noise performances.

This circuit is well adapted to the sensors system at W-Band, such as automotive long range radar and industrial sensors.

This circuit is manufactured with the BES MMIC process: 1 μm very high Ft Schottky diode device, air bridges, via holes through the substrate.

It is available in chip form with BCB top layer protection.

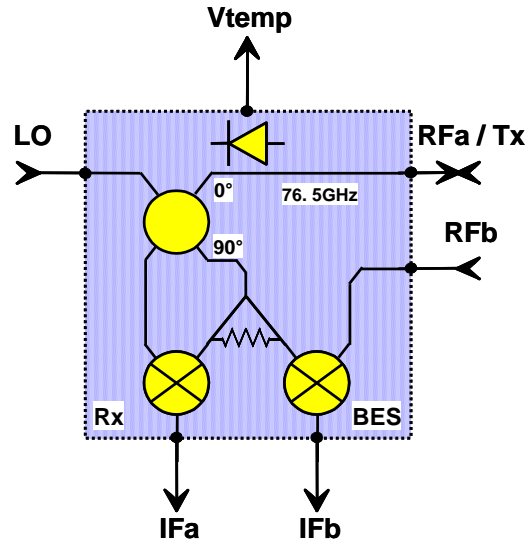

Transmitter/Receiver block diagram

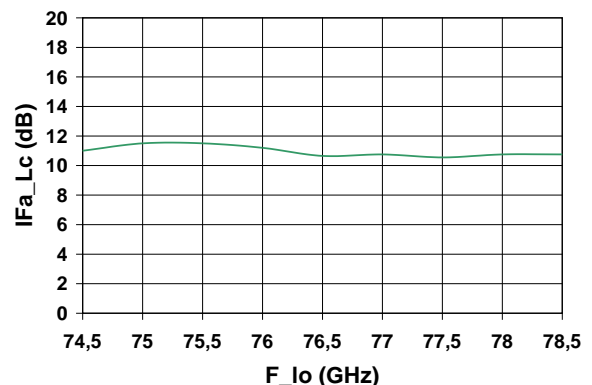

On wafer typical IFa_Lc measurement

Main Electrical Characteristics

Tamb.= +25°C

Symbol	Parameter	Min	Typ	Max	Unit
F _{LO} , F _{RF}	RF & LO Frequency range	76		77	GHz
F _{IF}	IF Frequency range	DC		100	MHz
LC _{IFa}	IFa conversion loss		11.0		dB
LC _{IFb}	IFb conversion loss		7.5		dBm
N _{IF}	IF port noise power @ IF=100kHz		-162		dBm/Hz

Electrical Characteristics

Tamb.= +25°C

Symbol	Parameter	Min	Typ	Max	Unit
F_{LO}, F_{RF}	LO and RF frequency range	76		77	GHz
F_{IF}	IF frequency range	DC		100	MHz
P_{LO}	LO input power		15		dBm
$P_{LO/RFa}$	LO output power on RFa port ⁽⁴⁾		10		dBm
LC_{IFa}	IFa conversion loss ^{(2) (4)}		11		dB
LC_{IFb}	IFb conversion loss ^{(2) (4)}		7.5		dB
$Ph_{IFx/RFx}$	IF ports phase shift difference / RF ⁽⁴⁾		90		°
$P1dB_{RFa}$	RFa ports input power at 1 dB compression		3.5		dBm
$P1dB_{RFb}$	RFb ports input power at 1 dB compression		0		dBm
$VSWR_{LO}$	LO port VSWR (50Ω) ⁽¹⁾			2.5:1	
$VSWR_{RFx}$	RFx ports VSWR (50Ω) ⁽¹⁾			2.5:1	
Z_{IFx}	IFx ports load impedance ⁽²⁾		200		Ω
$ISO_{RFa/RFb}$	Isolation between RF channels		25		dB
$RejAM_{IFa}$	LO AM noise rejection (SSB) at IFa port @ $VSWR_{RFa} < 1.3:1$		30		dB
					dB
$RejAM_{IFb}$	LO AM noise rejection (SSB) at IFb port @ $VSWR_{RFb} < 2.5:1$		30		dB
					dB
N_{IF}	IF ports noise power @IF=1kHz ⁽³⁾		-150		dBm/Hz
	IF ports noise power @IF=10kHz ⁽³⁾		-157		dBm/Hz
	IF ports noise power @IF=100kHz ⁽³⁾		-162		dBm/Hz
	IF ports noise power @IF=1MHz ⁽³⁾		-166		dBm/Hz
DC_{IF}	IF ports dc voltage	-0.3		+0.3	V
$Vtemp_V$	Vtemp port voltage @ +25°C		1.5		V
$Vtemp_I$	Vtemp port current ⁽⁵⁾		3		mA
Top	Operating temperature range	-40		+85	°C

⁽¹⁾ Parameters are given in the following conditions: (See § Recommended assembly plan):

- LO port: 50Ω reference plan before 0.15nH bonding.
- RFa & RFb ports: 50Ω reference plan after 0.15nH bonding.

⁽²⁾ Optimum IF load: 200Ω for conversion losses or 50Ω for noise figure (typically 2dB improvement).

⁽³⁾ Measured on 50Ω IF load. Mixer noise only, too high $VSWR_{RFx}$ may produce additional IF noise due to LO AM noise detection.

⁽⁴⁾ These specifications are guaranteed for $VSWR_{RFx} < 2.0:1$. Too high $VSWR_{RFa}$ produces LO phase detection that affect mixer self-bias.

⁽⁵⁾ The current $Vtemp_I$ has to be fixed by an external resistor.

Absolute Maximum Ratings ⁽¹⁾

Tamb.= +25°C

Symbol	Parameter	Values	Unit
P _{LO}	LO port input power	18	dBm
P _{RFa}	RFa ports input power	6	dBm
P _{RFb}	RFb ports input power	3	dBm
Vtemp _I	Vtemp port current	6	mA
Top	Operating temperature range	-40 to +85	°C
Tstg	Storage temperature range	-55 to +150	°C

⁽¹⁾ Operation of this device above anyone of these parameters may cause permanent damage.

⁽²⁾ Duration < 1s.

Typical Measurements with chip bonded

T_{amb}. = +25°C

IFa & IFb Conversion Losses versus LO Frequency

P_{LO} = 15dBm / Z_{IFx} = 200Ω / LO, RFa, RFb ports: 50Ω reference plan after 0.15nH bonding

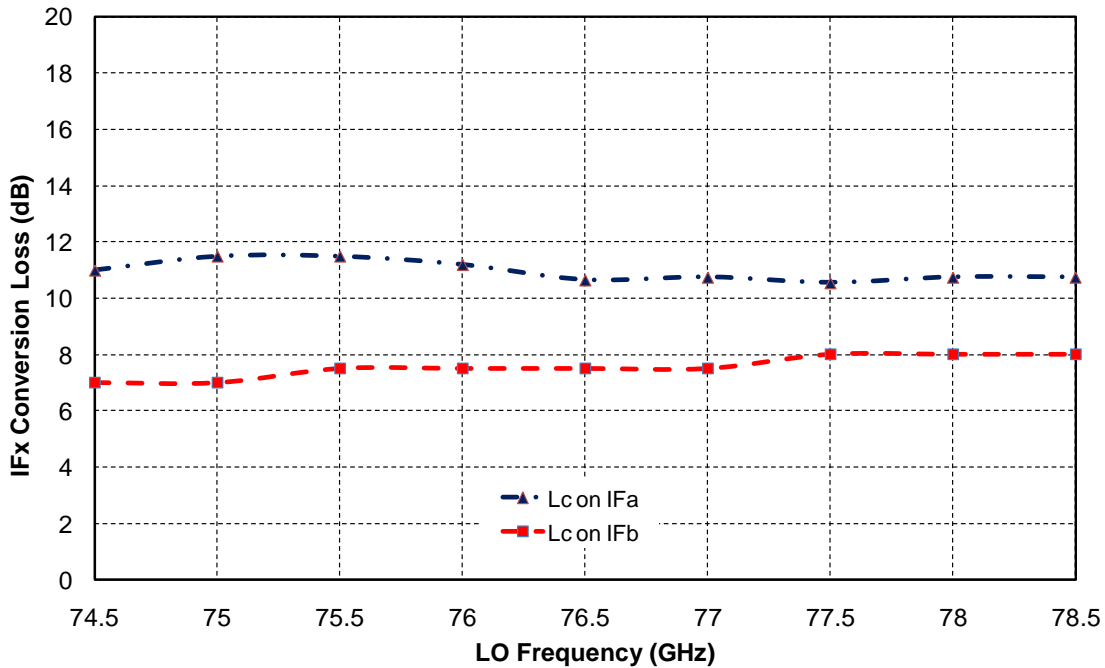

LO Output Power on RFa port versus LO Frequency

P_{LO} = 15dBm / Z_{IFx} = 200Ω / LO, RFa, RFb ports: 50Ω reference plan after 0.15nH bonding

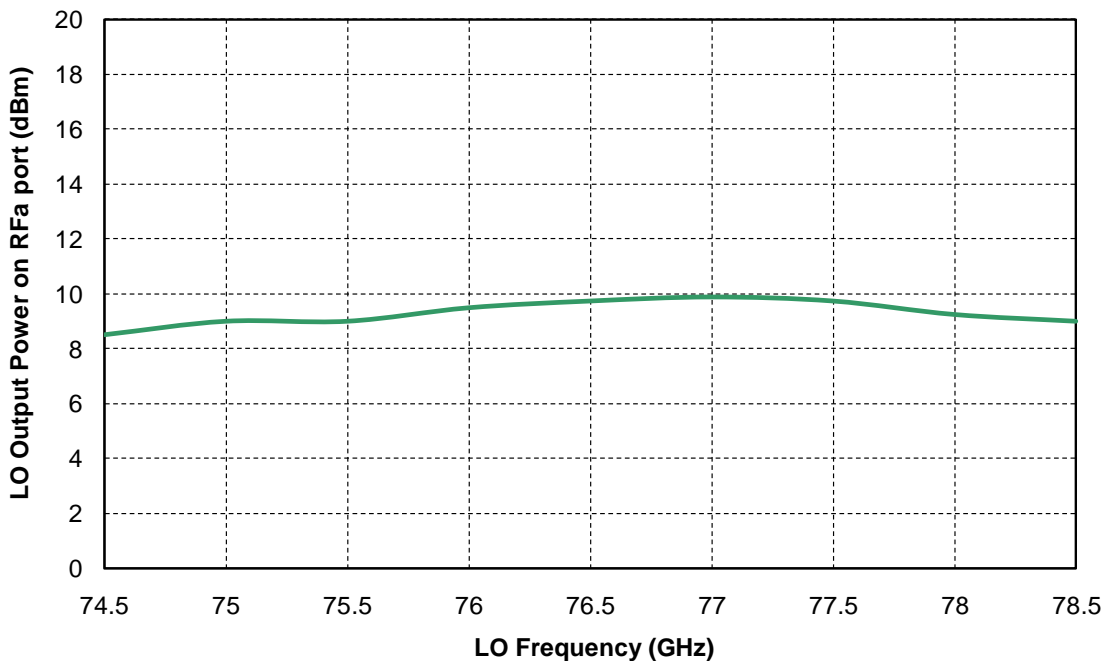

Mechanical data

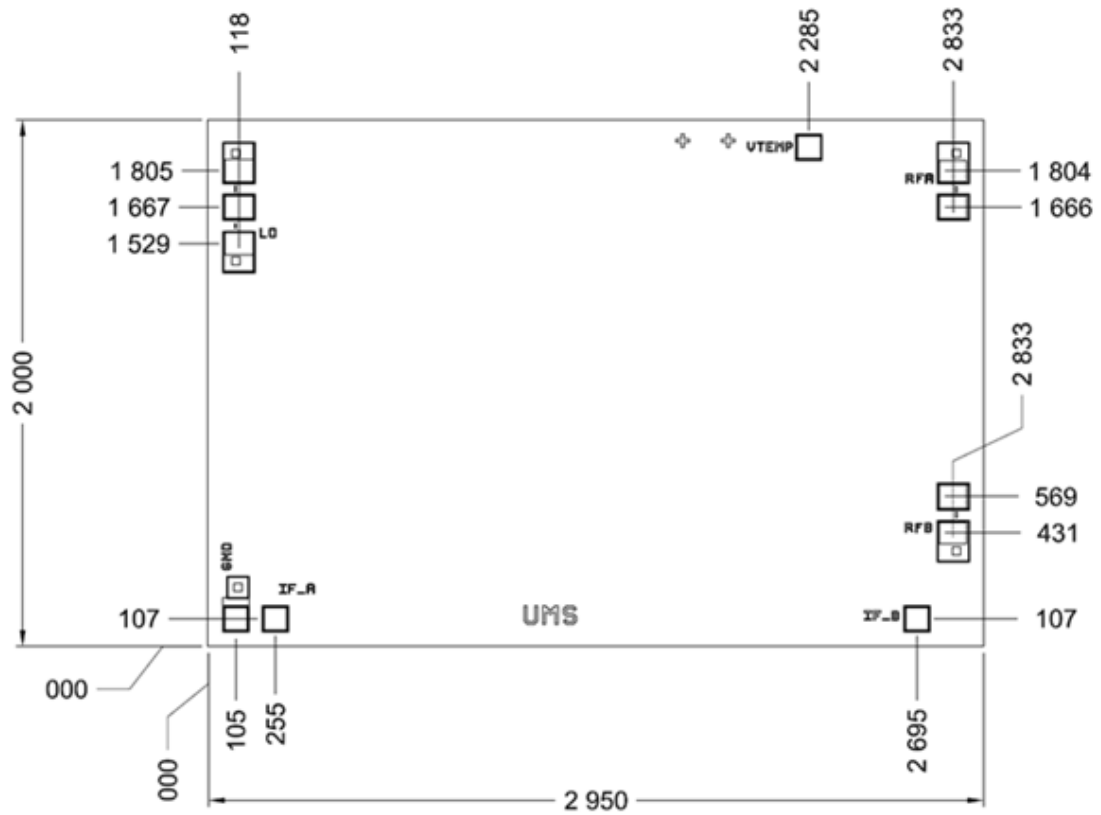

Chip thickness: 100 +/- 10
 Chip size: 2950 x 2000 ±35
 All dimensions are in micrometers

RF Pads (2, 4, 5) = 90 x 110 (BCB opening)
 IF, DC Pad (1, 6, 3) = 90 x 87 (BCB opening)

Recommended assembly plan

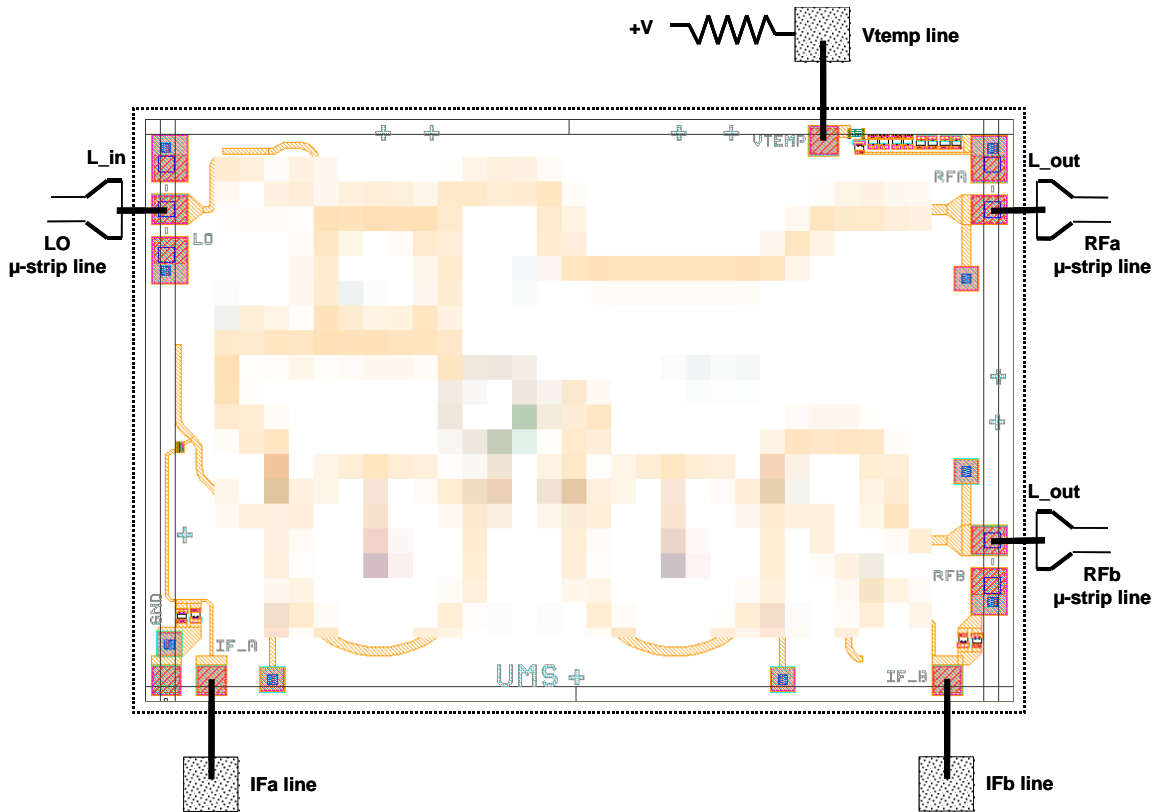

This drawing shows an example of assembly. DC power supply is required only when temperature sensor is used.

For the RF and LO pads the equivalent wire bonding inductance (diameter=25μm) has to be made according to the following recommendation to match 50 Ohms μ-strip line:

Recommended circuit bonding table

Label	Equivalent inductance	Wire length (1)	Comment
LO	$L_{in} = 0.15 \text{ nH}$	0.2 mm (2)	LO input port
RFa	$L_{out} = 0.15 \text{ nH}$	0.2 mm (2)	RFa input/output port
RFb	$L_{out} = 0.15 \text{ nH}$	0.2 mm (2)	RFb input port

(1) This value is the total length including the necessary loop from pad to μ-strip line.

(2) For longer wire length or higher inductance, an external compensation is required to match 50Ω between LO or RF Pins and 0.15nH wire inductance plan. (For example with a matching network on the substrate)

Note: Chip backside must be RF grounded.

Notes

Recommended ESD management

Refer to the application note AN0020 available at <http://www.ums-gaas.com> for ESD sensitivity and handling recommendations for the UMS products.

Recommended environmental management

UMS products are compliant with the regulation in particular with the directives RoHS N°2011/65 and REACH N°1907/2006. More environmental data are available in the application note AN0019 also available at <http://www.ums-gaas.com>.

Ordering Information

Chip form:

CHM1270a98F/00

Information furnished is believed to be accurate and reliable. However **United Monolithic Semiconductors S.A.S.** assumes no responsibility for the consequences of use of such information nor for any infringement of patents or other rights of third parties which may result from its use. No license is granted by implication or otherwise under any patent or patent rights of **United Monolithic Semiconductors S.A.S.** Specifications mentioned in this publication are subject to change without notice. This publication supersedes and replaces all information previously supplied. **United Monolithic Semiconductors S.A.S.** products are not authorised for use as critical components in life support devices or systems without express written approval from **United Monolithic Semiconductors S.A.S.**