



<i>flowPACK E2</i>	1200 V / 100 A
<div style="background-color: #eee; padding: 2px; margin-bottom: 5px;"><b>Features</b></div> <ul style="list-style-type: none"> <li>IGBT Mitsubishi gen 7 technology with low <math>V_{CEsat}</math> and improved EMC behavior</li> <li>Standard industrial package</li> <li>Built-in NTC</li> </ul>	<div style="background-color: #eee; padding: 2px; margin-bottom: 5px;"><b>flow E2 12 mm housing</b></div> <div style="display: flex; justify-content: space-around; align-items: center;"> </div> <div style="display: flex; justify-content: space-around; margin-top: 5px;"> <span>Press-fit pin</span> <span>Solder pin</span> </div>
<div style="background-color: #eee; padding: 2px; margin-bottom: 5px;"><b>Target applications</b></div> <ul style="list-style-type: none"> <li>Industrial Drives</li> <li>UPS</li> </ul>	<div style="background-color: #eee; padding: 2px; margin-bottom: 5px;"><b>Schematic</b></div>
<div style="background-color: #eee; padding: 2px; margin-bottom: 5px;"><b>Types</b></div> <ul style="list-style-type: none"> <li>10-EY126PA100M7-L198F78T</li> <li>10-E2126PA100M7-L198F78Z</li> </ul>	

## Maximum Ratings

$T_j = 25\text{ °C}$ , unless otherwise specified

Parameter	Symbol	Condition	Value	Unit
<b>Inverter Switch</b>				
Collector-emitter voltage	$V_{CES}$		1200	V
Collector current	$I_C$	$T_j = T_{jmax}$ $T_s = 80\text{ °C}$	91	A
Repetitive peak collector current	$I_{CRM}$	$t_p$ limited by $T_{jmax}$	200	A
Total power dissipation	$P_{tot}$	$T_j = T_{jmax}$ $T_s = 80\text{ °C}$	174	W
Gate-emitter voltage	$V_{GES}$		±20	V
Short circuit ratings	$t_{SC}$	$V_{GE} = 15\text{ V}$ $V_{CE} = 800\text{ V}$ $T_j = 150\text{ °C}$	9,5	µs
Maximum junction temperature	$T_{jmax}$		175	°C



## Maximum Ratings

$T_j = 25\text{ °C}$ , unless otherwise specified

Parameter	Symbol	Condition	Value	Unit
<b>Inverter Diode</b>				
Peak repetitive reverse voltage	$V_{RRM}$		1200	V
Continuous (direct) forward current	$I_F$	$T_j = T_{jmax}$ $T_s = 80\text{ °C}$	72	A
Repetitive peak forward current	$I_{FRM}$		200	A
Total power dissipation	$P_{tot}$	$T_j = T_{jmax}$ $T_s = 80\text{ °C}$	121	W
Maximum junction temperature	$T_{jmax}$		175	°C

## Module Properties

### Thermal Properties

Storage temperature	$T_{stg}$		-40...+125	°C
Operation temperature under switching condition	$T_{jop}$		-40...( $T_{jmax} - 25$ )	°C

### Isolation Properties

Isolation voltage	$V_{isol}$	DC Test Voltage* $t_p = 2\text{ s}$	6000	V
		AC Voltage $t_p = 1\text{ min}$	2500	V
Creepage distance			min. 12,7	mm
Clearance			9,08	mm
Comparative Tracking Index	CTI		≥ 600	

\*100 % tested in production



Vincotech

**10-EY126PA100M7-L198F78T**  
**10-E2126PA100M7-L198F78Z**  
 datasheet

## Characteristic Values

Parameter	Symbol	Conditions					Value			Unit
		$V_{GS}$ [V]	$V_{GE}$ [V]	$V_{DS}$ [V]	$I_D$ [A]	$T_j$ [°C]	Min	Typ	Max	

### Inverter Switch

#### Static

Parameter	Symbol	$V_{GS}$ [V]	$V_{GE}$ [V]	$V_{DS}$ [V]	$I_D$ [A]	$T_j$ [°C]	Min	Typ	Max	Unit
Gate-emitter threshold voltage	$V_{GE(th)}$				0,01	25	5,4	6	6,6	V
Collector-emitter saturation voltage	$V_{CESat}$	15			100	25 125 150		1,61 1,82 1,91	1,85	V
Collector-emitter cut-off current	$I_{CES}$	0	1200			25			100	μA
Gate-emitter leakage current	$I_{GES}$	20	0			25			500	nA
Internal gate resistance	$r_g$							0		Ω
Input capacitance	$C_{ies}$							21000		pF
Output capacitance	$C_{oes}$	0	10		25			700		
Reverse transfer capacitance	$C_{res}$							280		
Gate charge	$Q_g$	15	600	100		25		700		nC

#### Thermal

Parameter	Symbol	Value	Unit
Thermal resistance junction to sink	$R_{th(j-s)}$	$\lambda_{paste} = 3,4$ W/mK (PSX)	K/W

#### Dynamic

Parameter	Symbol	$V_{GS}$ [V]	$V_{GE}$ [V]	$V_{DS}$ [V]	$I_D$ [A]	$T_j$ [°C]	Min	Typ	Max	Unit
Turn-on delay time	$t_{d(on)}$					25 125 150		118 118 118		ns
Rise time	$t_r$					25 125 150		10 12 13		
Turn-off delay time	$t_{d(off)}$					25 125 150		174 200 206		
Fall time	$t_f$					25 125 150		83 96 107		
Turn-on energy (per pulse)*	$E_{on}$					25 125 150		3,26 4,87 5,37		mWs
Turn-off energy (per pulse)*	$E_{off}$					25 125 150		6,61 8,77 9,49		

\*  $L_s = 12$  nH



Vincotech

**10-EY126PA100M7-L198F78T**  
**10-E2126PA100M7-L198F78Z**  
 datasheet

## Characteristic Values

Parameter	Symbol	Conditions					Value			Unit
		$V_{GE}$ [V]	$V_{CE}$ [V]	$I_C$ [A]	$T_j$ [°C]	Min	Typ	Max		

### Inverter Diode

#### Static

Parameter	Symbol	$V_{GE}$ [V]	$V_{CE}$ [V]	$I_C$ [A]	$T_j$ [°C]	Min	Typ	Max	Unit
Forward voltage	$V_F$			100	25 125 150		1,82 1,96 1,97	2,1	V
Reverse leakage current	$I_R$		1200		25			40	μA

#### Thermal

Parameter	Symbol	Conditions	Value	Unit
Thermal resistance junction to sink	$R_{th(j-s)}$	$\lambda_{paste} = 3,4$ W/mK (PSX)	0,79	K/W

#### Dynamic

Parameter	Symbol	$V_{GE}$ [V]	$V_{CE}$ [V]	$I_C$ [A]	$T_j$ [°C]	Min	Typ	Max	Unit
Peak recovery current	$I_{RRM}$				25 125 150		178 166 165		A
Reverse recovery time	$t_{rr}$				25 125 150		149 312 339		ns
Recovered charge	$Q_r$				25 125 150		11,60 17,27 19,18		μC
Reverse recovered energy	$E_{rec}$				25 125 150		5,14 7,75 8,59		mWs
Peak rate of fall of recovery current	$(di_{rr}/dt)_{max}$				25 125 150		4044 2649 2147		A/μs

### Thermistor

Parameter	Symbol	Conditions	Value	Unit
Rated resistance	$R$		5	kΩ
Deviation of $R_{100}$	$\Delta_{R/R}$	$R_{100} = 493$ Ω	-5	+
Power dissipation	$P$		245	mW
Power dissipation constant			1,4	mW/K
B-value	$B_{(25/50)}$	Tol. ±2 %	3375	K
B-value	$B_{(25/100)}$	Tol. ±2 %	3437	K
Vincotech NTC Reference				K



## Inverter Switch Characteristics

**figure 1.** IGBT

Typical output characteristics

$I_C = f(V_{CE})$

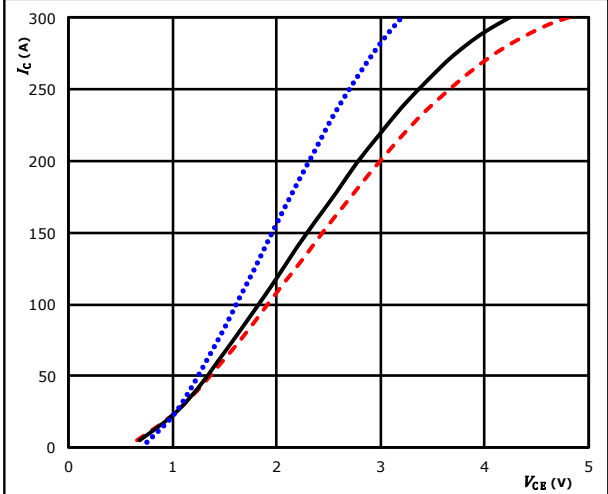

$t_p = 250 \mu s$        $T_j: 25 \text{ }^\circ C$       .....  
 $V_{GE} = 15 V$        $T_j: 125 \text{ }^\circ C$       ———  
                           $T_j: 150 \text{ }^\circ C$       - - - -

**figure 2.** IGBT

Typical output characteristics

$I_C = f(V_{CE})$

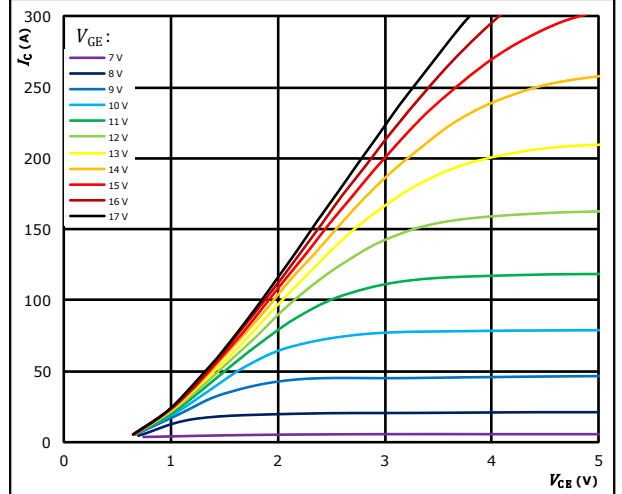

$t_p = 250 \mu s$        $T_j = 150 \text{ }^\circ C$   
 $V_{GE}$  from 7 V to 17 V in steps of 1 V

**figure 3.** IGBT

Typical transfer characteristics

$I_C = f(V_{GE})$

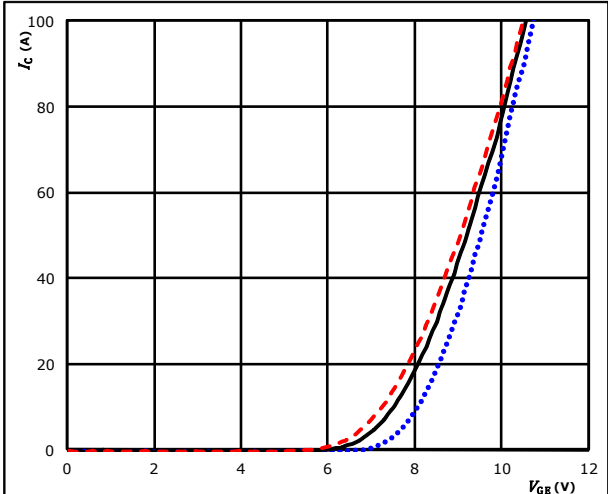

$t_p = 100 \mu s$        $T_j: 25 \text{ }^\circ C$       .....  
 $V_{CE} = 10 V$        $T_j: 125 \text{ }^\circ C$       ———  
                           $T_j: 150 \text{ }^\circ C$       - - - -

**figure 4.** IGBT

Transient thermal impedance as function of pulse duration

$Z_{th(j-s)} = f(t_p)$

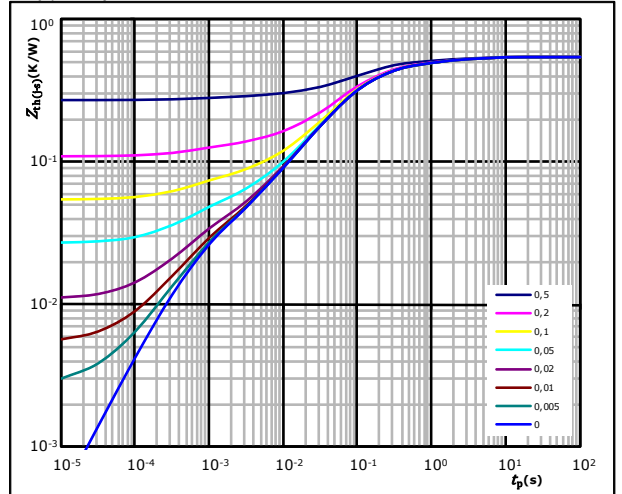

$D = t_p / T$   
 $R_{th(j-s)} = 0,55 \text{ K/W}$

IGBT thermal model values

$R$ (K/W)	$\tau$ (s)
5,00E-02	2,85E+00
9,49E-02	5,03E-01
2,74E-01	9,38E-02
8,25E-02	3,17E-02
2,20E-02	5,55E-03
2,13E-02	5,96E-04



Vincotech

**10-EY126PA100M7-L198F78T**  
**10-E2126PA100M7-L198F78Z**  
datasheet

## Inverter Switch Characteristics

**figure 5. IGBT**

Safe operating area

$$I_C = f(V_{CE})$$

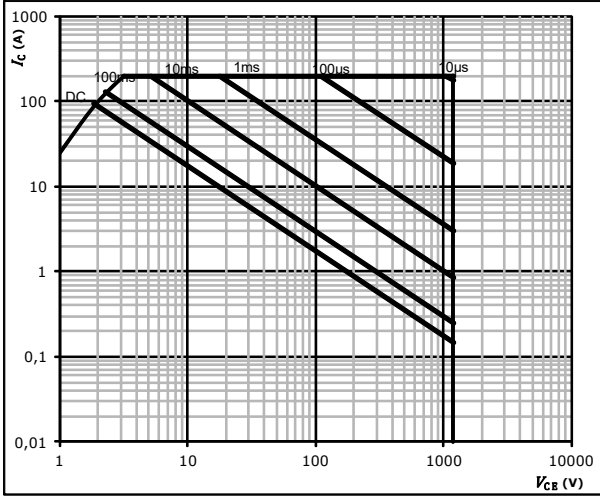

$D =$  single pulse  
 $T_s =$  80 °C  
 $V_{GE} =$  ±15 V  
 $T_j =$   $T_{jmax}$



### Inverter Diode Characteristics

**figure 1.** FWD

Typical forward characteristics

$$I_F = f(V_F)$$

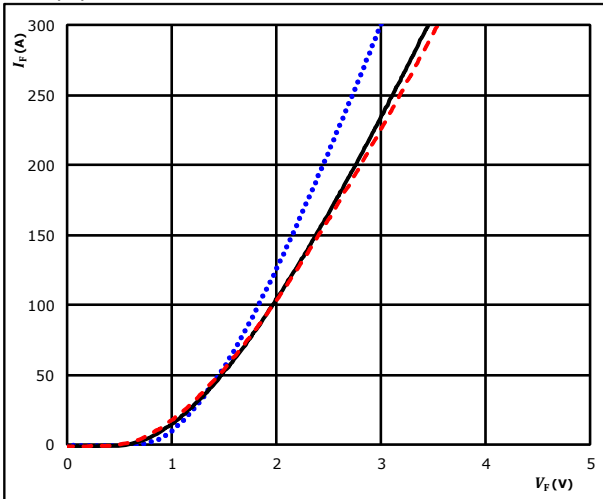

$t_p = 250 \mu s$   
 $T_j$ : 25 °C (blue dotted line)  
 125 °C (black solid line)  
 150 °C (red dashed line)

**figure 2.** FWD

Transient thermal impedance as a function of pulse width

$$Z_{th(j-s)} = f(t_p)$$

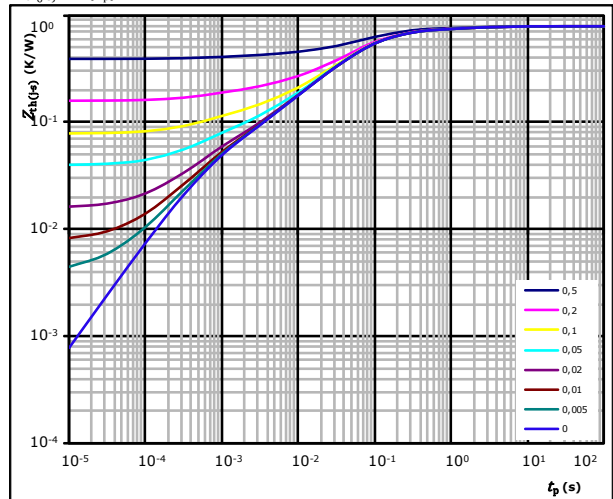

$D = t_p / T$   
 $R_{th(j-s)} = 0,79 \text{ K/W}$   
 FWD thermal model values

$R$ (K/W)	$\tau$ (s)
4,05E-02	3,25E+00
9,02E-02	5,38E-01
3,71E-01	8,95E-02
1,97E-01	3,04E-02
5,23E-02	4,59E-03
3,58E-02	6,26E-04

### Thermistor Characteristics

**figure 1.** Thermistor

Typical NTC characteristic as a function of temperature

$$R = f(T)$$

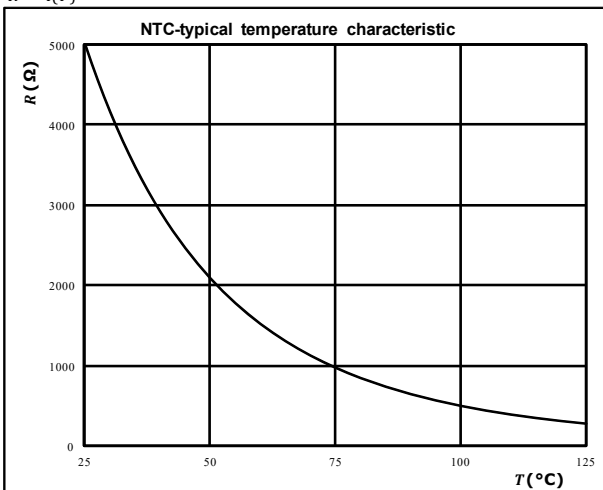



## Inverter Switching Characteristics

**figure 1.** IGBT

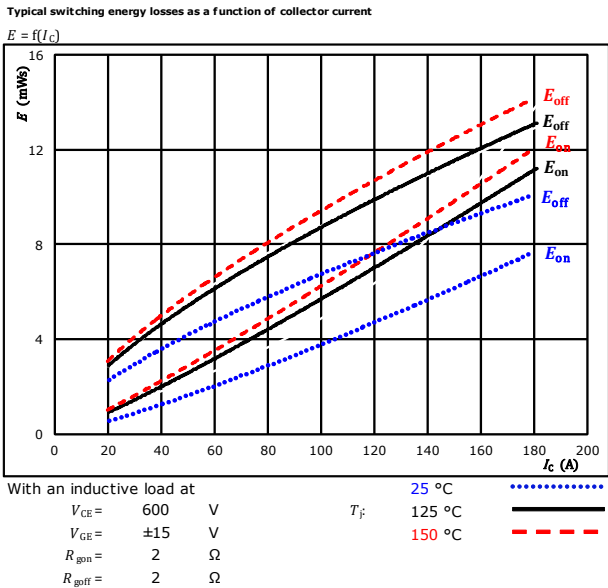

**figure 2.** IGBT

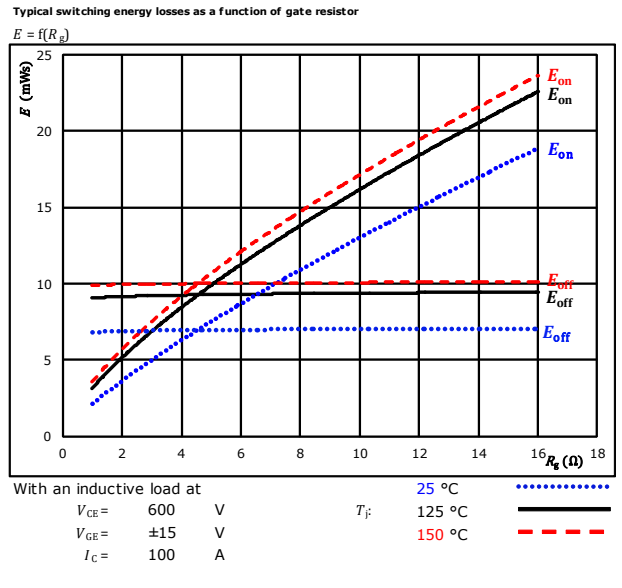

**figure 3.** FWD

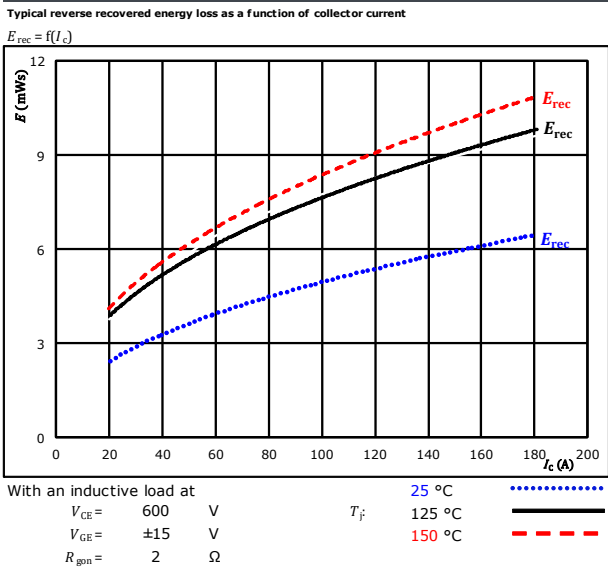

**figure 4.** FWD

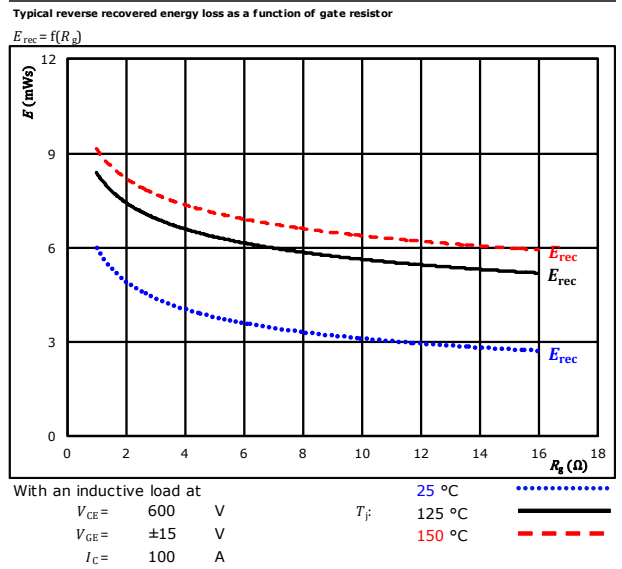





## Inverter Switching Characteristics

**figure 5.** IGBT

Typical switching times as a function of collector current

$$t = f(I_C)$$

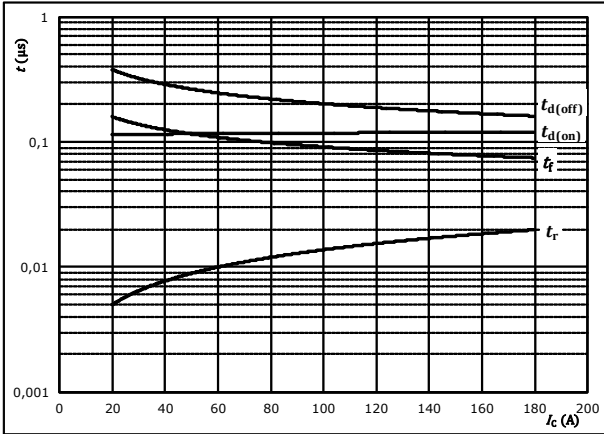

With an inductive load at

$T_j =$	150	°C
$V_{CE} =$	600	V
$V_{GE} =$	±15	V
$R_{g(on)} =$	2	Ω
$R_{g(off)} =$	2	Ω

**figure 6.** IGBT

Typical switching times as a function of gate resistor

$$t = f(R_g)$$

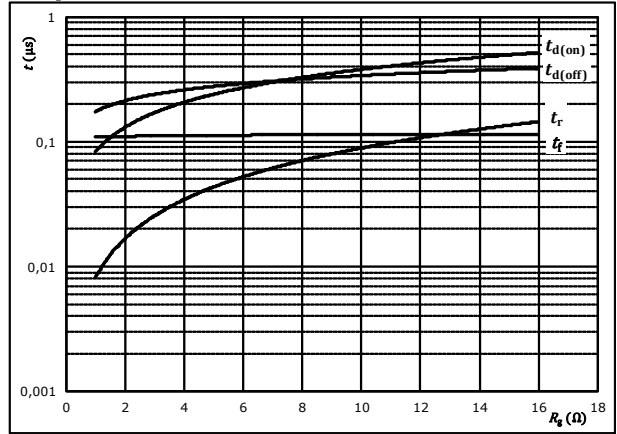

With an inductive load at

$T_j =$	150	°C
$V_{CE} =$	600	V
$V_{GE} =$	±15	V
$I_C =$	100	A

**figure 7.** FWD

Typical reverse recovery time as a function of collector current

$$t_{rr} = f(I_C)$$

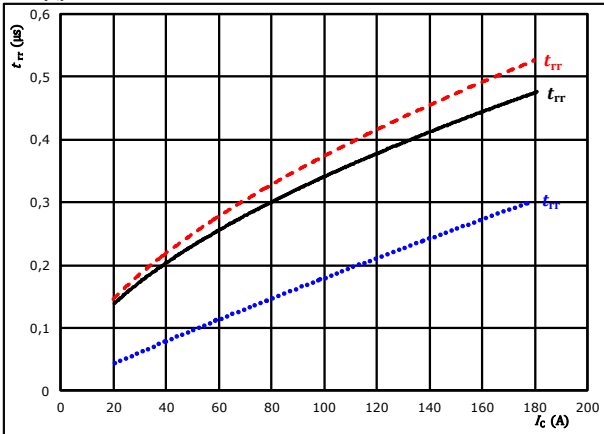

At	$V_{CE} =$	600	V	$T_j:$	25 °C	.....
	$V_{GE} =$	±15	V		125 °C	————
	$R_{g(on)} =$	2	Ω		150 °C	- - - -

**figure 8.** FWD

Typical reverse recovery time as a function of IGBT turn on gate resistor

$$t_{rr} = f(R_{g(on)})$$

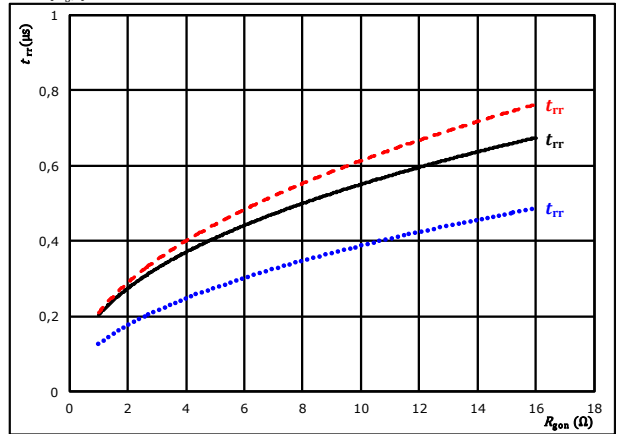

At	$V_{CE} =$	600	V	$T_j:$	25 °C	.....
	$V_{GE} =$	±15	V		125 °C	————
	$I_C =$	100	A		150 °C	- - - -



## Inverter Switching Characteristics

**figure 9.** FWD

Typical recovered charge as a function of collector current

$$Q_r = f(I_c)$$

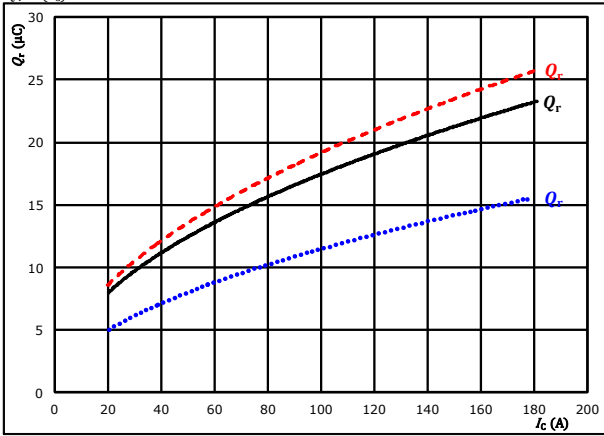

At  $V_{CE} = 600$  V  $T_j = 25$  °C  $R_{gpn} = 2$  Ω  $I_c = 100$  A  
 $V_{GE} = \pm 15$  V  $T_j = 125$  °C  
 $R_{gpn} = 2$  Ω  $T_j = 150$  °C

**figure 10.** FWD

Typical recovered charge as a function of IGBT turn on gate resistor

$$Q_r = f(R_{gpn})$$

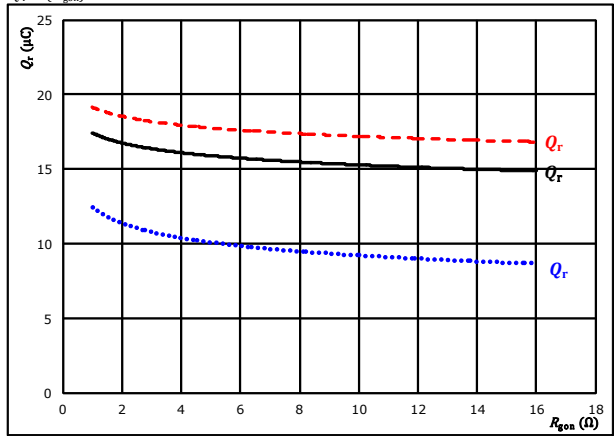

At  $V_{CE} = 600$  V  $T_j = 25$  °C  $R_{gpn} = 2$  Ω  $I_c = 100$  A  
 $V_{GE} = \pm 15$  V  $T_j = 125$  °C  
 $I_c = 100$  A  $T_j = 150$  °C

**figure 11.** FWD

Typical peak reverse recovery current current as a function of collector current

$$I_{RM} = f(I_c)$$

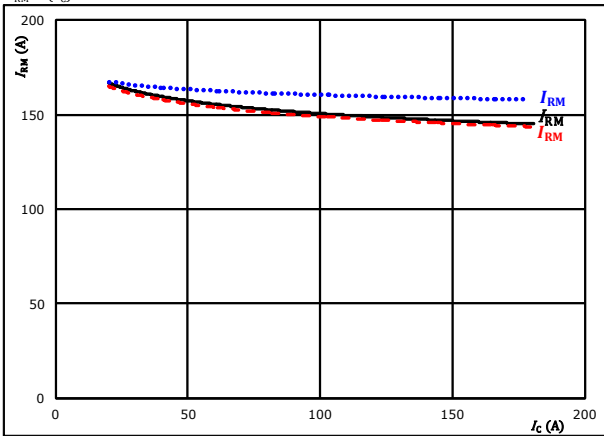

At  $V_{CE} = 600$  V  $T_j = 25$  °C  $R_{gpn} = 2$  Ω  $I_c = 100$  A  
 $V_{GE} = \pm 15$  V  $T_j = 125$  °C  
 $R_{gpn} = 2$  Ω  $T_j = 150$  °C

**figure 12.** FWD

Typical peak reverse recovery current as a function of IGBT turn on gate resistor

$$I_{RM} = f(R_{gpn})$$

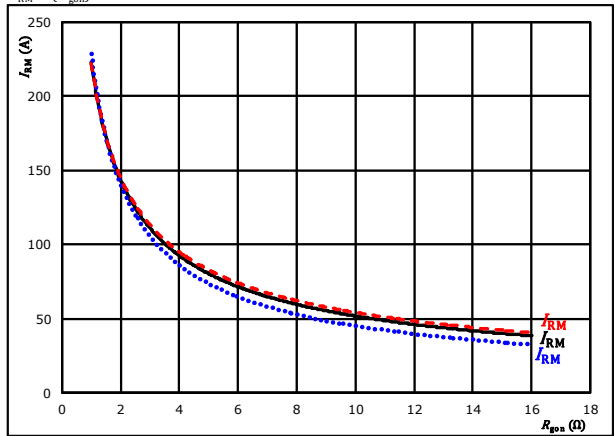

At  $V_{CE} = 600$  V  $T_j = 25$  °C  $R_{gpn} = 2$  Ω  $I_c = 100$  A  
 $V_{GE} = \pm 15$  V  $T_j = 125$  °C  
 $I_c = 100$  A  $T_j = 150$  °C



## Inverter Switching Characteristics

**figure 13.** FWD

Typical rate of fall of forward and reverse recovery current as a function of collector current  
 $di_{F}/dt, di_{rr}/dt = f(I_C)$

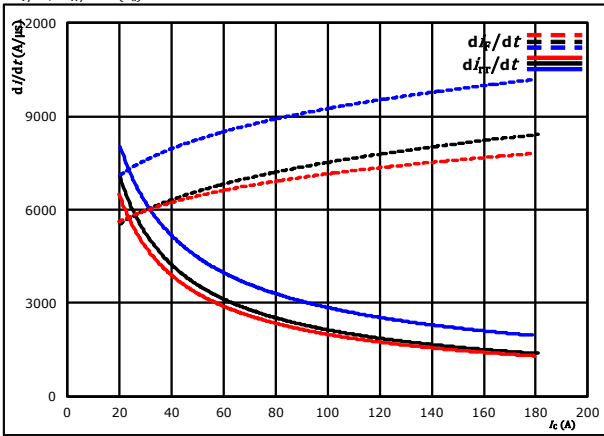

At  $V_{CE} = 600$  V  $T_j = 25$  °C  
 $V_{GE} = \pm 15$  V  $T_j = 125$  °C  
 $R_{gon} = 2$  Ω  $T_j = 150$  °C

**figure 14.** FWD

Typical rate of fall of forward and reverse recovery current as a function of IGBT turn on gate resistor  
 $di_{F}/dt, di_{rr}/dt = f(R_{gon})$

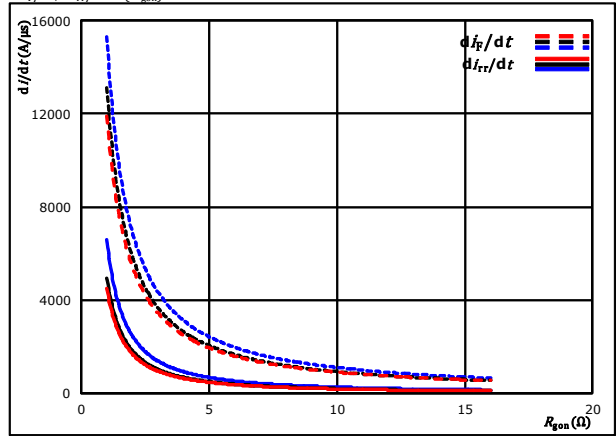

At  $V_{CE} = 600$  V  $T_j = 25$  °C  
 $V_{GE} = \pm 15$  V  $T_j = 125$  °C  
 $I_C = 100$  A  $T_j = 150$  °C

**figure 15.** IGBT

Reverse bias safe operating area  
 $I_C = f(V_{CB})$

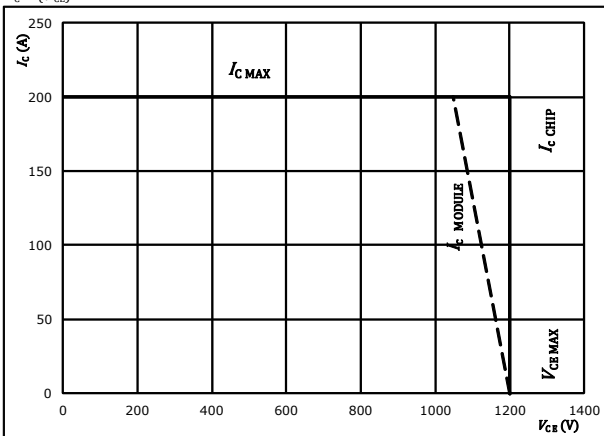

At  $T_j = 125$  °C  
 $R_{gon} = 2$  Ω  
 $R_{goff} = 2$  Ω



## Inverter Switching Definitions

**General conditions**

$T_j$	=	125 °C
$R_{gon}$	=	2 $\Omega$
$R_{goff}$	=	2 $\Omega$

**figure 1.** IGBT

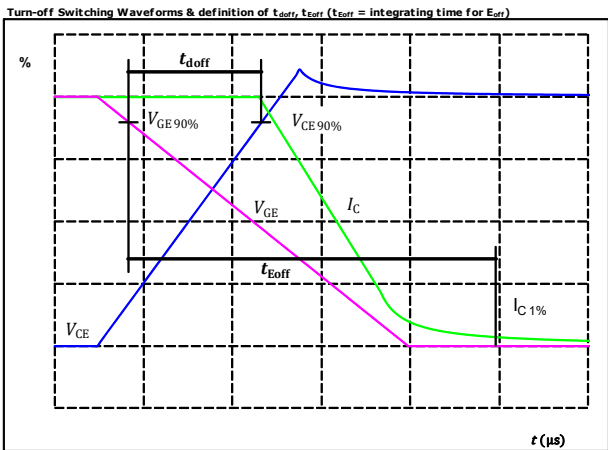

$V_{CE}(0\%) =$	-15	V
$V_{GE}(100\%) =$	15	V
$V_C(100\%) =$	600	V
$I_C(100\%) =$	100	A
$t_{doff} =$	200	ns

**figure 2.** IGBT

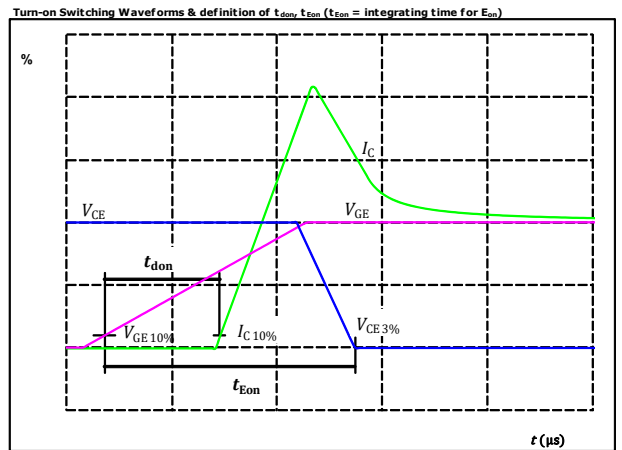

$V_{CE}(0\%) =$	-15	V
$V_{GE}(100\%) =$	15	V
$V_C(100\%) =$	600	V
$I_C(100\%) =$	100	A
$t_{don} =$	118	ns

**figure 3.** IGBT

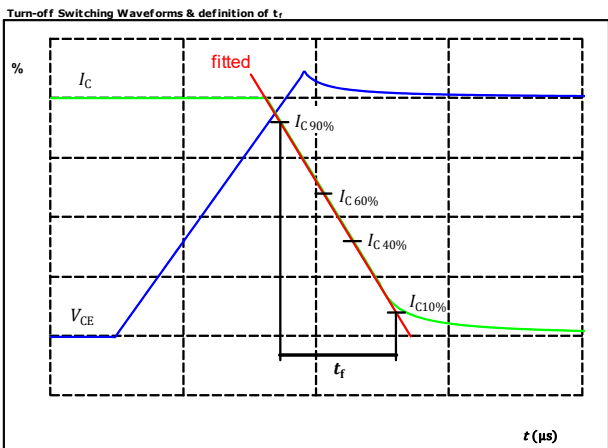

$V_C(100\%) =$	600	V
$I_C(100\%) =$	100	A
$t_f =$	96	ns

**figure 4.** IGBT

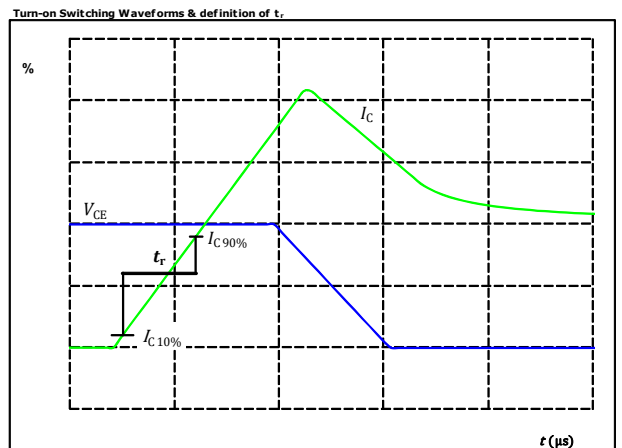

$V_C(100\%) =$	600	V
$I_C(100\%) =$	100	A
$t_r =$	12	ns



## Inverter Switching Characteristics

**figure 5.** FWD

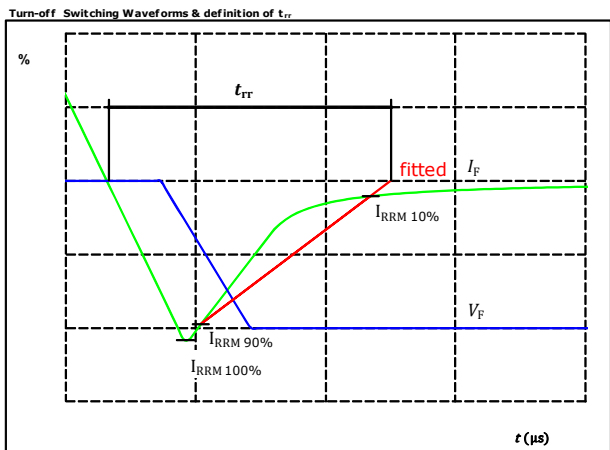

$V_F(100\%) =$	600	V
$I_F(100\%) =$	100	A
$I_{RRM}(100\%) =$	166	A
$t_{rr} =$	312	ns

**figure 6.** FWD

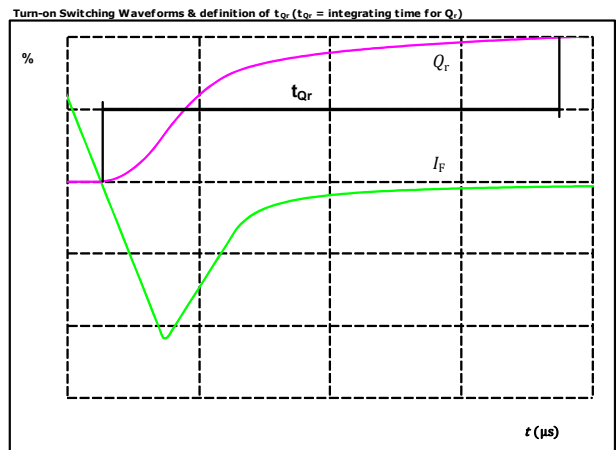

$I_F(100\%) =$	100	A
$Q_r(100\%) =$	17,27	$\mu\text{C}$



Ordering Code & Marking								
Version			Ordering Code					
without thermal paste 12 mm housing with Press-fit pins			10-EY126PA100M7-L198F78T					
with thermal paste 12 mm housing with Press-fit pins			10-EY126PA100M7-L198F78T-/3/					
without thermal paste 12 mm housing with solder pins			10-E2126PA100M7-L198F78Z					
with thermal paste 12 mm housing with solder pins			10-E2126PA100M7-L198F78Z-/3/					
NN-NNNNNNNNNNNN TTTTWWWWYY UL VIN LLLL SSSS			<b>Text</b>	<b>Name</b>	<b>Date code</b>	<b>UL &amp; VIN</b>	<b>Lot</b>	<b>Serial</b>
				NN-NNNNNNNNNNNN-TTTTWW	WWYY	UL VIN	LLLL	SSSS
			<b>Datamatrix</b>	<b>Type&amp;Ver</b>	<b>Lot number</b>	<b>Serial</b>	<b>Date code</b>	
				TTTTTWW	LLLL	SSSS	WWYY	

Pin table			
Pin	X	Y	Function
1	32	3,2	G16
2	32	0	Ph3
3	28,8	0	Ph3
4	25,6	0	Ph3
5	19,2	0	Ph2
6	16	0	Ph2
7	12,8	0	Ph2
8	12,8	3,2	G14
9	6,4	0	Ph1
10	3,2	0	Ph1
11	0	0	Ph1
12	0	3,2	G12
13	0	19,2	Therm1
14	0	28,8	Therm2
15	0	44,8	G11
16	0	48	DC-1
17	3,2	48	DC-1
18	6,4	48	DC-1
19	9,6	48	DC-1
20	12,8	48	DC-2
21	12,8	44,8	G13
22	16	48	DC-2
23	19,2	48	DC-2
24	22,4	48	DC-2
25	22,4	44,8	G15
26	25,6	48	DC-3
27	28,8	48	DC-3
28	32	48	DC-3
29	32	44,8	DC-3
30	12,8	25,6	DC+
31	12,8	22,4	DC+
32	12,8	19,2	DC+
33	12,8	16	DC+

**Outline**

center of press-fit pinhead  
for connection parameter see the handling instruction

Press-fit pin

Solder pin

0.64 ±0.03

1308 ±0.1

16.4 ±0.5

15.9 ±0.1

16

Tolerance of pinpositions: ±0.4mm at the end of pins  
Dimension of coordinate axis is only offset without tolerance



Vincotech

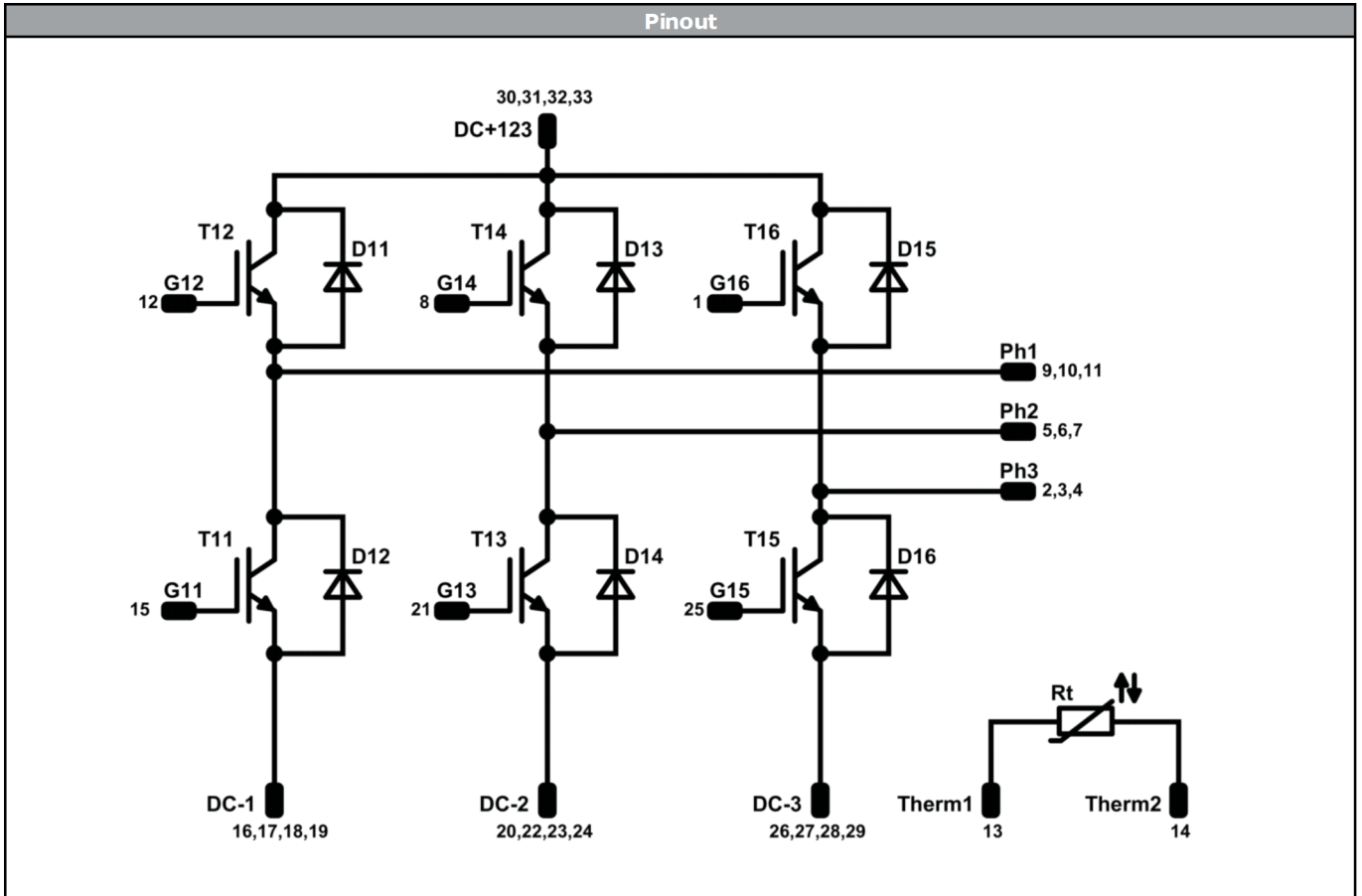

<b>Identification</b>					
<b>ID</b>	<b>Component</b>	<b>Voltage</b>	<b>Current</b>	<b>Function</b>	<b>Comment</b>
T11, T12, T13, T14, T15, T16	IGBT	1200 V	100 A	Inverter Switch	
D11, D12, D13, D14, D15, D16	FWD	1200 V	100 A	Inverter Diode	
Rt	NTC			Thermistor	



Packaging instruction			
Standard packaging quantity (SPQ) 100	>SPQ	Standard	<SPQ Sample

Handling instruction
Handling instructions for <i>flow</i> E2 packages see vincotech.com website.

Package data
Package data for <i>flow</i> E2 packages see vincotech.com website.

UL recognition and file number
This device is certified according to UL 1557 standard, UL file number E192116. For more information see vincotech.com website. 

Document No.:	Date:	Modification:	Pages
10-Ex126PA100M7-L198F78x-D5-14	27 May. 2019	Outline updated	14

**DISCLAIMER**

The information, specifications, procedures, methods and recommendations herein (together "information") are presented by Vincotech to reader in good faith, are believed to be accurate and reliable, but may well be incomplete and/or not applicable to all conditions or situations that may exist or occur. Vincotech reserves the right to make any changes without further notice to any products to improve reliability, function or design. No representation, guarantee or warranty is made to reader as to the accuracy, reliability or completeness of said information or that the application or use of any of the same will avoid hazards, accidents, losses, damages or injury of any kind to persons or property or that the same will not infringe third parties rights or give desired results. It is reader's sole responsibility to test and determine the suitability of the information and the product for reader's intended use.

**LIFE SUPPORT POLICY**

Vincotech products are not authorised for use as critical components in life support devices or systems without the express written approval of Vincotech.

As used herein:

1. Life support devices or systems are devices or systems which, (a) are intended for surgical implant into the body, or (b) support or sustain life, or (c) whose failure to perform when properly used in accordance with instructions for use provided in labelling can be reasonably expected to result in significant injury to the user.
2. A critical component is any component of a life support device or system whose failure to perform can be reasonably expected to cause the failure of the life support device or system, or to affect its safety or effectiveness.