

Product Description

Qorvo's TGS2352-2 is a single-pole, double-throw (SPDT) reflective switch fabricated on Qorvo's QGaN25 0.25um GaN on SiC production process.

Operating from 0.5 to 12 GHz, the TGS2352-2 typically provides up to 20W input power handling at control voltages of 0/-40 V. This switch maintains low insertion loss of 1 dB or less, and high isolation of 35 dB typical.

The TGS2352-2 performance allows it to be used in a variety of applications across commercial and military markets, low and high power.



Product Features

- Frequency Range: 0.5 - 12 GHz
- Power Handling: up to 20 W
- Insertion Loss: < 1 dB
- Isolation: 35 dB typical
- Control Voltages: 0 V/-40 V (from either side of the MMIC)
- Switching Speed: < 35 ns
- Die Dimensions: 1.11 mm x 1.61 mm x 0.10 mm

Performance is typical across frequency. Please reference electrical specification table and data plots for more details.

Block Diagram

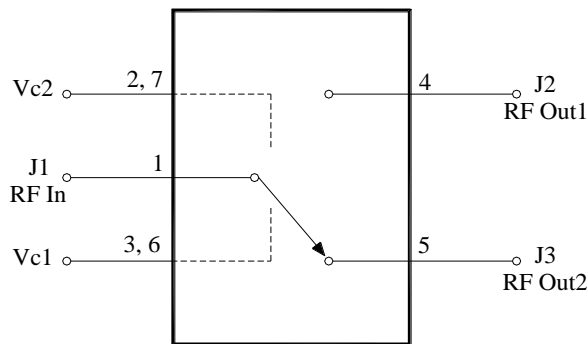

Applications

- Commercial and Military Radar
- Communications
- Electronic Warfare
- Test Instruments
- General Purpose

Ordering Information

Part No.	Description
TGS2352-2	0.5 - 12 GHz High Power Switch
TGS2352-2 EVB	Evaluation Board

Absolute Maximum Ratings

Parameter	Value
Control Voltage (V_C)	-50 V
Control Current (I_C)	-1.5 to 6.0 mA
Power Dissipation, (P_{DISS}), CW	5 W
RF Input Power, CW, 50 Ω , T = 25°C	44 dBm
Mounting Temperature (30 sec)	320 °C
Storage Temperature	-55 to 150 °C

Operation of this device outside the parameter ranges given above may cause permanent damage. These are stress ratings only, and functional operation of the device at these conditions is not implied.

Recommended Operating Conditions

Parameter	Min	Typ.	Max	Units
Frequency	0.5		12	GHz
Input Power Handling (CW)		43		dBm
Control Voltage		-40		V
Temperature Range	-40	25	+85	°C

Electrical specifications are measured at specified test conditions. Specifications are not guaranteed over all recommended operating conditions.

Electrical Specifications

Test conditions unless otherwise noted: $T_{BASE} = 25$ °C, $V_{C1} = -40/0$ V, $V_{C2} = 0/-40$ V, CW Input Power, see Function Table on page 4

Parameter	Conditions	Min	Typical	Max	Units
Operational Frequency Range		0.5		12	GHz
Insertion Loss	On-State		< 1		dB
Input Return Loss – Common Port RL	On-State		15		dB
Output Return Loss – Switched Port RL	On-State		15		dB
Isolation	Off-State		35		dB
Output Return Loss – Isolated Port RL	Off-State		3		dB
Input Power			43		dBm
Switching Speed	ON		31		nS
Switching Speed	OFF		18		nS
Insertion Loss Temperature Coefficient			0.003		dB/ °C

Thermal and Reliability Information

Parameter	Test Conditions	Value	Units
Thermal Resistance (θ_{JC}) ^(1,2)	$T_{BASE} = 85^\circ\text{C}$, $V_{C1} = 0$ V, $V_{C2} = -40$ V, Freq. = 4 GHz	22.32	°C/W
Channel Temperature (T_{CH}) ^(1,2)	$P_{IN} = 20$ W, $P_{DISS} = 4.3$ W	181	°C

- MMIC soldered to 40 mil thick Cu-Mo carrier plate using AuSn solder. Thermal resistance is determined from the channel to the back of the carrier plate (fixed 85 °C temp.).
- Refer to the following document: [GaN Device Channel Temperature, Thermal Resistance, and Reliability Estimates](#)

Performance Plots – Small Signal

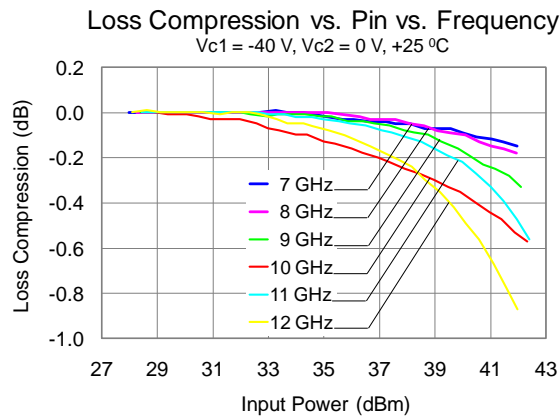
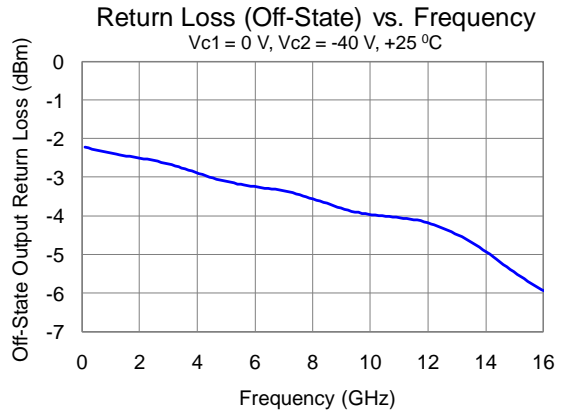
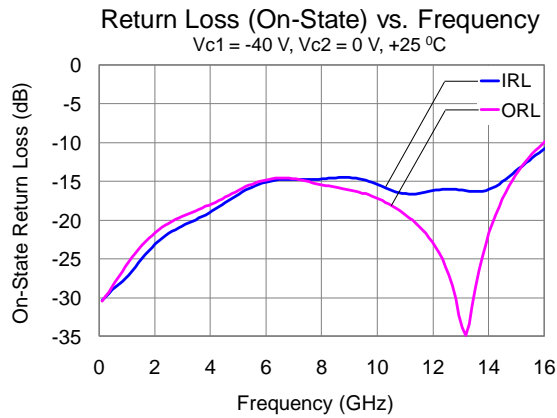
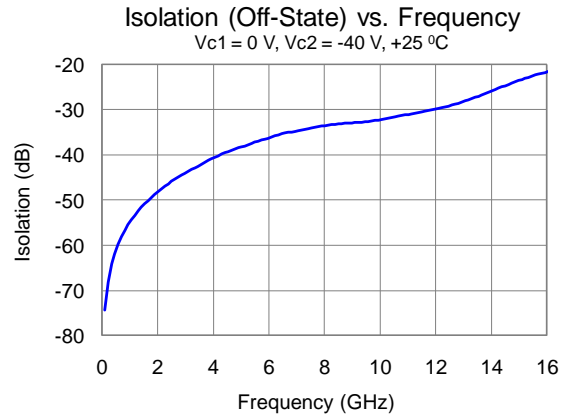
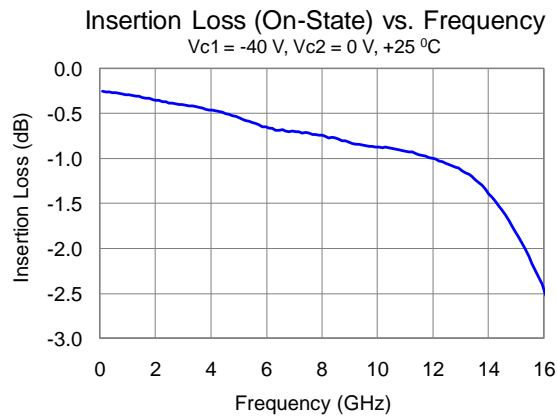

Applications Circuit

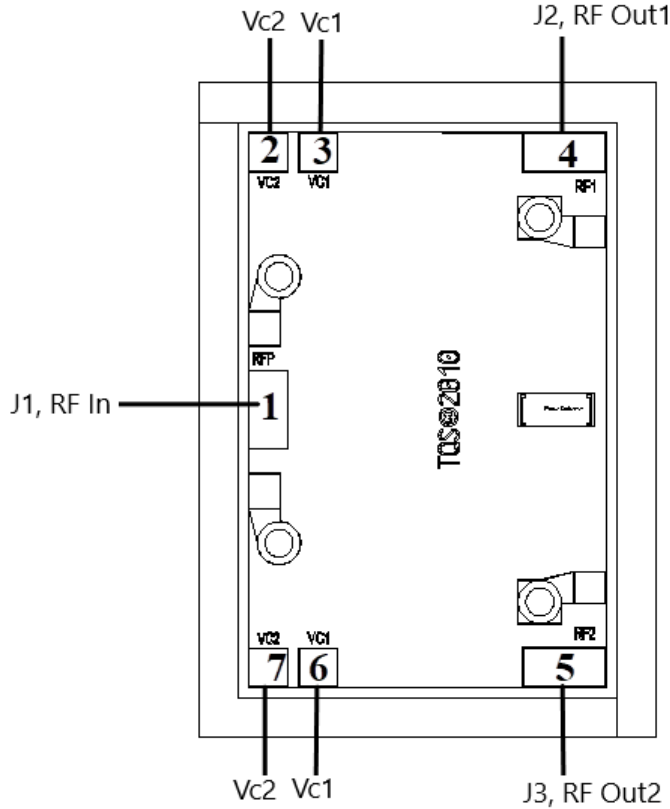

Notes:

V_{C1} can be biased from either bond pad 3 or 6, and the non-biased bond pad can be left open.
 V_{C2} can be biased from either bond pad 2 or 7, and the non-biased bond pad can be left open.

This switch can be configured as a Single Pole, Single Throw (SPST) by terminating one unused RF switched port with a 50 Ohm load.

Bias Up Procedure

1. V_{C1} or V_{C2} set to 0 V (see Function Table for RF Path)
2. V_{C2} or V_{C1} set to -40 V (see Function Table for RF Path)
3. Apply RF signal to RF Input

Bias Up Down

1. Turn off RF supply
2. Turn V_{C2} or V_{C1} to 0 V
3. Turn V_{C1} or V_{C2} to 0 V

Function Table

RF Path	State	V_{C1}	V_{C2}
RF In to RF Out1 (50 Ω load to RF Out2)	On-State (Insertion Loss)	0 V	-40 V
	Off-State (Isolation)	-40 V	0 V
RF In to RF Out2 (50 Ω load to RF Out1)	On-State (Insertion Loss)	-40 V	0 V
	Off-State (Isolation)	0 V	-40 V

Evaluation Board (EVB) Layout Assembly & Mounting Detail

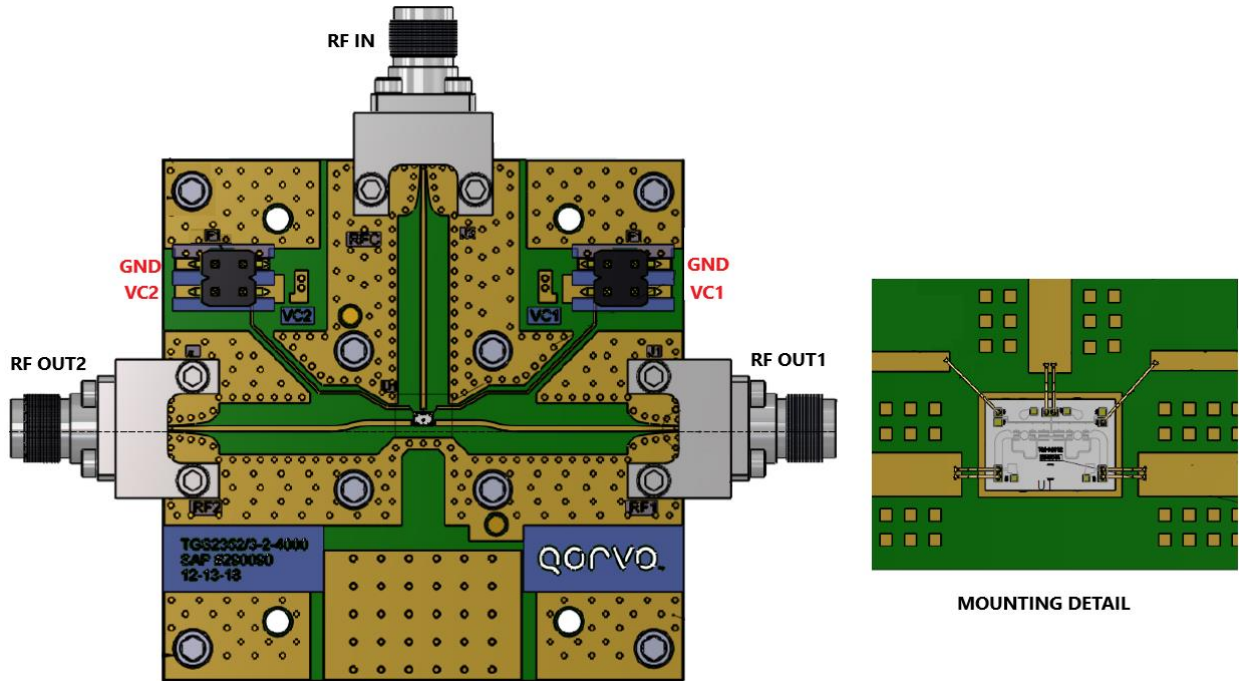

RF Layer is 0.010" thick Rogers Corp. RO4350B, $\epsilon_r = 3.48$. Metal layers are 0.5 oz. copper. The microstrip line at the connector interface is optimized for the Southwest Microwave end launch connector 1092-02A-5.

The pad pattern shown has been developed and tested for optimized assembly at Qorvo Semiconductor. The PCB land pattern has been developed to accommodate lead and package tolerances. Since surface mount processes vary from company to company, careful process development is recommended.

Mechanical Drawing and Bond Pad Description

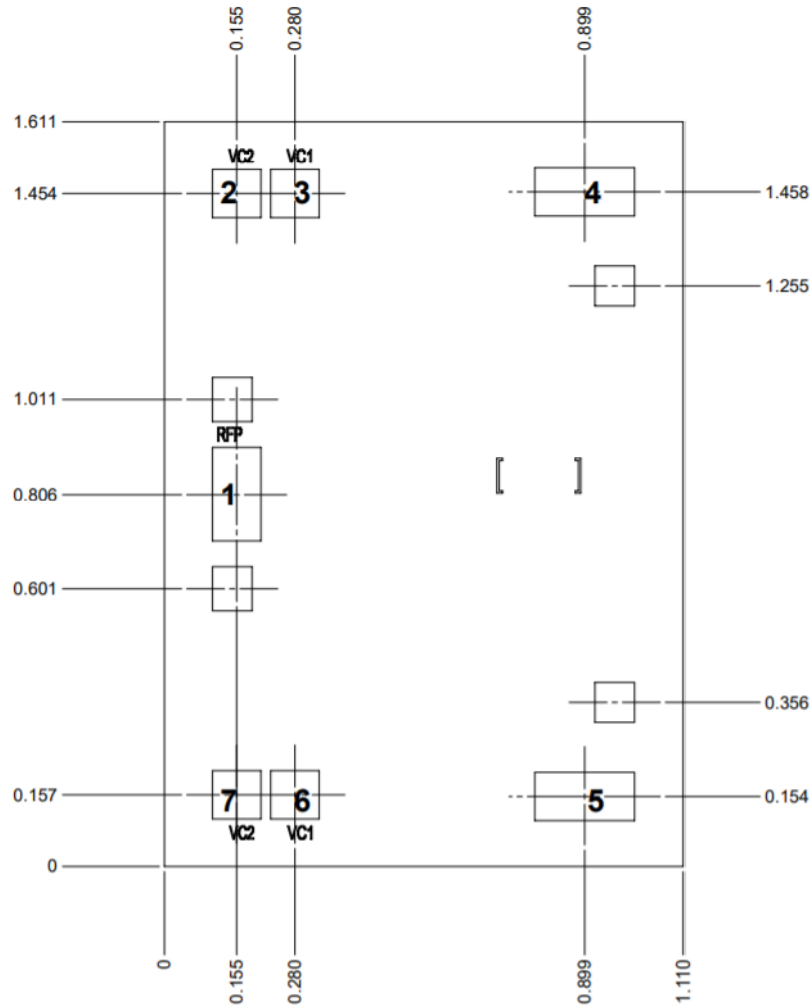

Unit: millimeters
 Thickness: 0.10
 Die x, y size tolerance: +/- 0.050
 Chip edge to bond pad dimensions is shown to center of pad
 Ground is backside of die

Pin No.	Symbol	Description	Pad Size (mm)
1	RF In	Input, RF common port; matched to 50 Ω; DC coupled	0.100 x 0.200
2, 7	V _{C2}	Control voltage 2; can be biased from either side.	0.100 x 0.100
3, 6	V _{C1}	Control voltage 1; can be biased from either side.	0.100 x 0.100
4	RF Out1	Output 1, RF switched port 1; matched to 50 Ω; DC coupled	0.200 x 0.100
5	RF Out2	Output 2, RF switched port 2; matched to 50 Ω; DC coupled	0.200 x 0.100

Assembly Notes

Component placement and adhesive attachment assembly notes:

- Vacuum pencils and/or vacuum collets are the preferred method of pick up.
- Air bridges must be avoided during placement.
- The force impact is critical during auto placement.
- Organic attachment (i.e., conductive epoxy) can be used in low-power applications.
- Curing should be done in a convection oven; proper exhaust is a safety concern.

Reflow process assembly notes:

- Use AuSn (80/20) solder and limit exposure to temperatures above 300 °C to 3–4 minutes, maximum.
- An alloy station or conveyor furnace with reducing atmosphere should be used.
- Do not use any kind of flux.
- Coefficient of thermal expansion matching is critical for long-term reliability.
- Devices must be stored in a dry nitrogen atmosphere.

Interconnect process assembly notes:

- Thermosonic ball bonding is the preferred interconnect technique.
- Force, time, and ultrasonic are critical parameters.
- Aluminum wire should not be used.
- Devices with small pad sizes should be bonded with 0.0007-inch wire.

Handling Precautions

Parameter	Rating	Standard	 Caution! ESD-Sensitive Device
ESD – Human Body Model (HBM)	1A	ESDA / JEDEC JS-001	

Solderability

Use only AuSn (80/20) solder and limit exposure to temperatures above 300 °C to 3-4 minutes, maximum.

RoHS Compliance

This product is compliant with the 2011/65/EU RoHS directive (Restrictions on the Use of Certain Hazardous Substances in Electrical and Electronic Equipment), as amended by Directive 2015/863/EU. This product also has the following attributes:

- Lead Free
- Halogen Free (Chlorine, Bromine)
- Antimony Free
- TBBP-A (C₁₅H₁₂Br₄O₂) Free
- PFOS Free
- SVHC Free

Contact Information

For the latest specifications, additional product information, worldwide sales and distribution locations:

Tel: 1-844-890-8163

Web: www.qorvo.com

Email: customer.support@qorvo.com

Important Notice

The information contained herein is believed to be reliable; however, Qorvo makes no warranties regarding the information contained herein and assumes no responsibility or liability whatsoever for the use of the information contained herein. All information contained herein is subject to change without notice. Customers should obtain and verify the latest relevant information before placing orders for Qorvo products. The information contained herein, or any use of such information does not grant, explicitly or implicitly, to any party any patent rights, licenses, or any other intellectual property rights, whether with regard to such information itself or anything described by such information. **THIS INFORMATION DOES NOT CONSTITUTE A WARRANTY WITH RESPECT TO THE PRODUCTS DESCRIBED HEREIN, AND QORVO HEREBY DISCLAIMS ANY AND ALL WARRANTIES WITH RESPECT TO SUCH PRODUCTS WHETHER EXPRESS OR IMPLIED BY LAW, COURSE OF DEALING, COURSE OF PERFORMANCE, USAGE OF TRADE OR OTHERWISE, INCLUDING THE IMPLIED WARRANTIES OF MERCHANTABILITY AND FITNESS FOR A PARTICULAR PURPOSE.**

Without limiting the generality of the foregoing, Qorvo products are not warranted or authorized for use as critical components in medical, lifesaving, or life-sustaining applications, or other applications where a failure would reasonably be expected to cause severe personal injury or death.

Copyright 2021 © Qorvo, Inc. | Qorvo is a registered trademark of Qorvo, Inc.

Mouser Electronics

Authorized Distributor

Click to View Pricing, Inventory, Delivery & Lifecycle Information:

[Qorvo:](#)

[TGS2352-2](#) [TGS2352-2EVB](#) [TGS2352-2-SMEVB](#)