

### Product Overview

The CMD310 is a sub-harmonically pumped mixer die with an integrated LO amplifier which can be used as an upconverter or downconverter. The device has low conversion loss and excellent 2LO to RF isolation eliminating the need for additional filtering. The CMD310 requires only -4 dBm LO drive and operates on a single positive supply voltage. The sub-harmonic design and low LO drive level allows for less stringent oscillator requirements.

### Functional Block Diagram

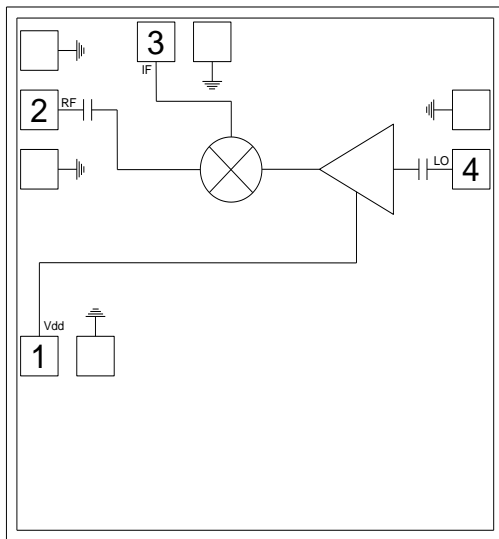

### Key Features

- Integrated LO Amplifier
- High Isolations
- Sub-Harmonic x2 LO
- Single Positive Supply Voltage
- HMC264 Replacement

### Ordering Information

Part No.	Description
CMD310	20-32 GHz Sub-harmonic x2 Mixer, 100 Piece Gel Pack

### Electrical Performance ( $V_{dd} = 4\text{ V}$ , $IF = 100\text{ MHz}$ , $LO = -4\text{ dBm}$ , $RF = 26\text{ GHz}$ , $T_A = 25\text{ }^\circ\text{C}$ )

Parameter	Min	Typ	Max	Units
Frequency Range, RF		20 - 32		GHz
Frequency Range, LO		10 - 16		GHz
Frequency Range, IF	DC		7	GHz
Conversion Loss		9.5		dB
Noise Figure (SSB)		9.5		dB
2LO to RF Isolation		36		dB
2LO to IF Isolation		53		dB
Input IP3		10		dBm
Input P1dB		4.5		dBm
Supply Current	19	27	35	mA

Unless otherwise noted, all measurements performed as a downconverter, IF = 100 MHz USB

## Absolute Maximum Ratings

Parameter	Rating
RF / IF Input Power	+13 dBm
LO Drive	+13 dBm
Drain Voltage, $V_{dd}$	5.5 V
Channel Temperature, $T_{ch}$	150 °C
Power Dissipation, $P_{diss}$	0.33 W
Thermal Resistance, $\theta_{JC}$	199.4 °C/W
Operating Temperature	-55 to 85 °C
Storage Temperature	-55 to 150 °C

Exceeding any one or combination of the maximum ratings may cause permanent damage to the device.

## Recommended Operating Conditions

Parameter	Min	Typ	Max	Units
$V_{dd}$	2	4	5	V
$I_{dd}$		27		mA

Electrical performance is measured at specific test conditions. Electrical specifications are not guaranteed over all recommended operating conditions.

## Electrical Specifications ( $V_{dd} = 4$ V, $I_F = 100$ MHz, $LO = -4$ dBm, $T_A = 25$ °C)

Parameter	Min	Typ	Max	Min	Typ	Max	Units
Frequency Range, RF		20 - 26			26 - 32		GHz
Frequency Range, LO		10 - 13			13 - 16		GHz
Frequency Range, IF		DC - 7			DC - 7		GHz
Conversion Loss		9.5	12.5		10	13	dB
Noise Figure (SSB)		9.5	12.5		10	13	dB
2LO to RF Isolation	25	34		30	40		dB
2LO to IF Isolation	41	52		47	55		dB
Input IP3		8			10		dBm
Input P1dB		3			5		dBm
Supply Current	19	27	35	19	27	35	mA

Unless otherwise noted, all measurements performed as a downconverter,  $I_F = 100$  MHz USB

Typical Performance

Conversion Gain vs. Temperature, LO = -4 dBm, IF = 100 MHz USB

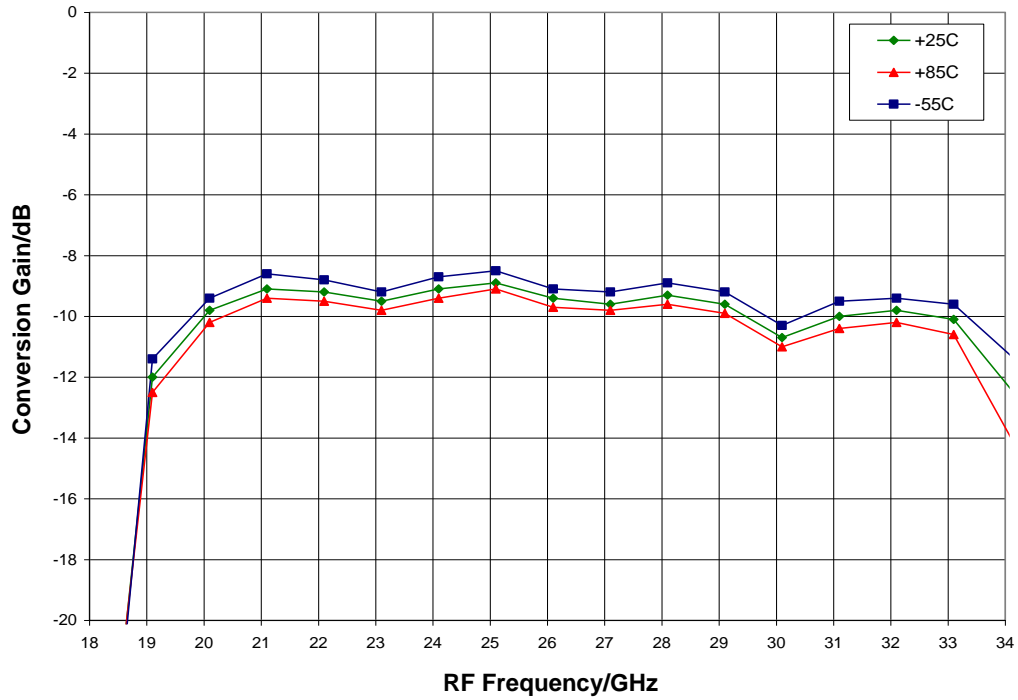

Conversion Gain vs. LO Drive, IF = 100 MHz USB, T<sub>A</sub> = 25 °C

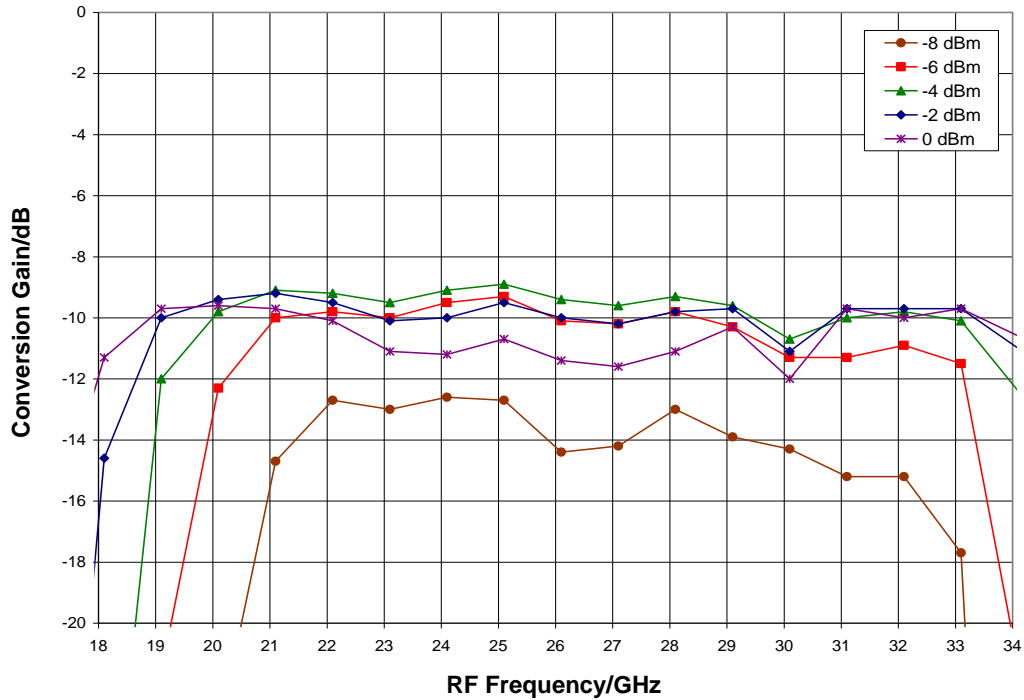

Typical Performance

Isolations, LO = -4 dBm, T<sub>A</sub> = 25 °C

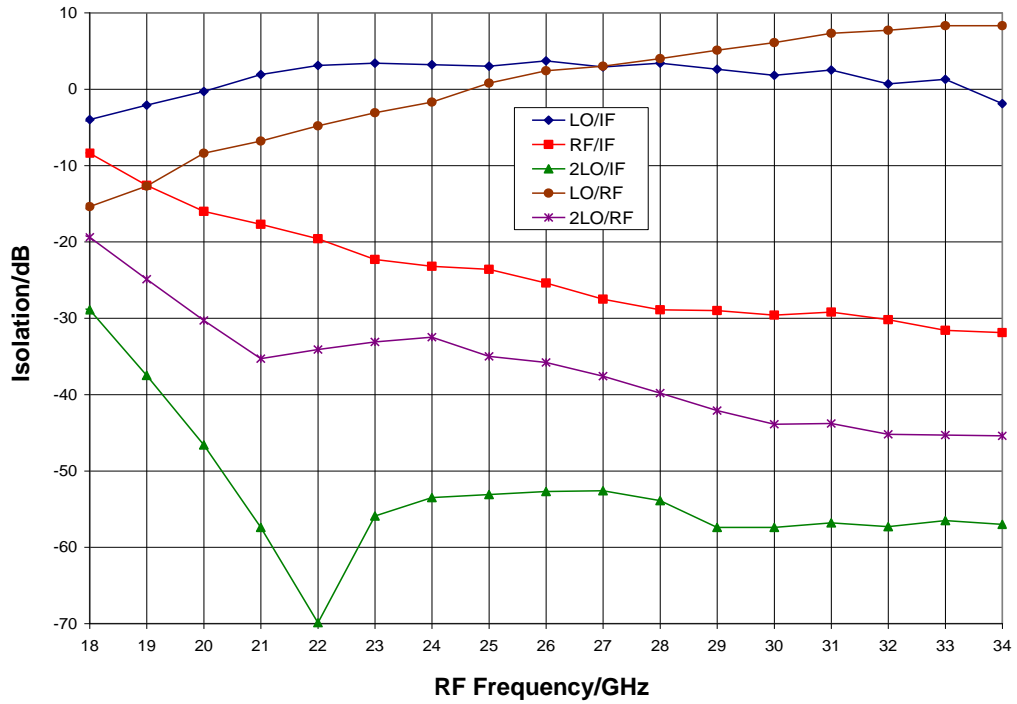

Return Loss, LO = -4 dBm, T<sub>A</sub> = 25 °C

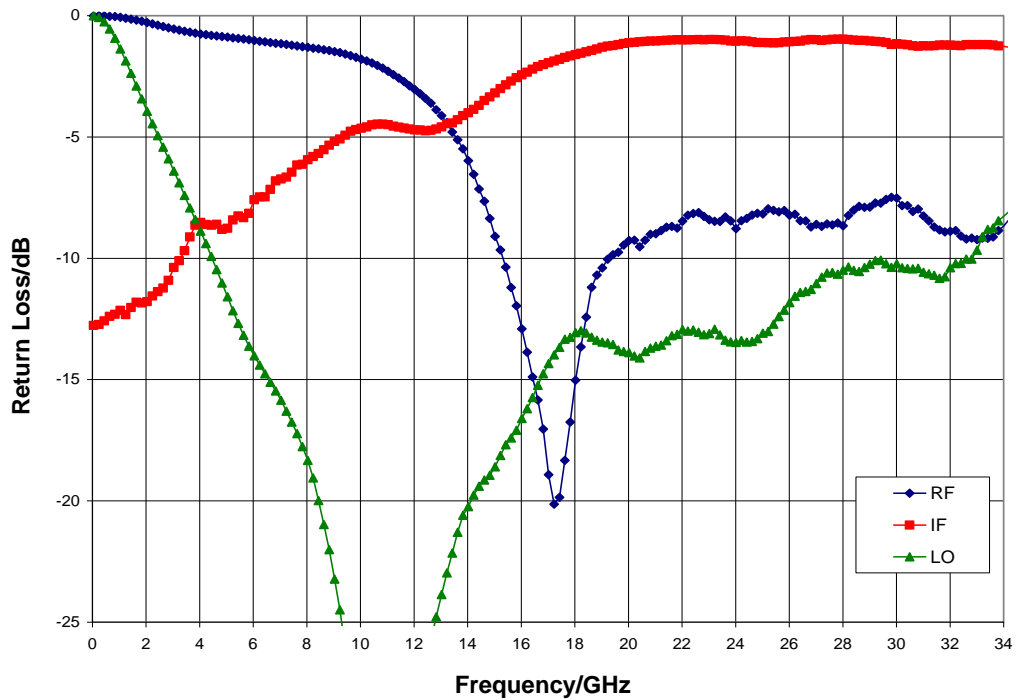

Typical Performance

IF Bandwidth, LO = -4 dBm, T<sub>A</sub> = 25 °C

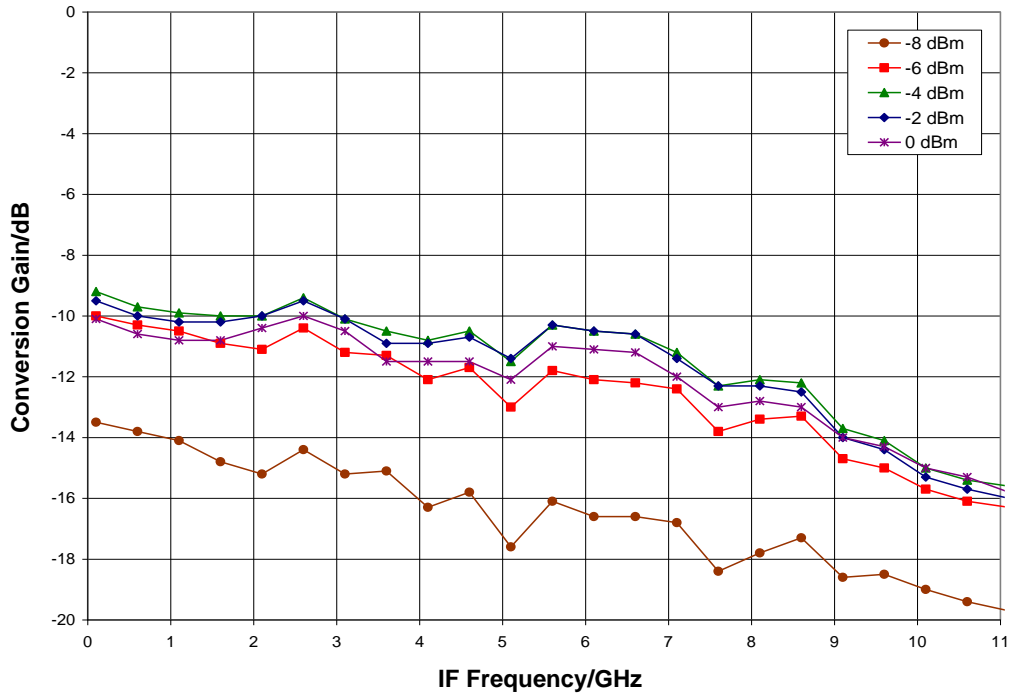

Upconverter Performance, Conversion Gain vs. LO Drive, T<sub>A</sub> = 25 °C

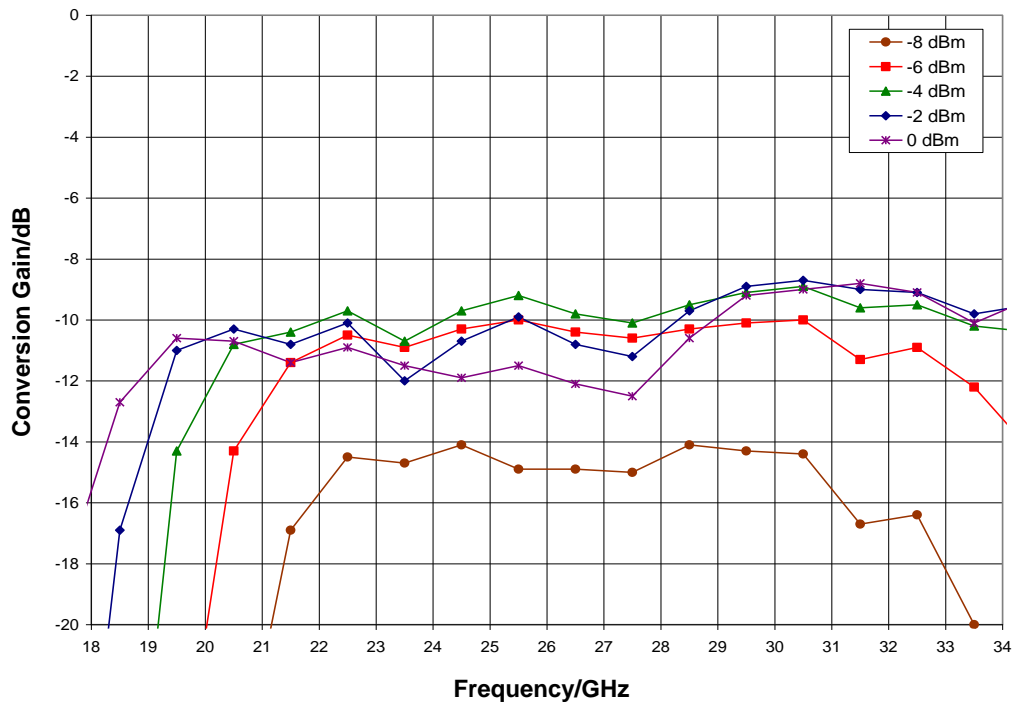

Typical Performance

Input IP3 vs. Temperature, LO = -4 dBm

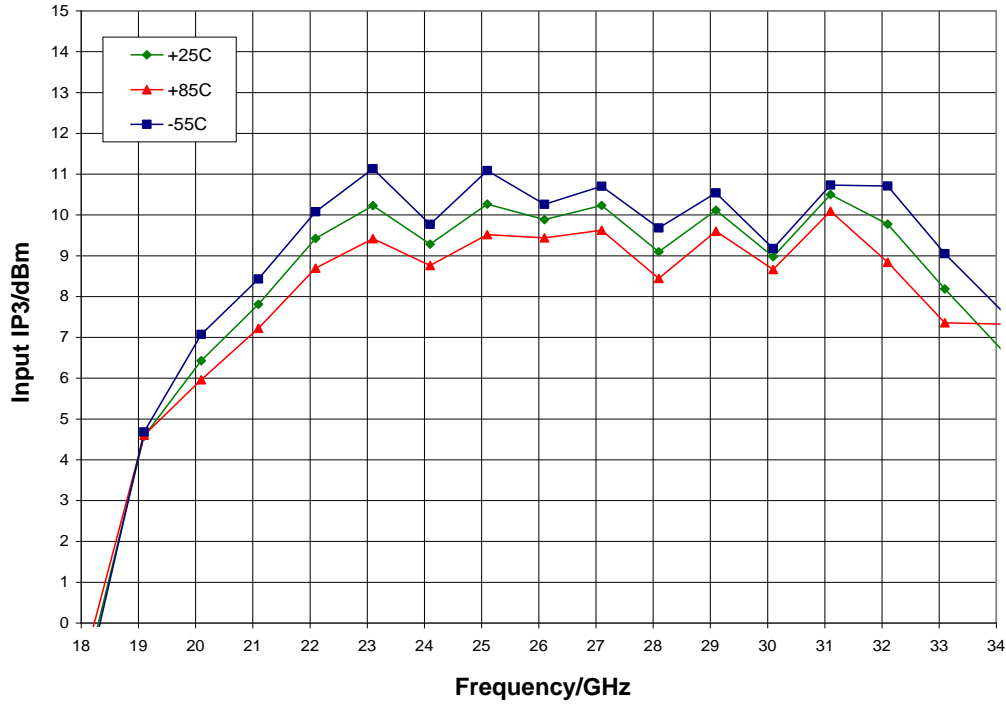

Input IP3 vs. LO Drive, T<sub>A</sub> = 25 °C

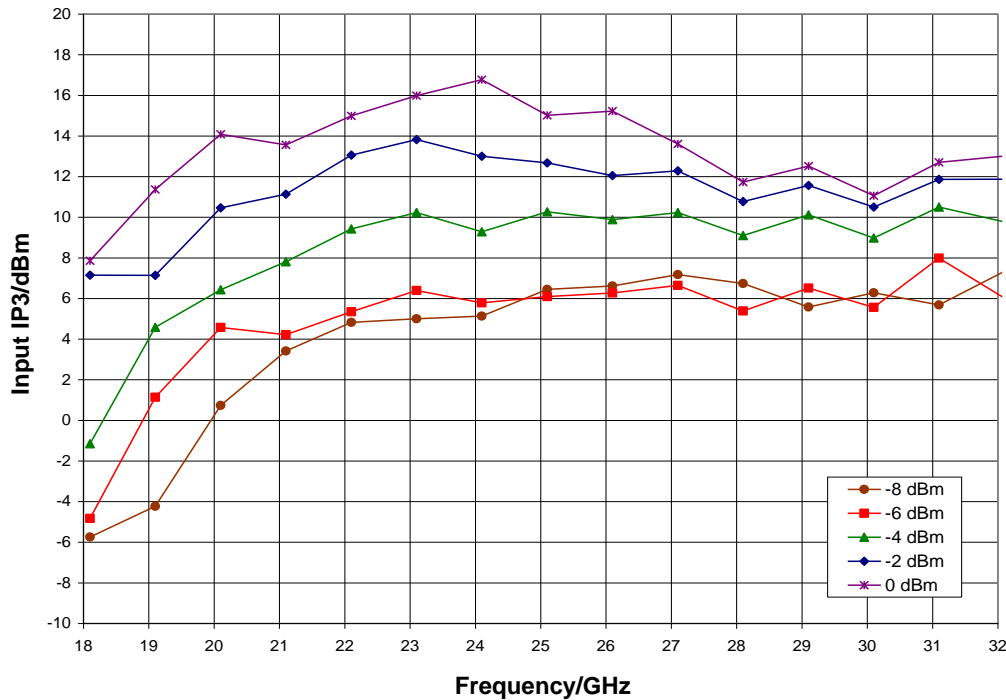

Typical Performance

Input P1dB vs. Temperature, LO = -4 dBm, T<sub>A</sub> = 25 °C

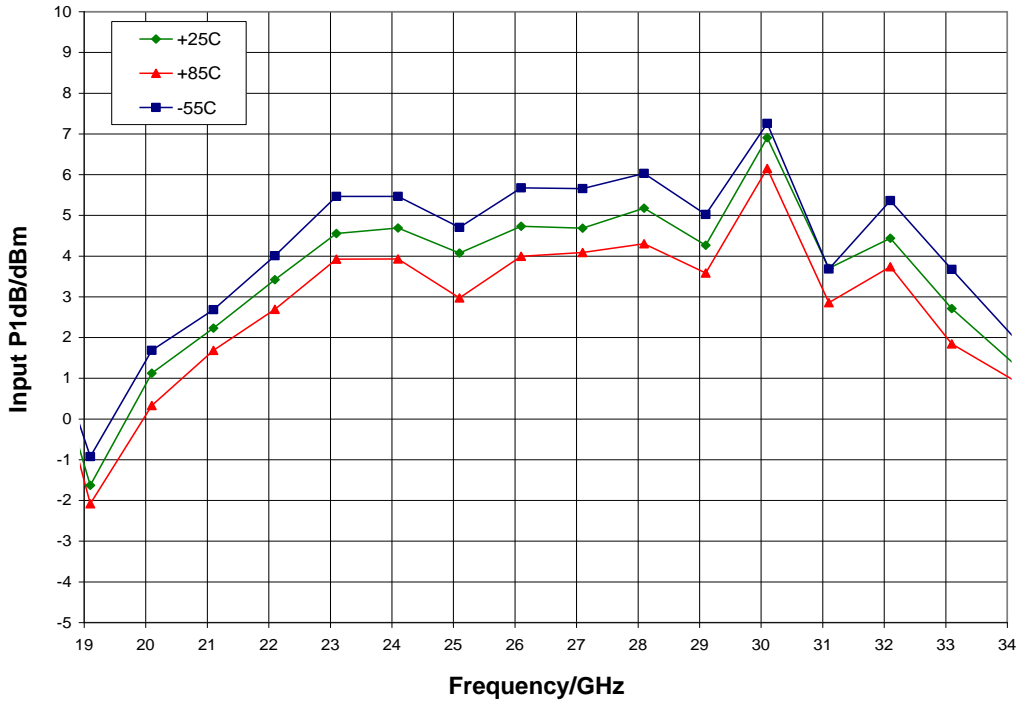

M x N Spur Table

mRF	nLO				
	0	1	2	3	4
0	X	-16	43	29	55
1	21	53	0	55	50
2	71	63	71	44	58
3			71	71	71
4					71

RF = 30 GHz @ -10 dBm  
 LO = 13.6 GHz @ -4 dBm  
 All values in dBc below the IF output power level (1RF - 2LO)

**Mechanical Information**

**Die Outline (all dimensions in microns)**

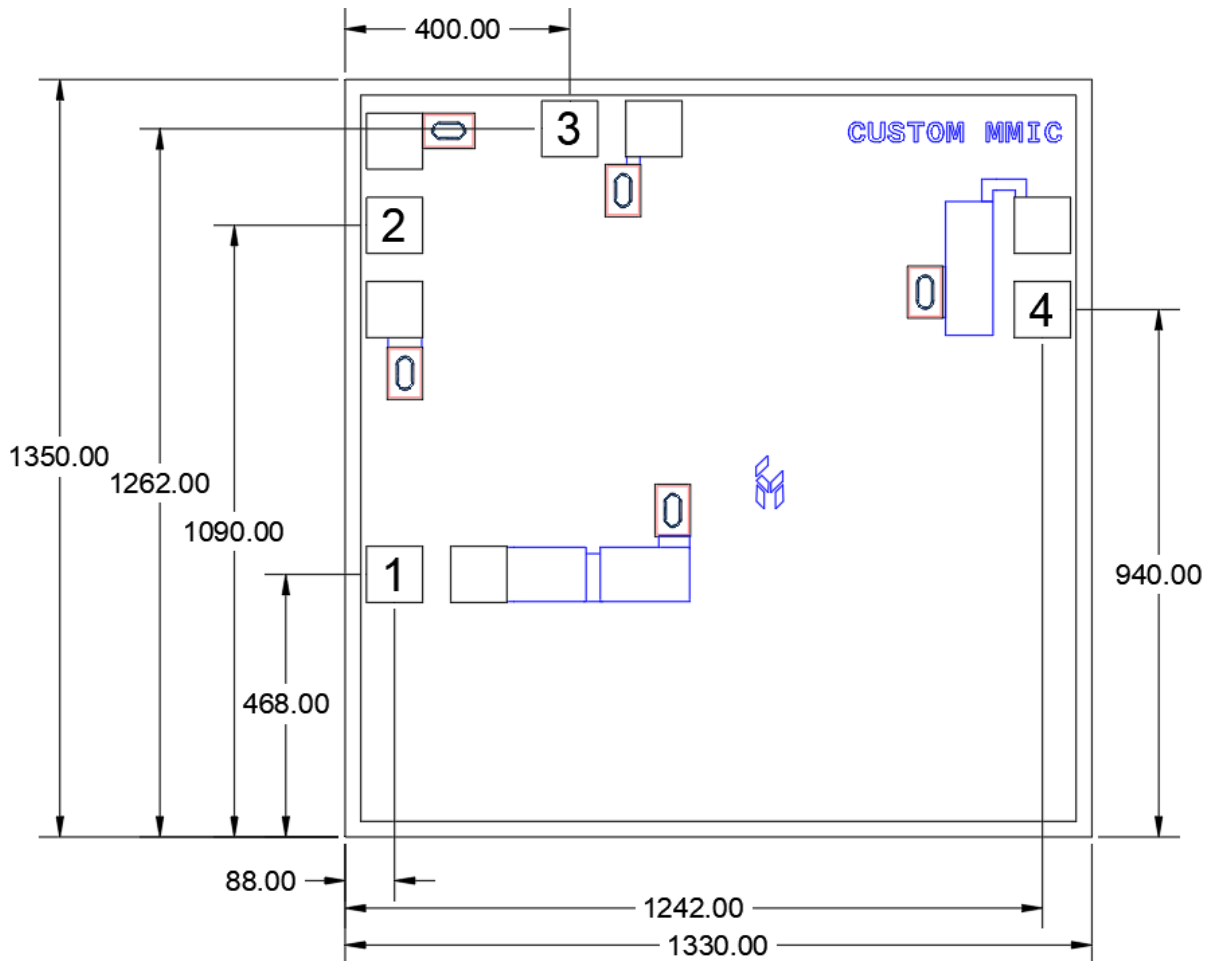

**Notes:**

1. No connection required for unlabeled pads
2. Backside is RF and DC ground
3. Backside and bond pad metal: Gold
4. Die is 100 microns thick
5. All bond pads are 100 x 100 microns square



## Pin Description

### Pad Diagram

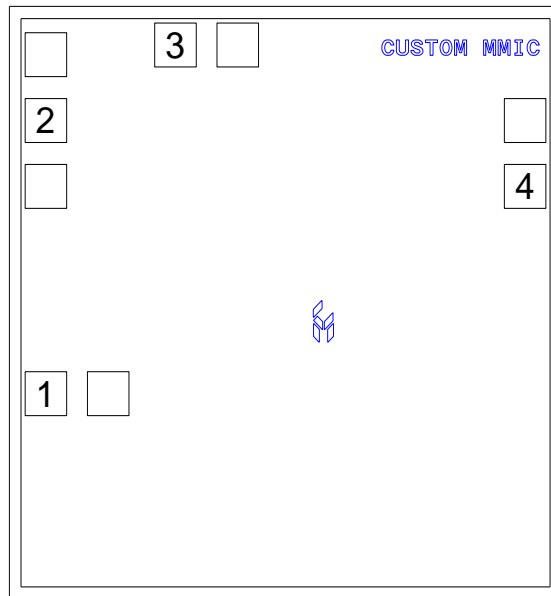

### Functional Description

Pin	Function	Description	Schematic
1	V <sub>dd</sub>	Power supply voltage Decoupling and bypass caps required	
2	RF	DC blocked and 50 ohm matched	
3	IF	This pin is DC coupled and should be DC blocked externally using a series capacitor whose value has been chosen to pass the necessary IF frequency. Any applied DC voltage to this pin will result in die non-function and possible die failure	
4	LO	DC blocked and 50 ohm matched	
Backside	Ground	Connect to RF / DC ground	

Applications Information

Assembly Guidelines

The backside of the CMD310 is RF ground. Die attach should be accomplished with electrically and thermally conductive epoxy only. Eutectic attach is not recommended. Standard assembly procedures should be followed for high frequency devices. The top surface of the semiconductor should be made planar to the adjacent RF transmission lines.

RF connections should be made as short as possible to reduce the inductive effect of the bond wire. Use of a 0.8 mil thermosonic wedge bonding is highly recommended as the loop height will be minimized.

The semiconductor is 100 um thick and should be handled by the sides of the die or with a custom collet. Do not make contact directly with the die surface as this will damage the monolithic circuitry. Handle with care.

Assembly Diagram

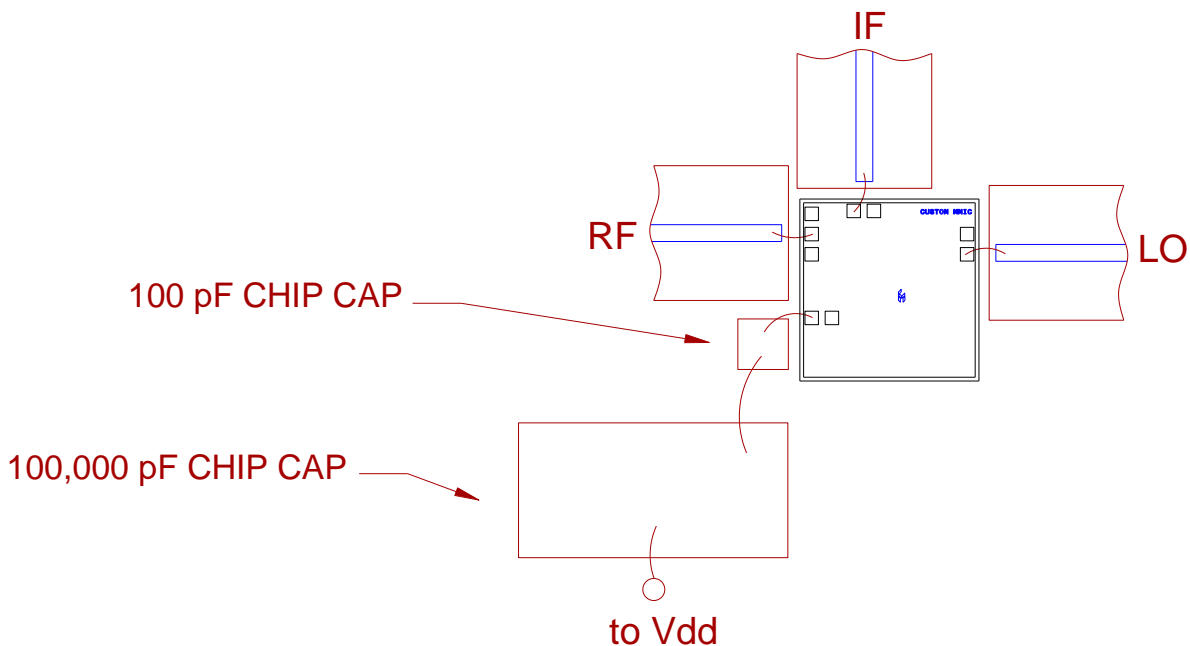

**GaAs MMIC devices are susceptible to damage from Electrostatic Discharge. Proper precautions should be observed during handling, assembly and test.**

## Handling Precautions

Parameter	Rating	Standard
ESD – Human Body Model (HBM)	Class 1A	ESDA / JEDEC JS-001-2012



Caution!  
ESD-Sensitive Device

## RoHS Compliance

This part is compliant with 2011/65/EU RoHS directive (Restrictions on the Use of Certain Hazardous Substances in Electrical and Electronic Equipment) as amended by Directive 2015/863/EU.

This product also has the following attributes:

- Lead Free
- Antimony Free
- TBBP-A (C<sub>15</sub>H<sub>12</sub>Br<sub>4</sub>O<sub>2</sub>) Free
- SVHC Free
- Halogen Free
- PFOS Free

## Contact Information

For the latest specifications, additional product information, worldwide sales and distribution locations:

**Web:** [www.qorvo.com](http://www.qorvo.com)

**Tel:** 1-844-890-8163

**Email:** [customer.support@qorvo.com](mailto:customer.support@qorvo.com)

## Important Notice

The information contained in this Data Sheet and any associated documents (“Data Sheet Information”) is believed to be reliable; however, Qorvo makes no warranties regarding the Data Sheet Information and assumes no responsibility or liability whatsoever for the use of said information. All Data Sheet Information is subject to change without notice. Customers should obtain and verify the latest relevant Data Sheet Information before placing orders for Qorvo® products. Data Sheet Information or the use thereof does not grant, explicitly, implicitly or otherwise any rights or licenses to any third party with respect to patents or any other intellectual property whether with regard to such Data Sheet Information itself or anything described by such information.

DATA SHEET INFORMATION DOES NOT CONSTITUTE A WARRANTY WITH RESPECT TO THE PRODUCTS DESCRIBED HEREIN, AND QORVO HEREBY DISCLAIMS ANY AND ALL WARRANTIES WITH RESPECT TO SUCH PRODUCTS WHETHER EXPRESS OR IMPLIED BY LAW, COURSE OF DEALING, COURSE OF PERFORMANCE, USAGE OF TRADE OR OTHERWISE, INCLUDING THE IMPLIED WARRANTIES OF MERCHANTABILITY AND FITNESS FOR A PARTICULAR PURPOSE. Without limiting the generality of the foregoing, Qorvo® products are not warranted or authorized for use as critical components in medical, life-saving, or life-sustaining applications, or other applications where a failure would reasonably be expected to cause severe personal injury or death. Applications described in the Data Sheet Information are for illustrative purposes only. Customers are responsible for validating that a particular product described in the Data Sheet Information is suitable for use in a particular application.

© 2022 Qorvo US, Inc. All rights reserved. This document is subject to copyright laws in various jurisdictions worldwide and may not be reproduced or distributed, in whole or in part, without the express written consent of Qorvo US, Inc. | QORVO® is a registered trademark of Qorvo US, Inc.