

Product Overview

The Qorvo QPD1026L is a 1300 W (P_{3dB}) discrete GaN on SiC HEMT which operates from 420 to 450 MHz. Input pre-match within the package results in ease of external board match and saves board space. The device is in an industry standard air cavity package and is ideally suited for amateur radio, public safety radio and radiolocation service. The device can support both CW and pulsed operations.

RoHS compliant

Evaluation boards are available upon request.



4-lead NI-1230 Package (Eared)

Functional Block Diagram

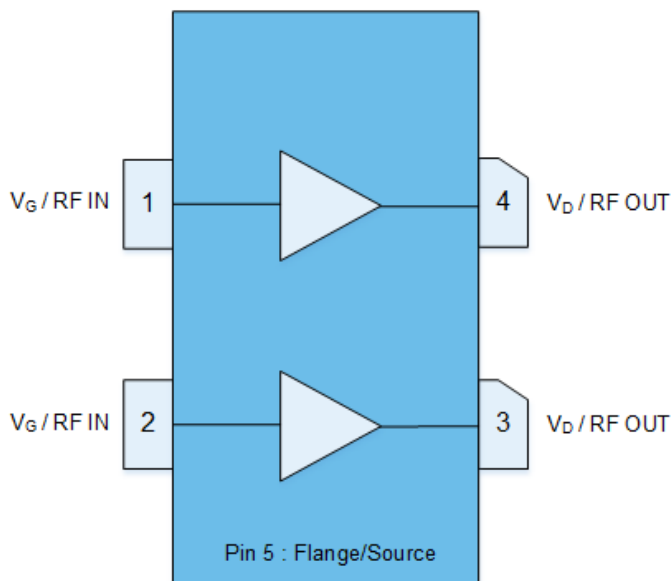

Key Features

- Frequency: 420 to 450 MHz
- Output Power (P_{3dB})¹: 1318 W
- Linear Gain¹: 25.9 dB
- Typical PAE_{3dB}¹: 80.8 %
- Operating Voltage: 65 V
- CW and Pulse capable

Note 1: @ 440 MHz Load Pull

Applications

- UHF Radar
- Amateur Radio
- Public Safety Radio
- Radiolocation Service

Ordering info

Part No.	Description
QPD1026L	420 – 450 MHz Transistor
QPD1026LEVB1	432 – 442 MHz Evaluation Board



Absolute Maximum Ratings ^{1, 2, 3}

Parameter	Rating	Units
Breakdown Voltage, BV_{DG}	225	V
Gate Voltage Range, V_G	-7 to +2	V
Drain Current, $I_{D_{MAX}}$	142	A
Gate Current Range, I_G	See pg. 4	mA
Power Dissipation, Pulsed, P_{DISS}^2	1000	W
RF Input Power, Pulsed, P_{IN}^3	43.2	dBm
Mounting Temperature (30 Seconds)	320	°C
Storage Temperature	-65 to +150	°C

Notes:

1. Operation of this device outside the parameter ranges given above may cause permanent damage
2. Pulsed, 500us PW, 5% DC, Package base at 85 °C
3. Pulsed, 500us PW, 5% DC, T = 25 °C

Recommended Operating Conditions ^{1, 2, 3, 4}

Parameter	Min	Typ	Max	Units
Operating Temp. Range	-40	+25	+85	°C
Drain Voltage Range, V_D	-	+65	+70	V
Drain Bias Current, I_{DQ}		1.5		A
Drain Current, I_D^4	-	28	-	A
Gate Voltage, V_G^3	-	-2.8	-	V
Power Dissipation (P_D) ^{2,4}	-	-	907	W
Power Dissipation (P_D), CW ²	-	-	510	W

Notes:

1. Electrical performance is measured under conditions noted in the electrical specifications table. Specifications are not guaranteed over all recommended operating conditions
2. Package base at 85 °C
3. To be adjusted to desired I_{DQ}
4. Pulsed, 500us PW, 5% DC

Measured Load Pull Performance – 65V Power Tuned ^{1, 2}

Parameter	Typical Values				Units
	420	430	440	450	
Frequency, F	420	430	440	450	MHz
Output Power at 3dB compression, P_{3dB}	59.3	59.2	59.2	59.1	dBm
Power Added Efficiency at 3dB compression, PAE_{3dB}	59.1	60.0	64.5	69.0	%
Gain at 3dB compression, G_{3dB}	23.7	24.6	23.8	24.6	dB

Notes:

1. Test conditions unless otherwise noted: $T_A = 25\text{ °C}$, $V_D = 65\text{ V}$, $I_{DQ} = 750\text{ mA}$ (half device)
2. Pulsed, 500 us Pulse Width, 5% Duty Cycle.

Measured Load Pull Performance – 65V Efficiency Tuned ^{1, 2}

Parameter	Typical Values				Units
	420	430	440	450	
Frequency, F	420	430	440	450	MHz
Output Power at 3dB compression, P_{3dB}	56.7	56.4	57.5	57.3	dBm
Power Added Efficiency at 3dB compression, PAE_{3dB}	78.9	79.7	80.8	80.6	%
Gain at 3dB compression, G_{3dB}	27.5	26.4	25.9	26.3	dB

Notes:

1. Test conditions unless otherwise noted: $T_A = 25\text{ °C}$, $V_D = 65\text{ V}$, $I_{DQ} = 750\text{ mA}$ (half device)
2. Pulsed, 500 us Pulse Width, 5% Duty Cycle.

RF Characterization – 432 – 442 MHz EVB Performance at 442 MHz ¹

Parameter	Min	Typ	Max	Units
Linear Gain, G_{LIN}	–	23.6	–	dB
Output Power at 3dB compression point, P3dB	–	1114	–	W
Drain Efficiency at 3dB compression point, DEFF3dB	–	81.6	–	%
Gain at 3dB compression point, G3dB	–	20.6	–	dB

Notes:

1. $V_D = 65\text{ V}$, $I_{DQ} = 1.5\text{ A}$ (combined), Temp = +25 °C, Pulse Width = 500 us, Duty Cycle = 5%

RF Characterization – Mismatch Ruggedness at 442 MHz ^{1, 2, 3}

Symbol	Parameter	dB Compression	Typical
VSWR	Impedance Mismatch Ruggedness	3	6:1

Notes:

1. Test conditions unless otherwise noted: $T_A = 25\text{ °C}$, $V_D = 65\text{ V}$, $I_{DQ} = 1.5\text{ A}$ (combined)
2. Input drive power is determined at pulsed 3dB compression under matched condition at EVB output connector
3. Pulse: 500us, 5% Duty cycle

Maximum Gate Current

Maximum Gate Current vs. IR Surface Temperature

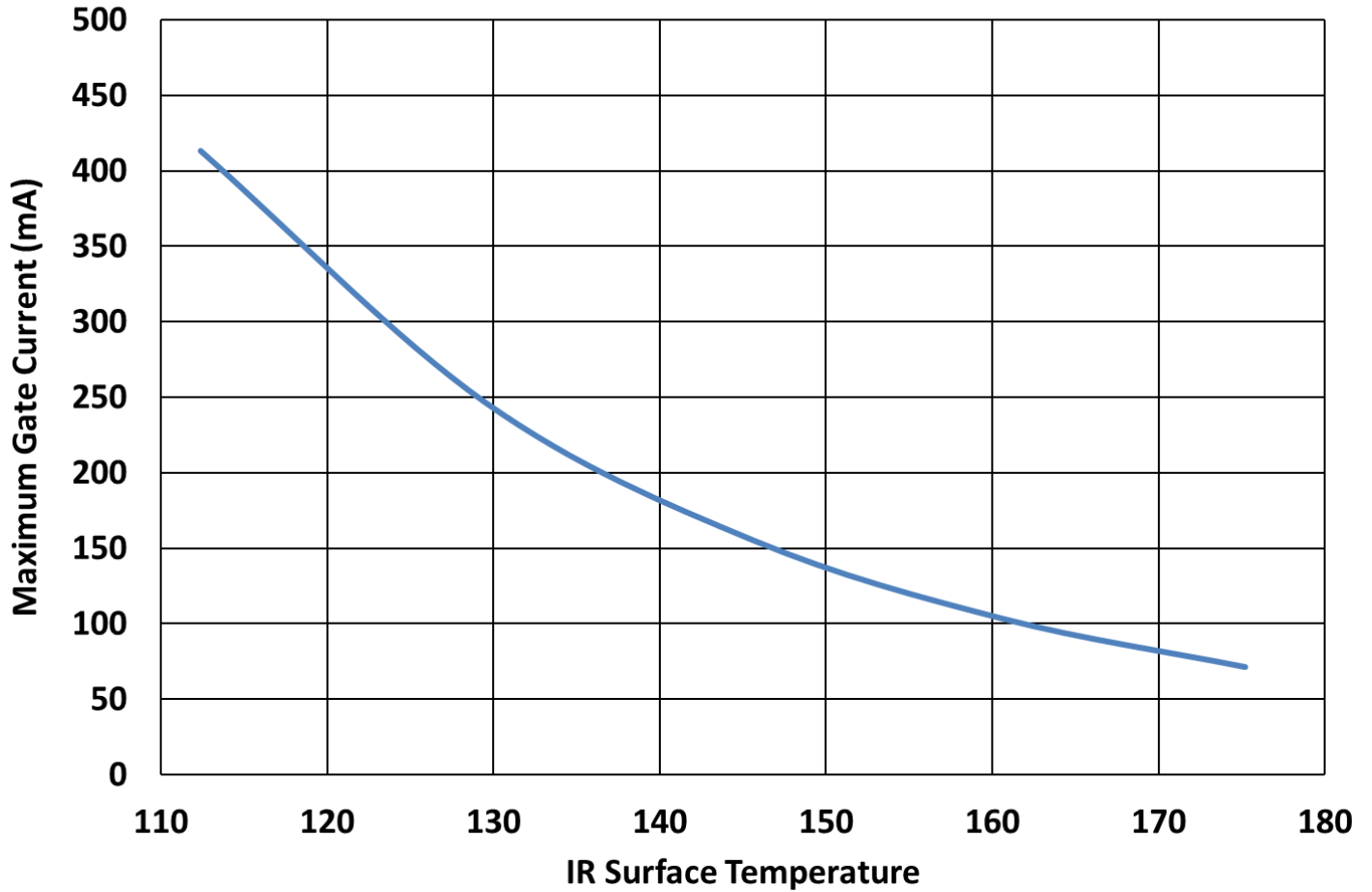

Thermal and Reliability Information ¹

Peak IR Surface Temperature vs. Pulse Width
 (Push-Pull Operation, Base fixed at 85 °C, P_{diss} Varies)

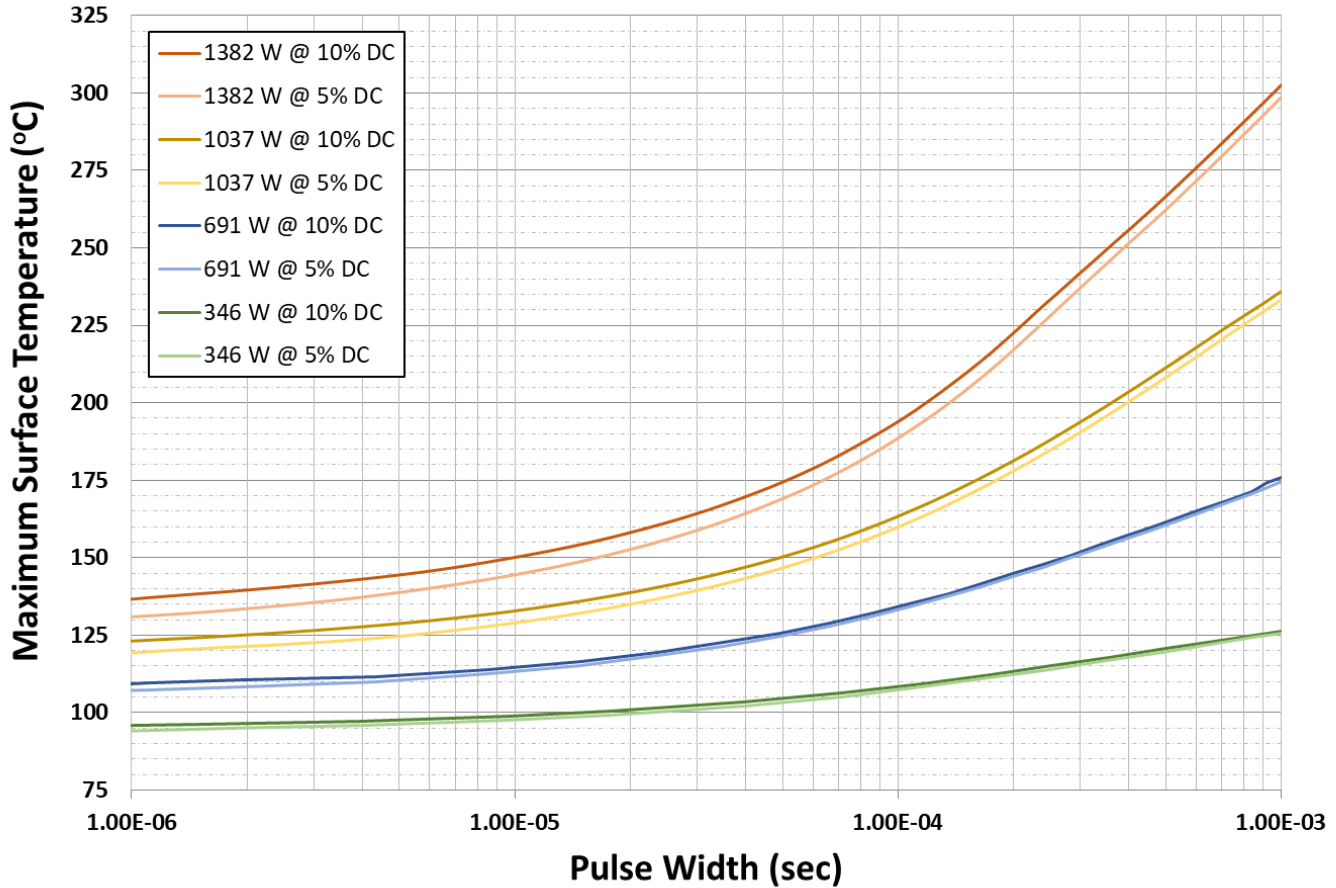

Parameter	Conditions	Values	Units
Thermal Resistance, IR ¹ (θ_{JC})	85 °C Case backside Temperature	0.10	°C/W
Peak IR Surface Temperature ¹ (T_{ch})	P _{diss} = 346 W, Pulse: 500 us PW, 5% DC	120	°C

Note:

1. Refer to the following document [GaN Device Channel Temperature, Thermal Resistance, and Reliability Estimates](#)

Measured Load-Pull Smith Charts at 65V ^{1, 2, 3}

Notes:

1. Test Conditions: $V_D = 65\text{ V}$, $I_{DQ} = 750\text{ mA}$, 500 us Pulse Width, 5% Duty Cycle, Temp = 25°C.
2. The performance shown below is for only half of the device out of the two independent amplification paths.
3. See "Pin Configuration and Description" for load pull reference planes where the performance was measured.

0.42GHz, Load-pull

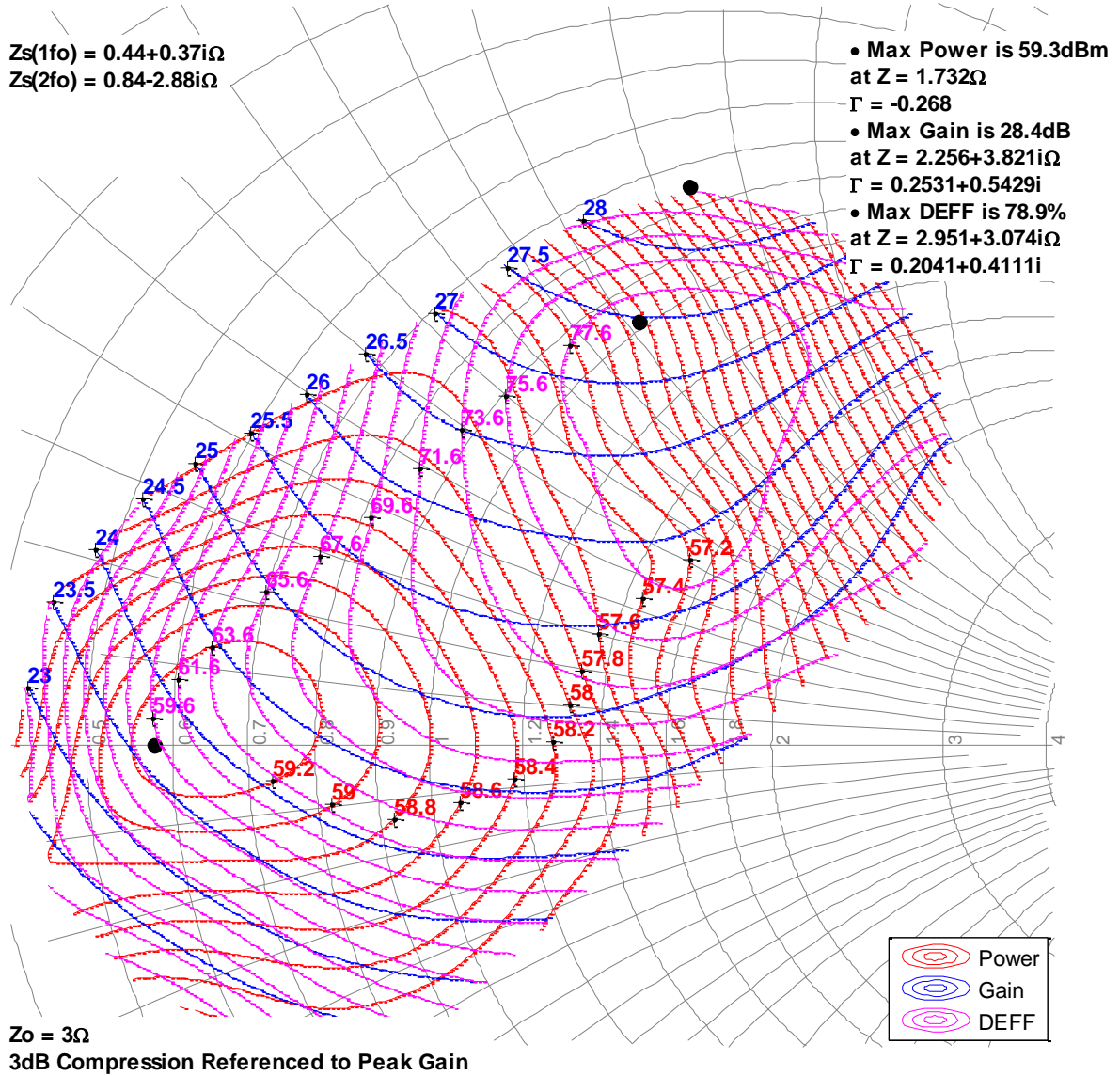

Measured Load-Pull Smith Charts at 65V ^{1, 2, 3}

Notes:

1. Test Conditions: $V_D = 65\text{ V}$, $I_{DQ} = 750\text{ mA}$, 500 us Pulse Width, 5% Duty Cycle, Temp = 25°C.
2. The performance shown below is for only half of the device out of the two independent amplification paths.
3. See "Pin Configuration and Description" for load pull reference planes where the performance was measured.

0.43GHz, Load-pull

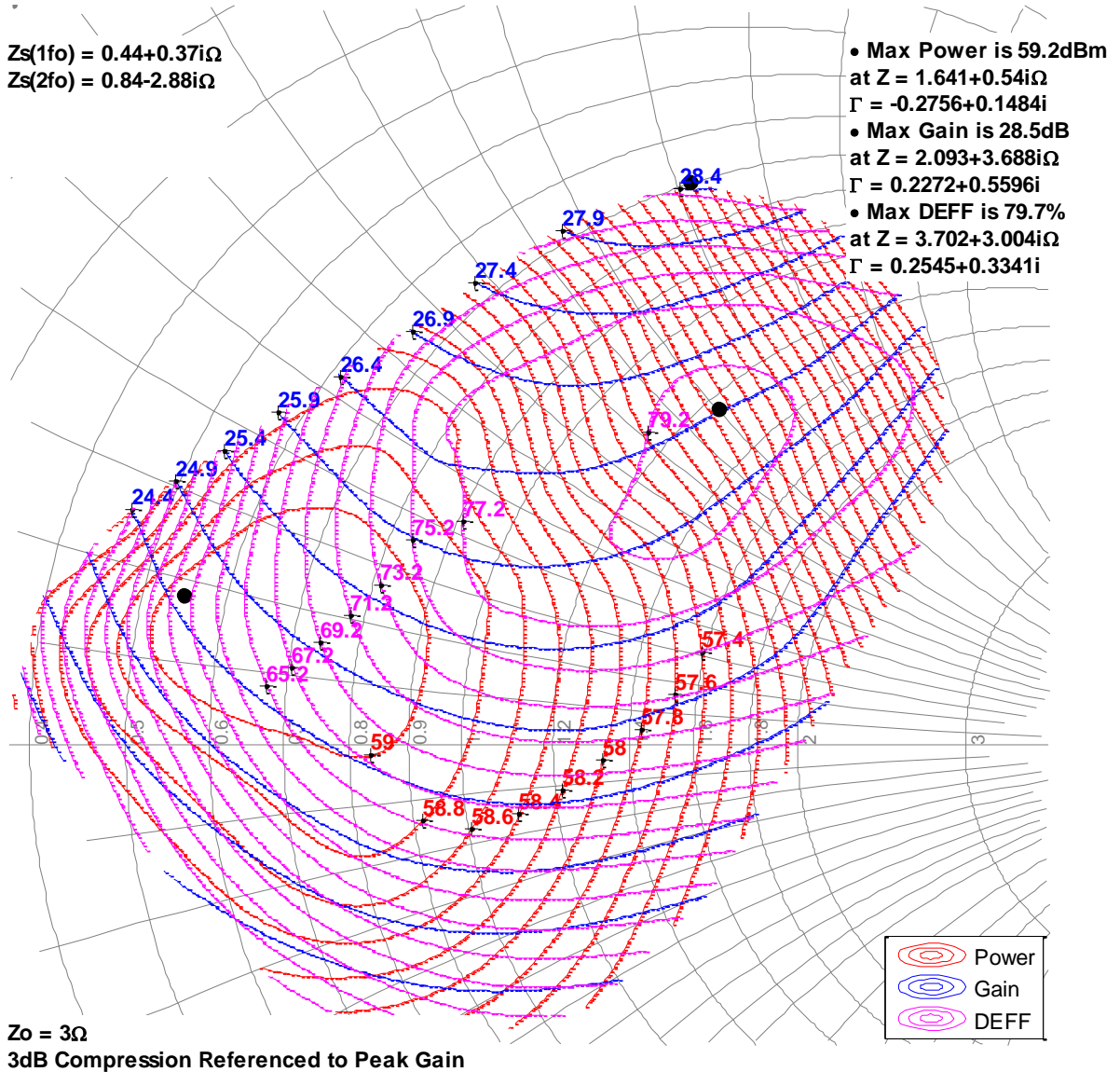

Measured Load-Pull Smith Charts at 65V 1, 2, 3

Notes:

1. Test Conditions: $V_D = 65\text{ V}$, $I_{DQ} = 750\text{ mA}$, 500 us Pulse Width, 5% Duty Cycle, Temp = 25°C.
2. The performance shown below is for only half of the device out of the two independent amplification paths.
3. See "Pin Configuration and Description" for load pull reference planes where the performance was measured.

0.44GHz, Load-pull

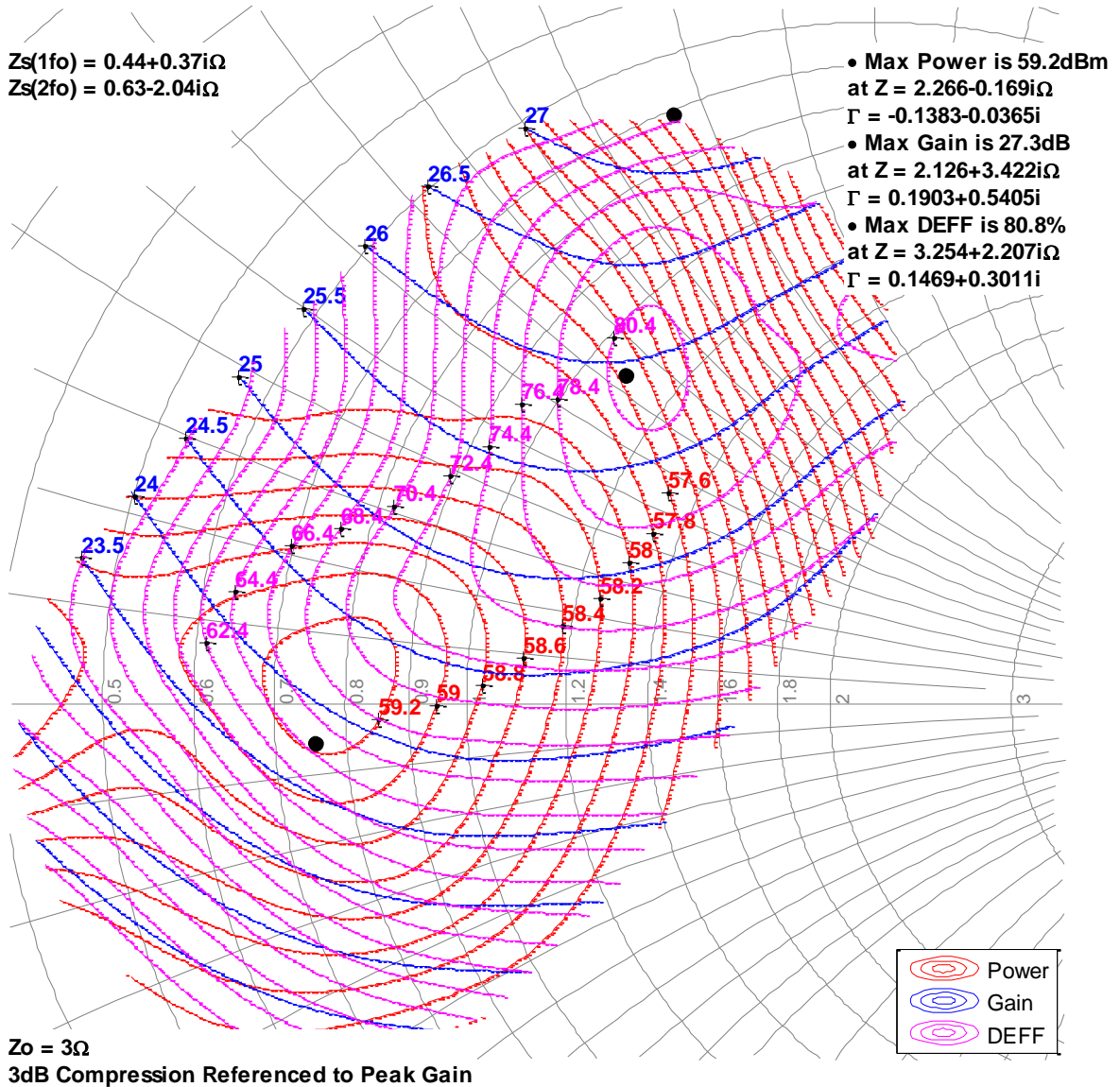

Measured Load-Pull Smith Charts at 65V ^{1, 2, 3}

Notes:

1. Test Conditions: $V_D = 65\text{ V}$, $I_{DQ} = 750\text{ mA}$, 500 us Pulse Width, 5% Duty Cycle, Temp = 25°C.
2. The performance shown below is for only half of the device out of the two independent amplification paths.
3. See "Pin Configuration and Description" for load pull reference planes where the performance was measured.

0.45GHz, Load-pull

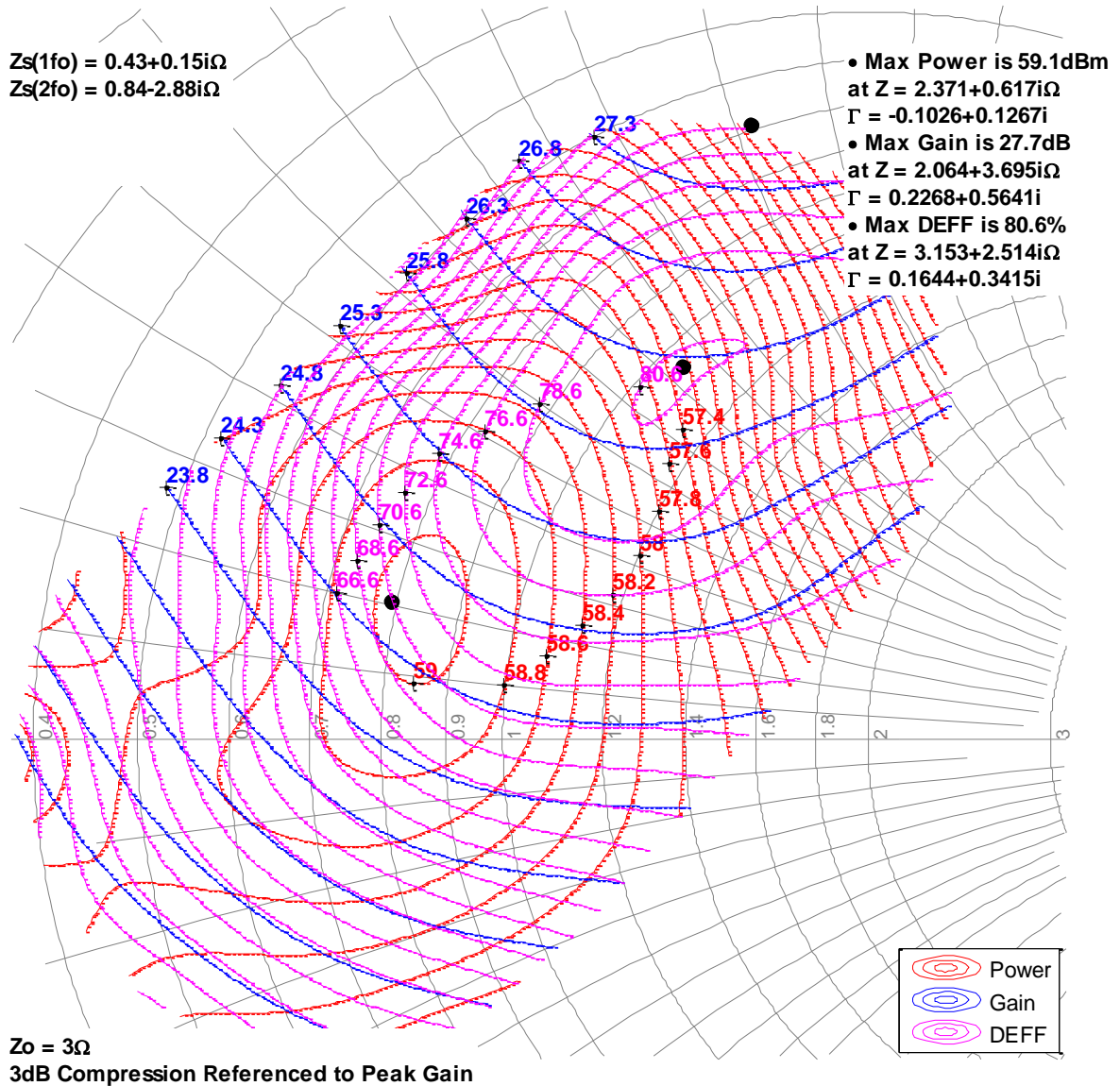

Typical Measured Performance – Load-Pull Drive-up at 65V ^{1, 2, 3}

Notes:

1. Test Conditions: $V_D = 65\text{ V}$, $I_{DQ} = 750\text{ mA}$, 500 us Pulse Width, 5% Duty Cycle, Temp = 25°C.
2. The performance shown below is for only half of the device out of the two independent amplification paths.
3. See "Pin Configuration and Description" for load pull reference planes where the performance was measured.

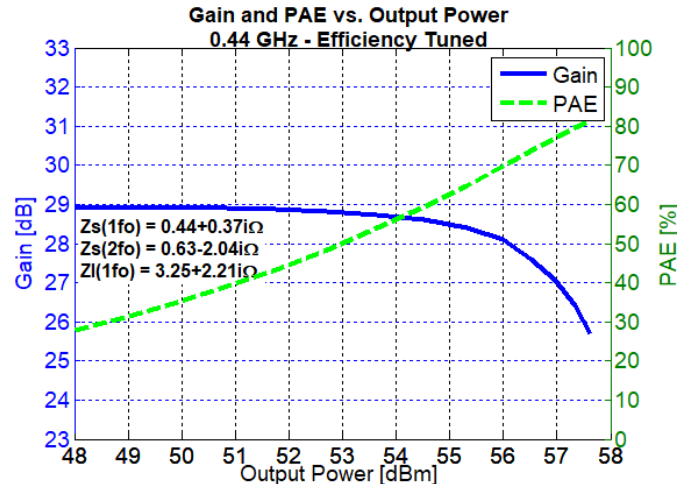
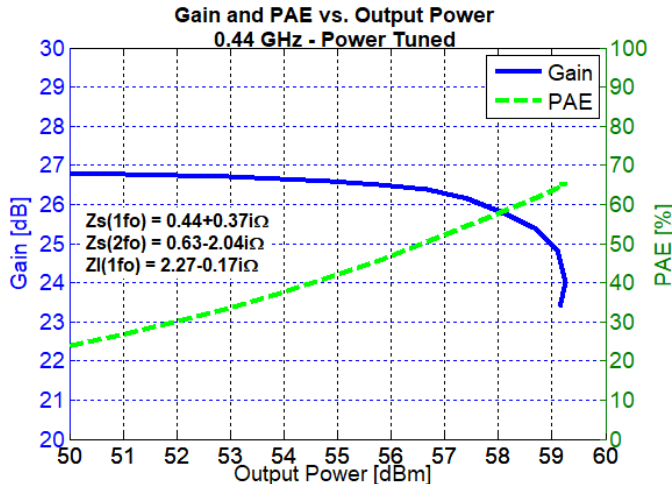
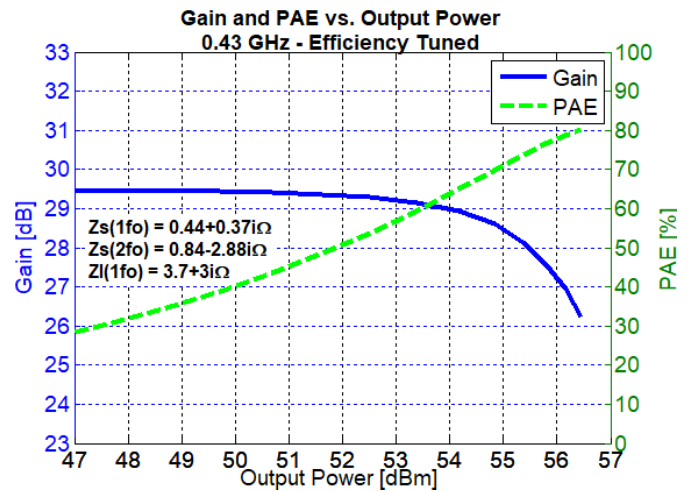
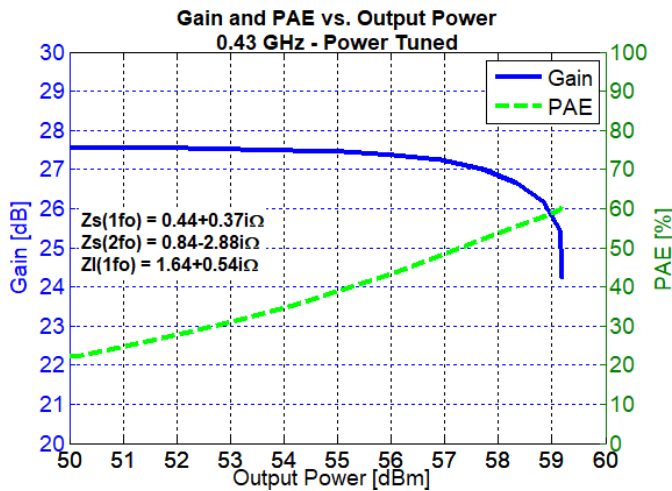
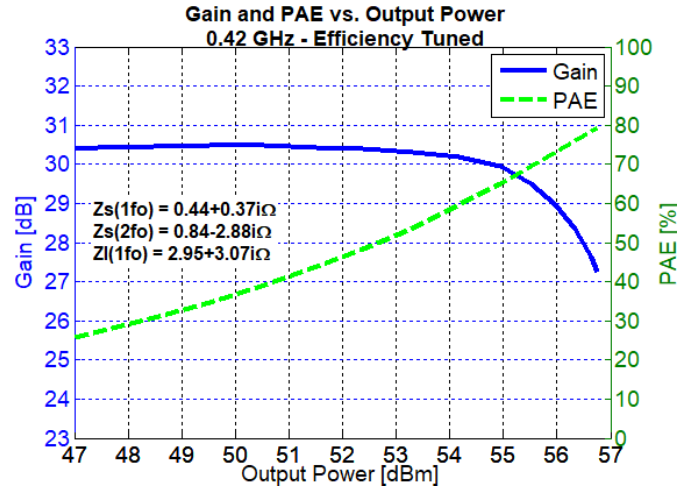
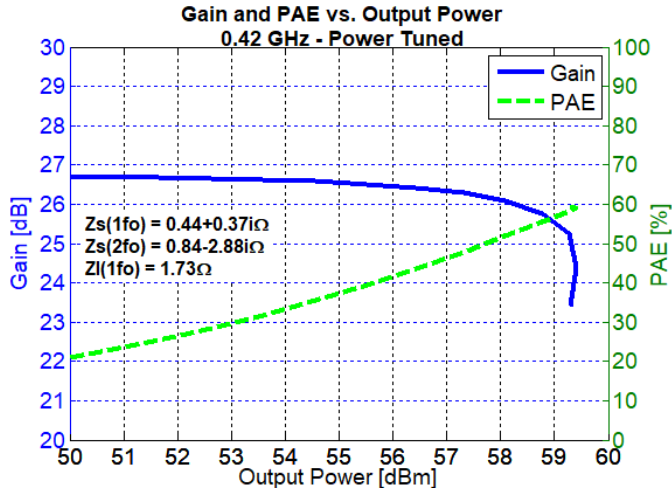

Typical Measured Performance – Load-Pull Drive-up at 65V ^{1, 2, 3}

Notes:

1. Test Conditions: $V_D = 65\text{ V}$, $I_{DQ} = 750\text{ mA}$, 500 us Pulse Width, 5% Duty Cycle, Temp = 25°C.
2. The performance shown below is for only half of the device out of the two independent amplification paths.
3. See "Pin Configuration and Description" for load pull reference planes where the performance was measured.

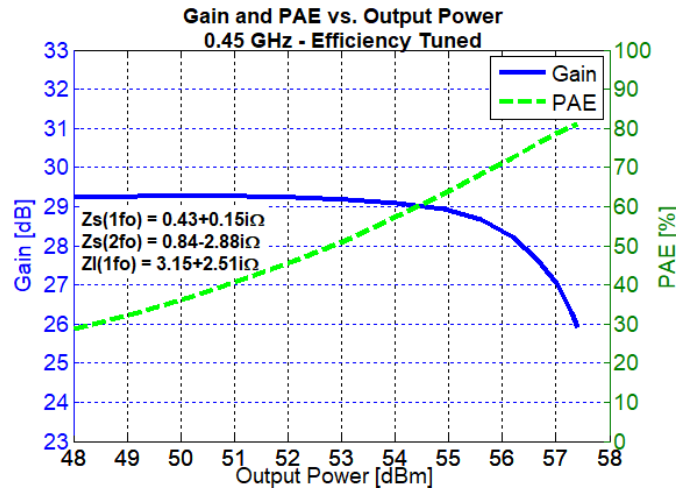
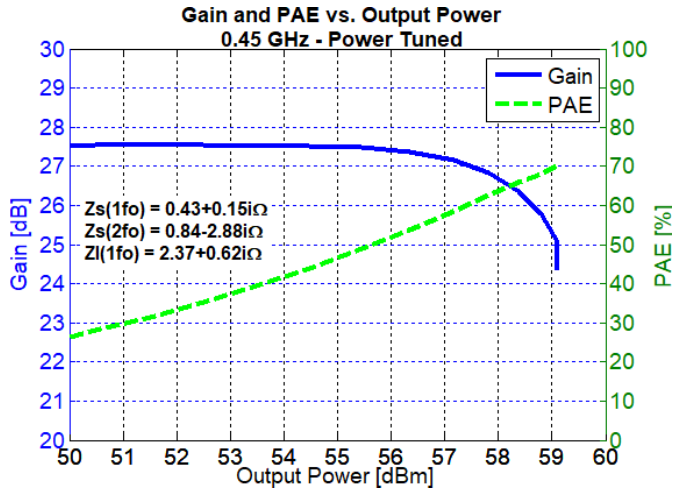

Pin Configuration and Description ¹

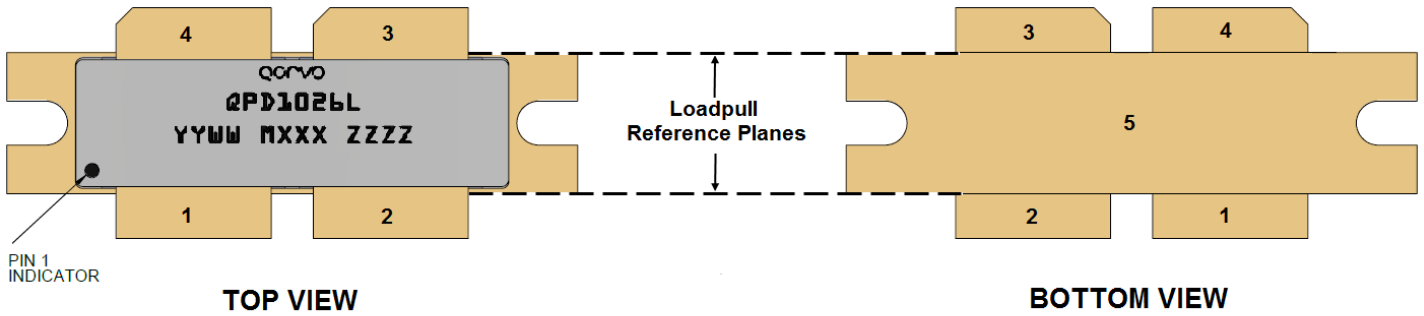

Note:

- The QPD1026L will be marked with the “QPD1026L” designator and a lot code marked below the part designator. The “YY” represents the last two digits of the calendar year the part was manufactured, the “WW” is the work week of the assembly lot start, the “MXXX” is the production lot number, and the “ZZZ” is an auto-generated serial number.

Pin Description

Pin	Symbol	Description
1, 2	RF IN / V_G	Gate
3, 4	RF OUT / V_D	Drain
5	Source	Source / Ground / Backside of part

Mechanical Drawing (NI-1230)¹⁻⁷

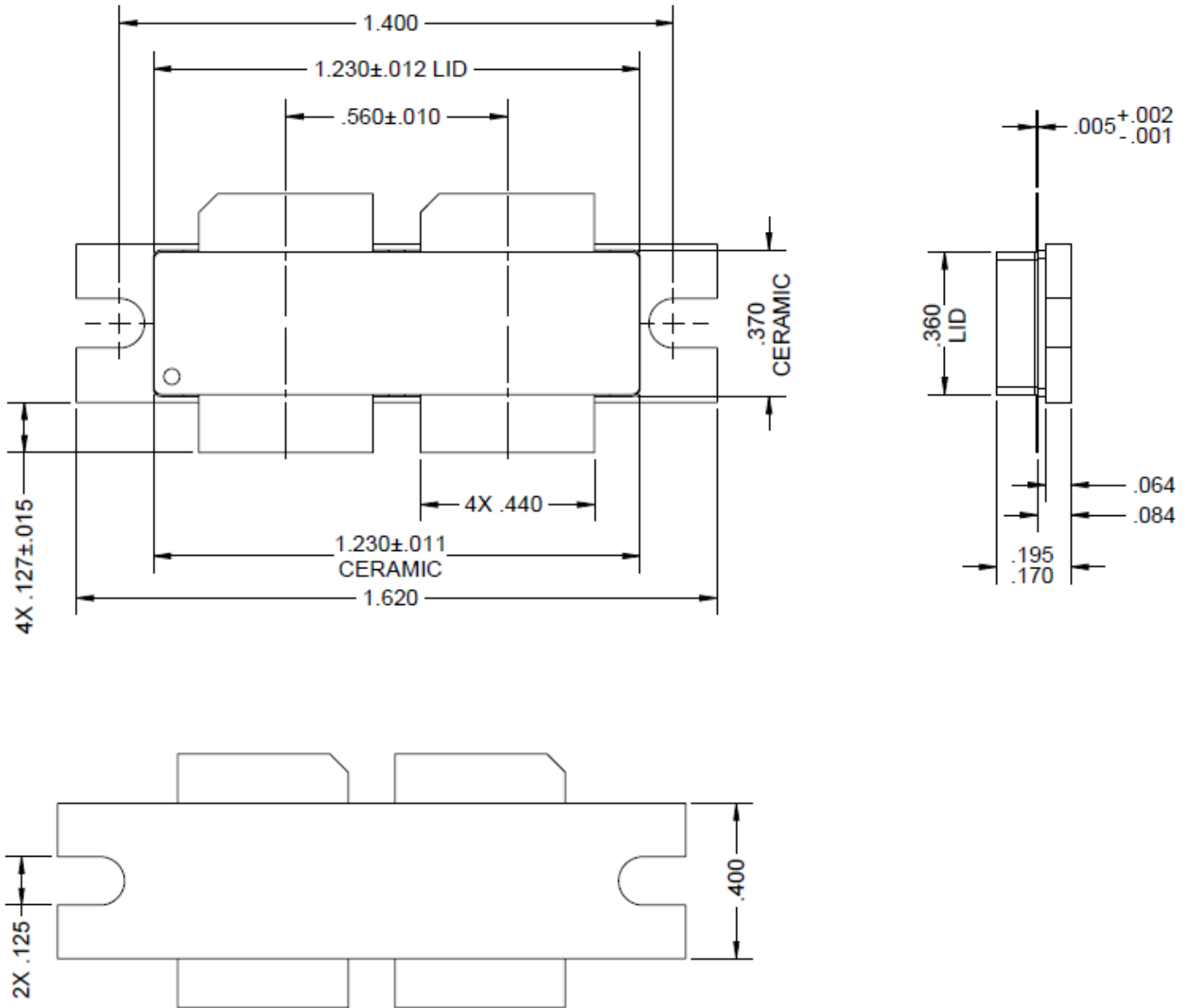

Notes:

1. All dimensions are in inches.
2. Dimension tolerance is ± 0.005 inches, unless noted otherwise.
3. Package base: Ceramic/Metal, Package lid: Ceramic
4. Package Metal base and leads are gold plated
5. Parts are epoxy sealed.
6. Parts meet industry standard NI1230 footprint
7. Body dimensions do not include runout which can be up to 0.020 inches per side.

432 – 442 MHz Application Circuit - Schematic

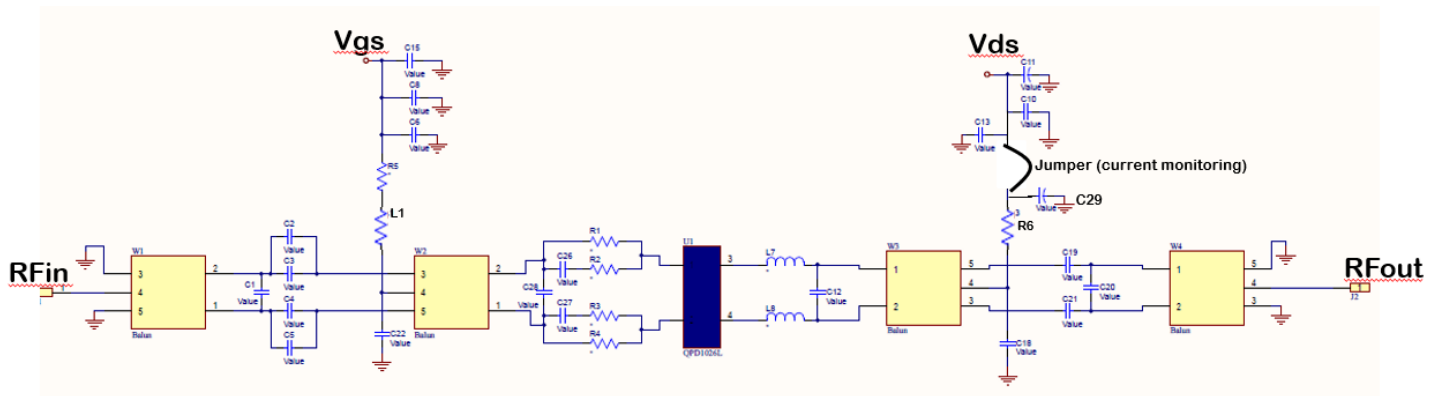

Bias-up Procedure

1. Set V_G to -5 V.
2. Set I_D current limit to 4 A.
3. Apply 65 V V_D .
4. Slowly adjust V_G until I_D is set to 1.5 A.
5. Apply RF.

Bias-down Procedure

1. Turn off RF signal.
2. Turn off V_D
3. Wait 2 seconds to allow drain capacitor to discharge.
4. Turn off V_G

432 – 442 MHz Application Circuit EVB – Layout ¹

Notes:

1. PCB material is RO4350B 0.030" thick, 2 oz. copper each side.

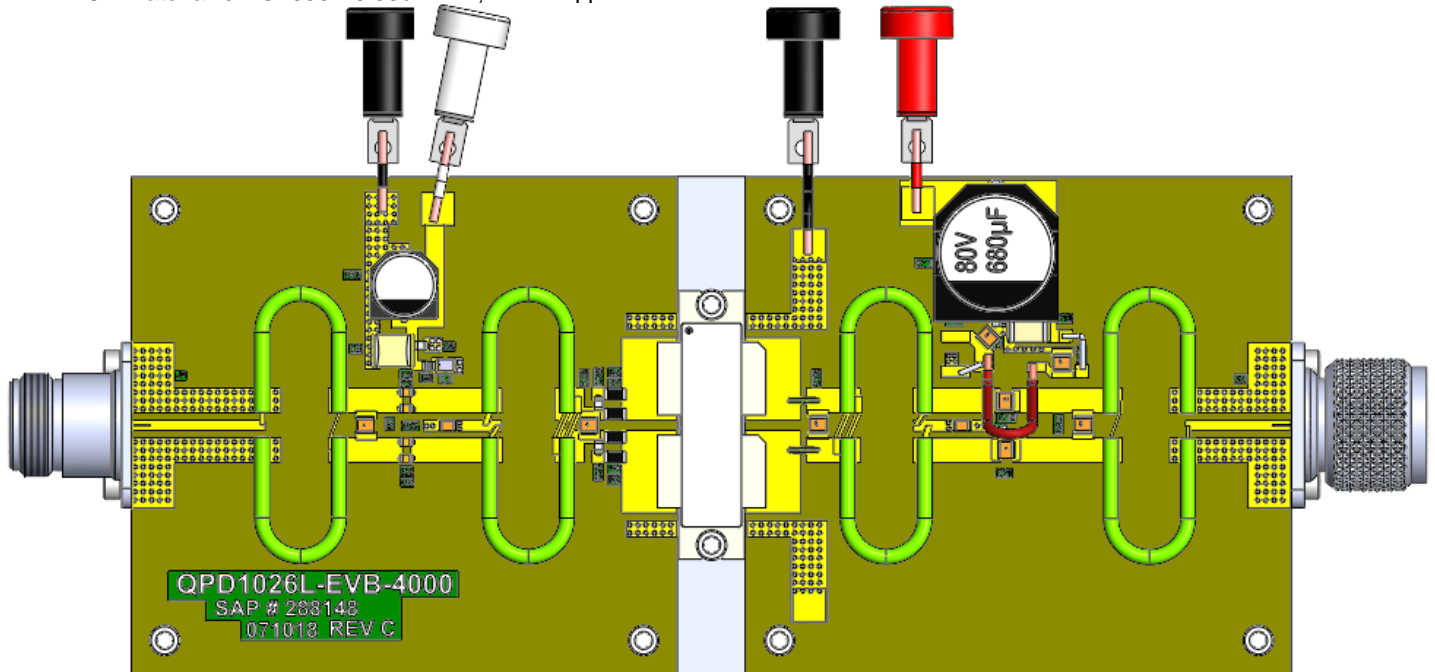

432 – 442 MHz Application Circuit Bill of Material

Reference Design	Value	Qty	Description	Manf. Part Number
Balun 1	50 Ohm	1	Semi-rigid coax, 1.7" shield length	UT-085-50
Balun 2	25 Ohm	1	Semi-rigid coax, 1.7" shield length	UT-090-25
Balun 3	25 Ohm	1	Semi-rigid coax, 1.7" shield length	UT-090-25
Balun 4	50 Ohm	1	Semi-rigid coax, 1.7" shield length	UT-085-50
C1, C20	8.2 pF	2	CAP, 800B, 500V, C0G	800B8R2CT500XT
C2, C3, C4, C5	4.7 pF	4	CAP, 600F, 250V, 0805	600F4R7BT250XT
C6	100 pF	1	CAP, 600F, 250V, C0G	600F101JT250XT
C8	10 uF	1	CAP, 10µF, 10%, 50V, X7S, 2220	C5750X7R1H106K230KB
C10	10 uF	1	CAP, 10uF, 20%, 100V, X7R, 2220	22201C106MAT2A
C11	680 uF	1	CAP, 20%, 80V, Aluminum Electrolytic	MAL215099708E3
C12	22 pF	1	22pF, 800B, 500V, C0G	ATC800B220JW500XT
C13, C29	560 pF	2	560pF, 800B, 500V, C0G	ATC800B561JW100XT
C15	220 uF	1	CAP, 20%, 50V, Aluminum Electrolytic	EMVY500ADA221MJA0G
C19, C21	220 pF	2	220pF, 800B, 500V, C0G	ATC800B221JW200XT
C22, C18	560 pF	2	560pF 800B, vertical placement	ATC800B561JW100XT
C26, C27	56 pF	2	CAP, 56pF, 5%, 250V, C0G, 0805	600F560JT250XT
C28	15 pF	1	CAP, 15pF, 5%, 500V, C0G, ATC-B	800B150JT500XT
R1, R4	5.1 Ohm	2	RES, 5.1 OHM, 1%, 1/4W, SMT, 1206	CRCW12065R10FKEA
R2, R3	0.5 Ohm	2	0.5 ohm, 1%, 1/2W 1206	CSR1206FTR500
R5, R6	0 Ohm	2	0 OHM SMT, 1206	CSR1206FTR00
L1	0 Ohm	1	0 OHM SMT, 1206	CSR1206FTR00
L7, L8	-	2	18 AWG wire, 6 mm long bent at 3 mm	-

Power Driveup Performance over Temperatures of 432 – 442 MHz EVB ¹

Notes:

1. Test Conditions: $V_D = 65\text{ V}$, $I_{DQ} = 1.5\text{ A}$, 500 us Pulse Width, 5% Duty Cycle.

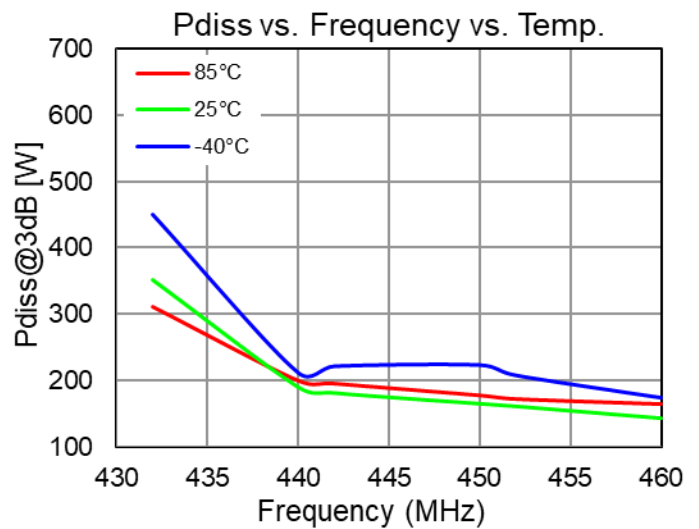
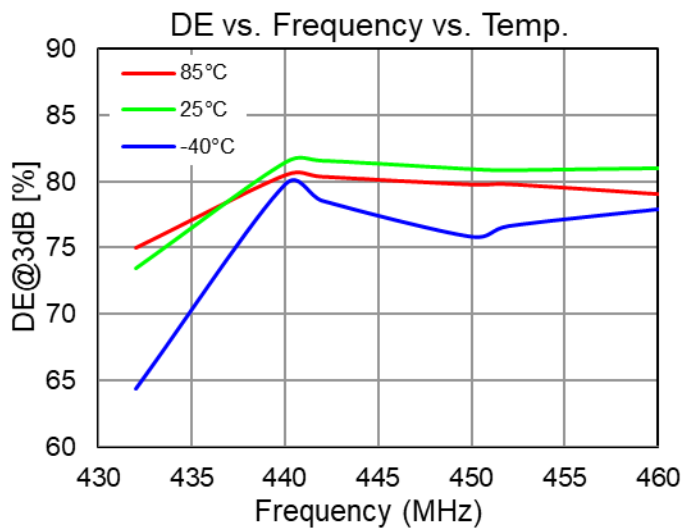
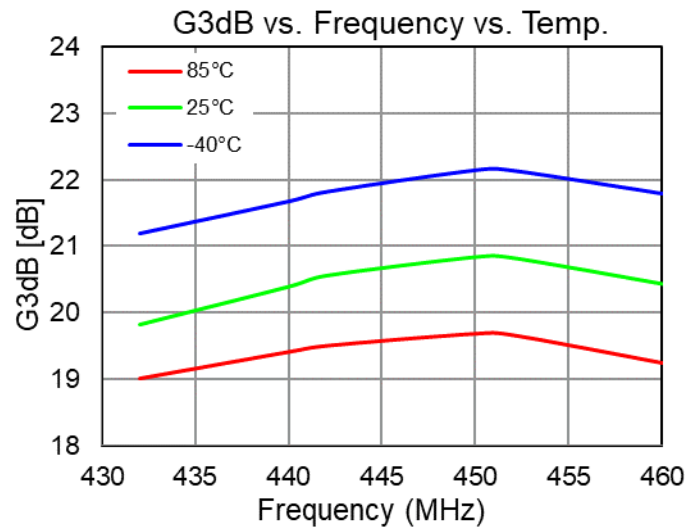
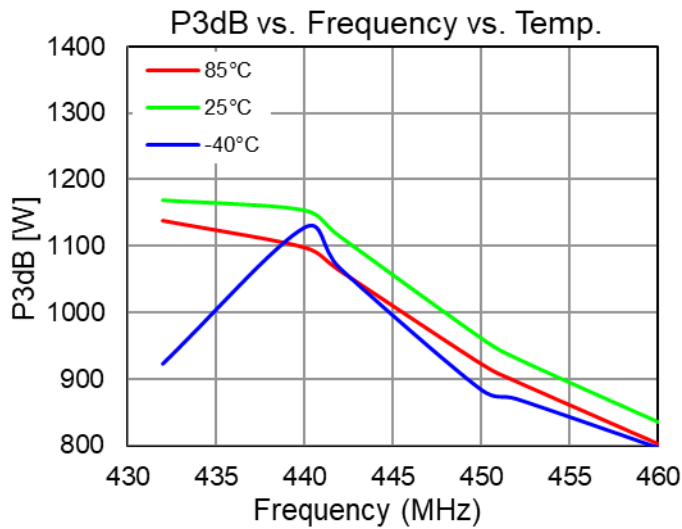

Power Driveup Performance at 25°C of 432 – 442 MHz EVB ¹

Notes:

1. Test Conditions: $V_D = 65\text{ V}$, $I_{DQ} = 1.5\text{ A}$, 500 us Pulse Width, 5% Duty Cycle.

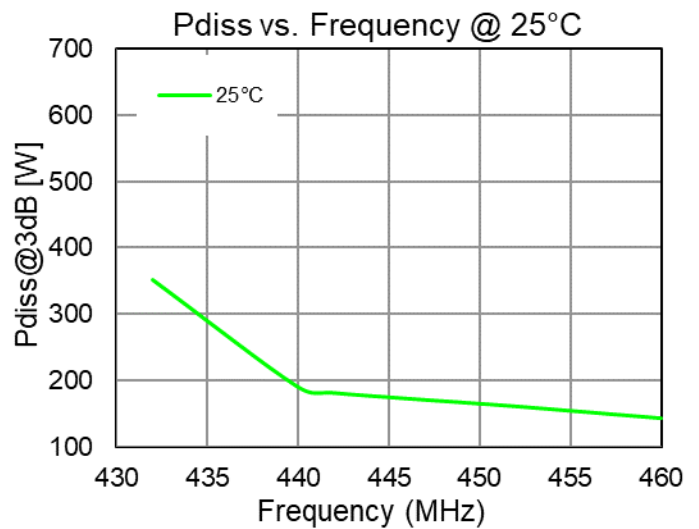
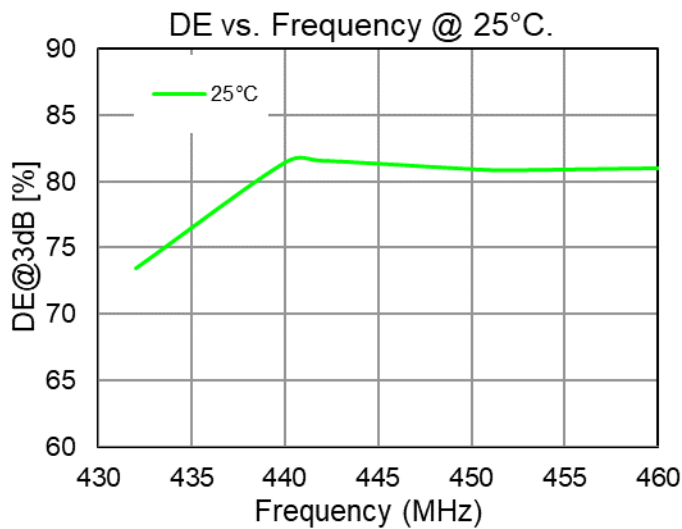
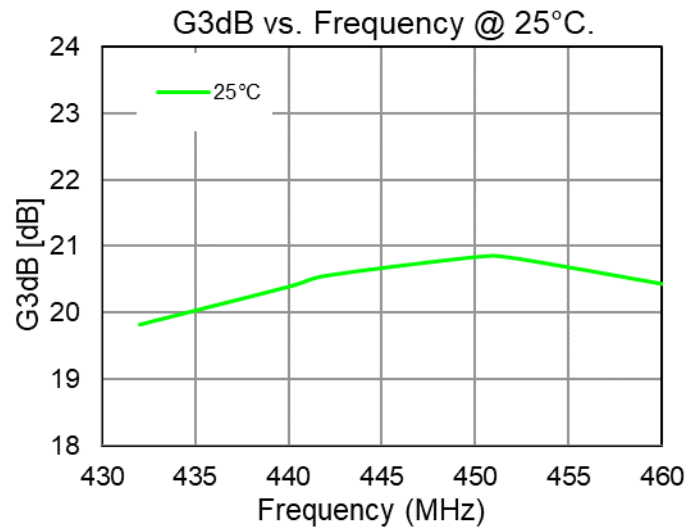
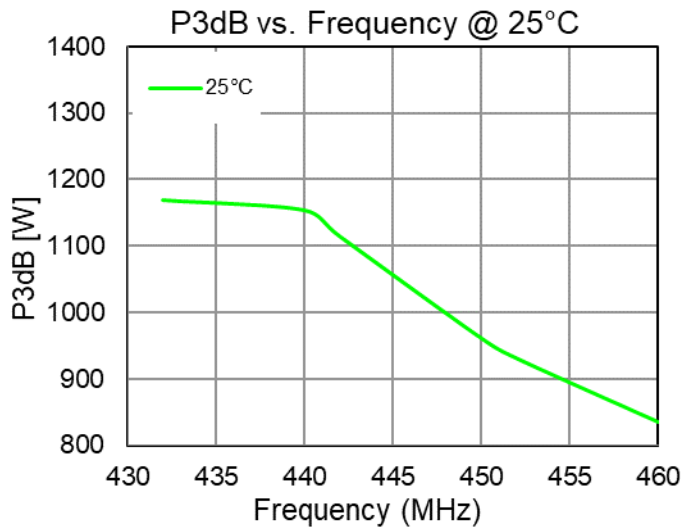

Recommended Solder Temperature Profile

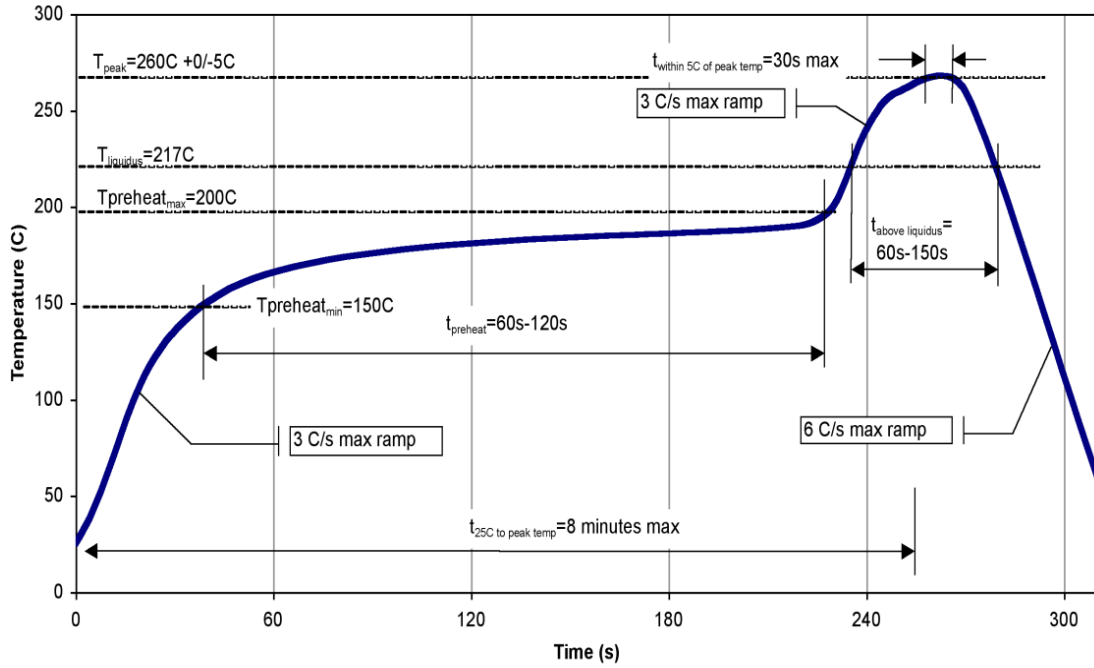

Handling Precautions

Parameter	Rating	Standard
ESD – Human Body Model (HBM)	TBD	JEDEC JS-001
ESD – Charged Device Model (CDM)	TBD	JEDEC JS-002
MSL – Moisture Sensitivity Level	MSL3	JESD J-STD-020 (260°C Convection reflow)



Caution!
ESD-Sensitive Device

Solderability

Compatible with both lead-free (260°C max. reflow temp.) and tin/lead (245°C max. reflow temp.) soldering processes. Solder profiles available upon request.

Contact plating: NiAu. Au thickness is 100micro-inches minimum.

RoHS Compliance

This part is compliant with 2011/65/EU RoHS directive (Restrictions on the Use of Certain Hazardous Substances in Electrical and Electronic Equipment) as amended by Directive 2015/863/EU.

This product also has the following attributes:

- Halogen Free (Chlorine, Bromine)
- Antimony Free
- TBBP-A (C₁₅H₁₂Br₄O₂) Free
- PFOS Free
- SVHC Free

Contact Information

For the latest specifications, additional product information, worldwide sales and distribution locations, and information about Qorvo:

Web: www.qorvo.com

Tel: +1.844.890.8163

Email: info-sales@qorvo.com

For technical questions and application information:

Email: info-products@qorvo.com

Important Notice

The information contained herein is believed to be reliable; however, Qorvo makes no warranties regarding the information contained herein and assumes no responsibility or liability whatsoever for the use of the information contained herein. All information contained herein is subject to change without notice. Customers should obtain and verify the latest relevant information before placing orders for Qorvo products. The information contained herein or any use of such information does not grant, explicitly or implicitly, to any party any patent rights, licenses, or any other intellectual property rights, whether with regard to such information itself or anything described by such information. **THIS INFORMATION DOES NOT CONSTITUTE A WARRANTY WITH RESPECT TO THE PRODUCTS DESCRIBED HEREIN, AND QORVO HEREBY DISCLAIMS ANY AND ALL WARRANTIES WITH RESPECT TO SUCH PRODUCTS WHETHER EXPRESS OR IMPLIED BY LAW, COURSE OF DEALING, COURSE OF PERFORMANCE, USAGE OF TRADE OR OTHERWISE, INCLUDING THE IMPLIED WARRANTIES OF MERCHANTABILITY AND FITNESS FOR A PARTICULAR PURPOSE.**

Without limiting the generality of the foregoing, Qorvo products are not warranted or authorized for use as critical components in medical, life-saving, or life-sustaining applications, or other applications where a failure would reasonably be expected to cause severe personal injury or death.

Copyright 2018 © Qorvo, Inc. | Qorvo is a registered trademark of Qorvo, Inc.