

## Product Overview

The QPD1018 is a 500W ( $P_{3dB}$ ) internally matched discrete GaN on SiC HEMT which operates from 2.7 to 3.1 GHz and a 50V supply rail. The device is GaN IMFET fully matched to 50  $\Omega$  in an industry standard air cavity package and is ideally suited for military radar.

ROHS compliant.

Evaluation boards are available upon request.



17.40 x 24.00 x 4.31 mm

## Key Features

- Frequency: 2.7 to 3.1 GHz
- Output Power ( $P_{3dB}$ )<sup>1</sup>: 575 W
- Linear Gain<sup>1</sup>: 17.7 dB
- Typical PAE<sub>3dB</sub><sup>1</sup>: 67.9%
- Operating Voltage: 50 V
- Low thermal resistance package
- Pulse capable

Notes:

1. @ 2.9 GHz

## Functional Block Diagram

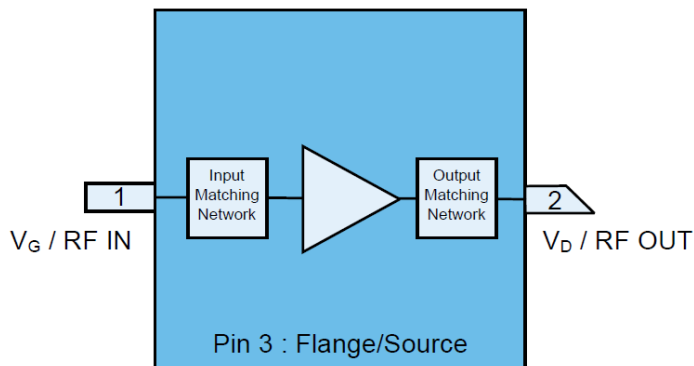

## Applications

- Military Radar
- Civilian Radar
- Test Instrumentation

## Ordering Information

Part Number	Description
QPD1018	Tray of 18 QPD1018
QPD1018EVB	2.7 – 3.1 GHz EVB

### Absolute Maximum Ratings<sup>1</sup>

Parameter	Rating	Units
Breakdown Voltage ( $V_{DG}$ )	+145	V
Gate Voltage ( $V_G$ )	-7 to +2	V
Drain Current ( $I_D$ )	20	A
Gate Current ( $I_G$ )	See page 4	mA
Power Dissipation ( $P_D$ ) <sup>2</sup>	522	W
RF Input Power ( $RF_{IN}$ ) <sup>3</sup>	+49	dBm
Mounting Temperature (30 seconds)	320	°C
Storage Temperature	-65 to +150	°C

Notes:

- Operation of this device outside the parameter ranges given above may cause permanent damage.
- Pulsed CW: Pulse Width = 100 us, Duty Cycle = 10% @ 85 °C
- Pulsed CW: Pulse Width = 100 us, Duty Cycle = 10% @ 2.9 GHz, 25 °C

### Recommended Operating Conditions<sup>1</sup>

Parameter	Min	TYP	Max	Units
Operating Temperature	-40	+25	+85	°C
Drain Voltage ( $V_D$ )	+28	+50	+55	V
Drain Bias Current ( $I_{DQ}$ )	-	750	-	mA
Drain Current ( $I_D$ )	-	15	-	A
Gate Voltage ( $V_G$ ) <sup>3</sup>	-	-2.8	-	V
Power Dissipation ( $P_D$ ) <sup>2</sup>	-	-	472	W

Notes:

- Electrical performance is measured under conditions noted in the electrical specifications table. Specifications are not guaranteed over all recommended operating conditions.
- Pulsed CW: Pulse Width = 100 us, Duty Cycle = 10%  
Package base at 85°C
- To be adjusted to desired  $I_{DQ}$

### Pulsed Characterization – Load Pull Performance – Power Tuned<sup>1</sup>

Parameters	Typical Values			Units
	2.7	2.9	3.1	
Frequency	2.7	2.9	3.1	GHz
Linear Gain ( $G_{LIN}$ )	16.1	16.4	14.6	dB
Output Power at 3dB Compression ( $P_{3dB}$ )	57.7	57.6	57.5	dBm
Power-Added-Efficiency at 3dB Compression ( $PAE_{3dB}$ )	59.1	56.6	56.1	%
Gain at 3dB Compression ( $G_{3dB}$ )	13.1	13.4	11.6	dB

Notes:

- Test conditions unless otherwise noted:  $V_D = +50$  V,  $I_{DQ} = 750$  mA,  $T_A = +25$  °C, Pulse Width = 100 us, Duty Cycle = 10%

### Pulsed Characterization – Load Pull Performance – Efficiency Tuned<sup>1</sup>

Parameters	Typical Values			Units
	2.7	2.9	3.1	
Frequency	2.7	2.9	3.1	GHz
Linear Gain ( $G_{LIN}$ )	16.9	17.7	15.8	dB
Output Power at 3dB Compression ( $P_{3dB}$ )	56.5	56.1	55.8	dBm
Power-Added-Efficiency at 3dB Compression ( $PAE_{3dB}$ )	68.6	67.9	65.2	%
Gain at 3dB Compression ( $G_{3dB}$ )	13.9	14.7	12.8	dB

Notes:

- Test conditions unless otherwise noted:  $V_D = +50$  V,  $I_{DQ} = 750$  mA,  $T_A = +25$  °C, Pulse Width = 100 us, Duty Cycle = 10%

## RF Characterization – 2.7 – 3.1 GHz EVB Performance at 2.7 GHz<sup>1</sup>

Parameters	Typical Values			Units
Linear Gain ( $G_{LIN}$ )	-	16.6	-	dB
Output Power at 3dB Compression ( $P_{3dB}$ )	-	56.7	-	dBm
Power-Added-Efficiency at 3dB Compression ( $PAE_{3dB}$ )	-	64.4	-	%
Gain at 3dB Compression ( $G_{3dB}$ )	-	13.6	-	dB

Notes:

- Test conditions unless otherwise noted:  $V_D = +50$  V,  $I_{DQ} = 750$  mA,  $T_A = +25$  °C, Pulse Width = 100 us, Duty Cycle = 10%

## RF Characterization – 2.7 – 3.1 GHz EVB Performance at 2.9 GHz<sup>1</sup>

Parameters	Typical Values			Units
Linear Gain ( $G_{LIN}$ )	-	16.8	-	dB
Output Power at 3dB Compression ( $P_{3dB}$ )	-	56.6	-	dBm
Power-Added-Efficiency at 3dB Compression ( $PAE_{3dB}$ )	-	57.1	-	%
Gain at 3dB Compression ( $G_{3dB}$ )	-	13.8	-	dB

Notes:

- Test conditions unless otherwise noted:  $V_D = +50$  V,  $I_{DQ} = 750$  mA,  $T_A = +25$  °C, Pulse Width = 100 us, Duty Cycle = 10%

## RF Characterization – 2.7 – 3.1 GHz EVB Performance at 3.1 GHz<sup>1</sup>

Parameters	Typical Values			Units
Linear Gain ( $G_{LIN}$ )	-	15.4	-	dB
Output Power at 3dB Compression ( $P_{3dB}$ )	-	56.8	-	dBm
Power-Added-Efficiency at 3dB Compression ( $PAE_{3dB}$ )	-	56.0	-	%
Gain at 3dB Compression ( $G_{3dB}$ )	-	12.4	-	dB

Notes:

- Test conditions unless otherwise noted:  $V_D = +50$  V,  $I_{DQ} = 750$  mA,  $T_A = +25$  °C, Pulse Width = 100 us, Duty Cycle = 10%

## RF Characterization – Mismatch Ruggedness at 1.3 GHz<sup>1, 2, 3</sup>

Symbol	Parameter	dB Compression	Typical
VSWR	Impedance Mismatch Ruggedness	3	10:1

Notes:

- Test conditions unless otherwise noted:  $V_D = +50$  V,  $I_{DQ} = 750$  mA,  $T_A = +25$  °C, Pulse Width = 100 us, Duty Cycle = 10%
- Driving input power is determined at pulsed compression under matched condition at EVB output connector.
- No spur detected down to the noise floor of Spectrum Analyzer from 1 – 15 GHz at  $T_A = -40$  °C

**Thermal and Reliability Information – Pulsed**

**Peak IR Surface Temperature vs. Pulse Width**  
**P<sub>diss</sub> = 346 W, Base Temperature @ 85°C**

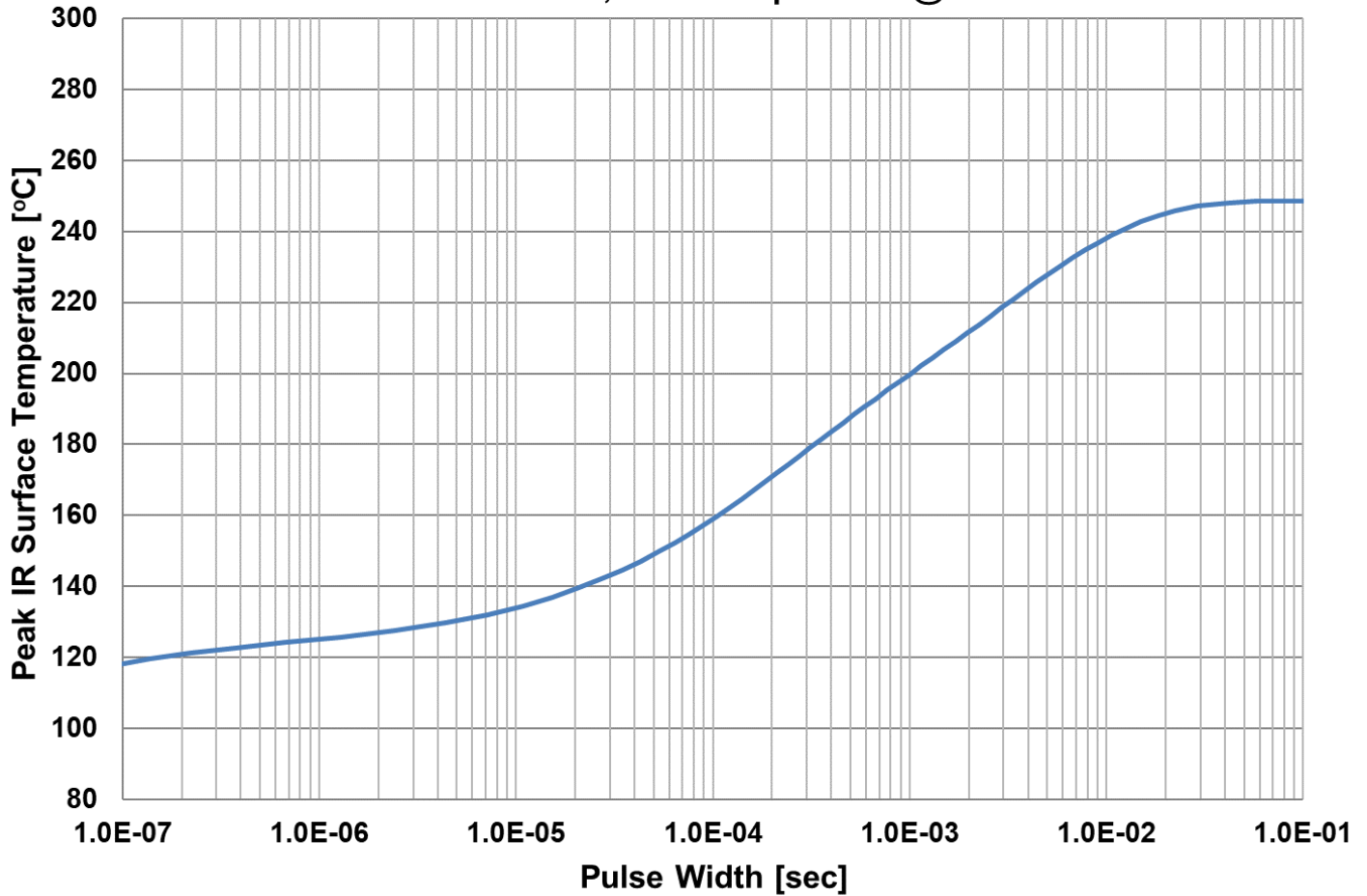

Parameter	Conditions	Values	Units
Thermal Resistance, IR <sup>1</sup> ( $\theta_{JC}$ )	85 °C back side temperature	0.33	°C/W
Peak IR Surface Temperature <sup>1</sup> ( $T_{CH}$ )	346 W P <sub>D</sub> , Pulse Width = 1 ms, Duty Cycle = 10%	200	°C

Notes:

1. Refer to the following document [GaN Device Channel Temperature, Thermal Resistance, and Reliability Estimates](#)

Load Pull Contours<sup>1, 2, 3</sup>

Notes:

1.  $V_D = 50\text{ V}$ ,  $I_{DQ} = 750\text{ mA}$ , Pulse Width = 100 us. Duty Cycle = 10%. Performance is at 3 dB gain compression referenced to peak gain.
2. See page 11 for load-pull and source-pull reference planes. 50  $\Omega$  load-pull TRL fixtures are built with 20 mils RO4350B material.
3. NaN means the impedance are either undefined or varying in load-pull system.

2.7GHz, Load-pull

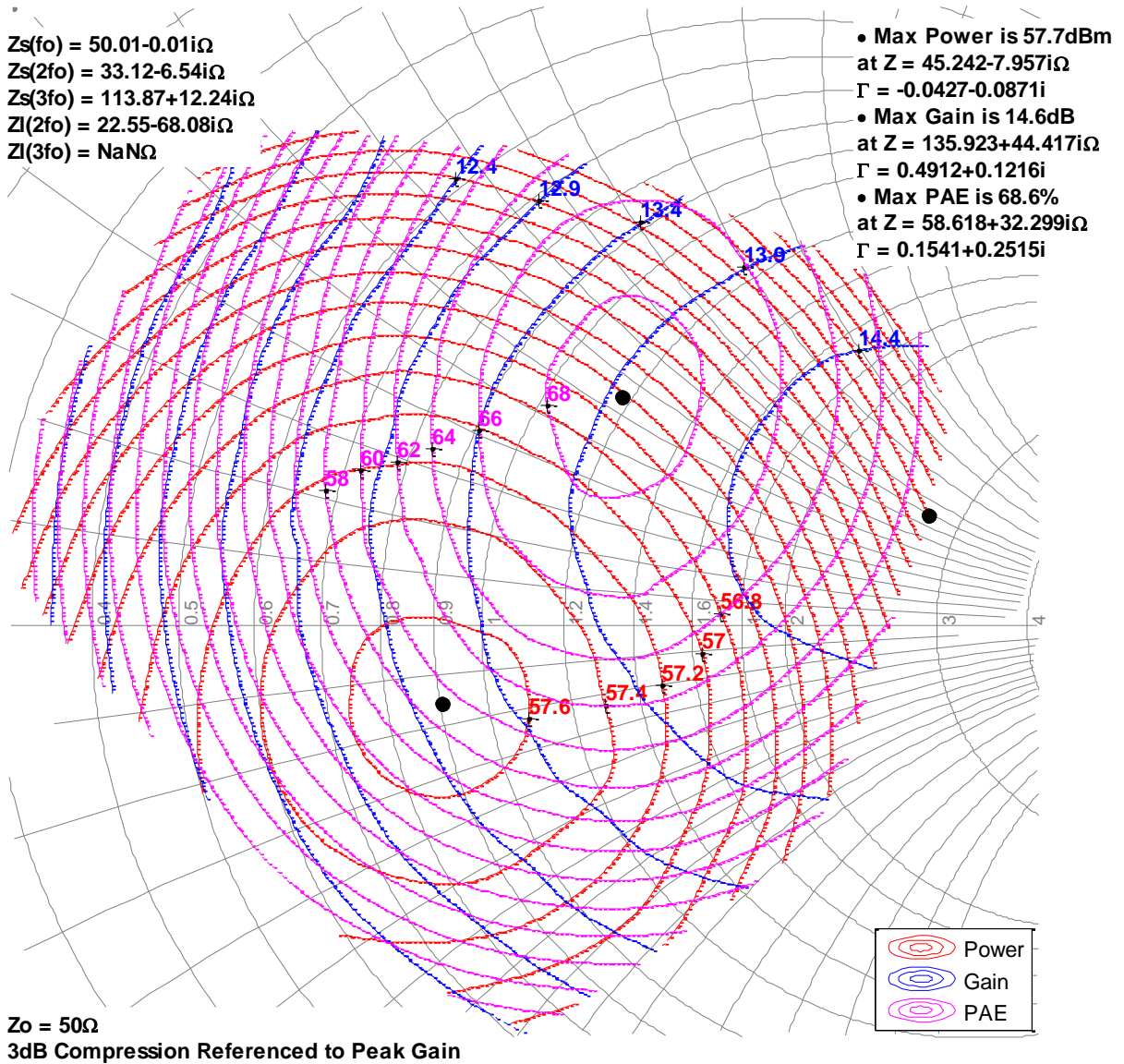

## Load Pull Contours<sup>1, 2, 3</sup>

**Notes:**

1.  $V_D = 50\text{ V}$ ,  $I_{DQ} = 750\text{ mA}$ , Pulse Width = 100 us. Duty Cycle = 10%. Performance is at 3 dB gain compression referenced to peak gain.
2. See page 11 for load-pull and source-pull reference planes. 50  $\Omega$  load-pull TRL fixtures are built with 20 mils RO4350B material.
3. NaN means the impedance are either undefined or varying in load-pull system.

### 2.9GHz, Load-pull

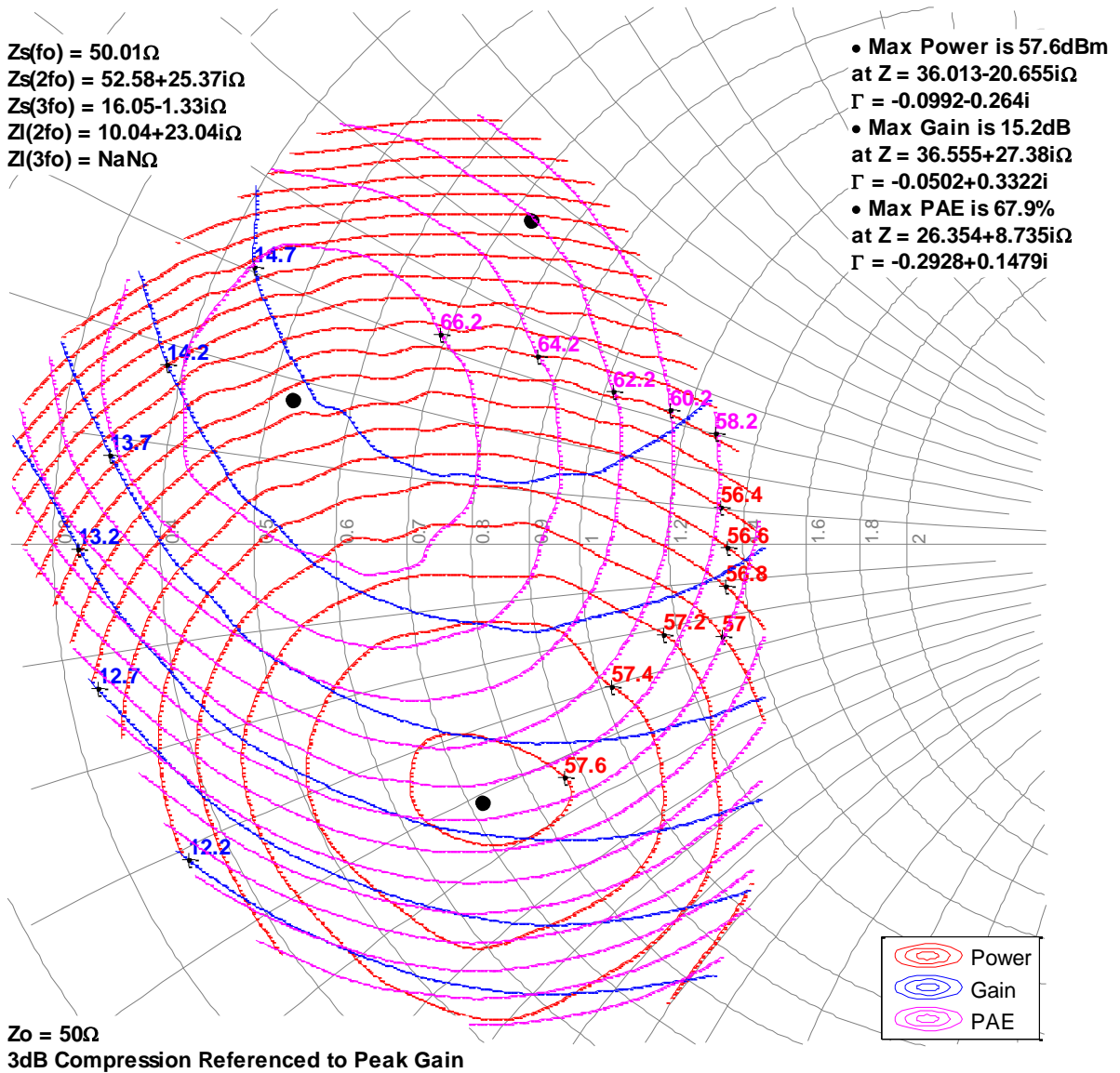

Load Pull Contours<sup>1, 2, 3</sup>

Notes:

1.  $V_D = 50\text{ V}$ ,  $I_{DQ} = 750\text{ mA}$ , Pulse Width = 100 us. Duty Cycle = 10%. Performance is at 3 dB gain compression referenced to peak gain.
2. See page 11 for load-pull and source-pull reference planes. 50  $\Omega$  load-pull TRL fixtures are built with 20 mils RO4350B material.
3. NaN means the impedance are either undefined or varying in load-pull system.

3.1GHz, Load-pull

$Z_s(f_0) = 49.99+0.01i\Omega$   
 $Z_s(2f_0) = 68.83-20.58i\Omega$   
 $Z_s(3f_0) = 245.31-140.94i\Omega$   
 $Z_l(2f_0) = 123.01+32.14i\Omega$   
 $Z_l(3f_0) = \text{NaN}\Omega$

- Max Power is 57.5dBm at  $Z = 51.87-29.303i\Omega$   
 $\Gamma = 0.0934-0.2608i$
- Max Gain is 12.9dB at  $Z = 25.713+5.863i\Omega$   
 $\Gamma = -0.3129+0.1017i$
- Max PAE is 65.2% at  $Z = 27.066-8.387i\Omega$   
 $\Gamma = -0.2824-0.1396i$

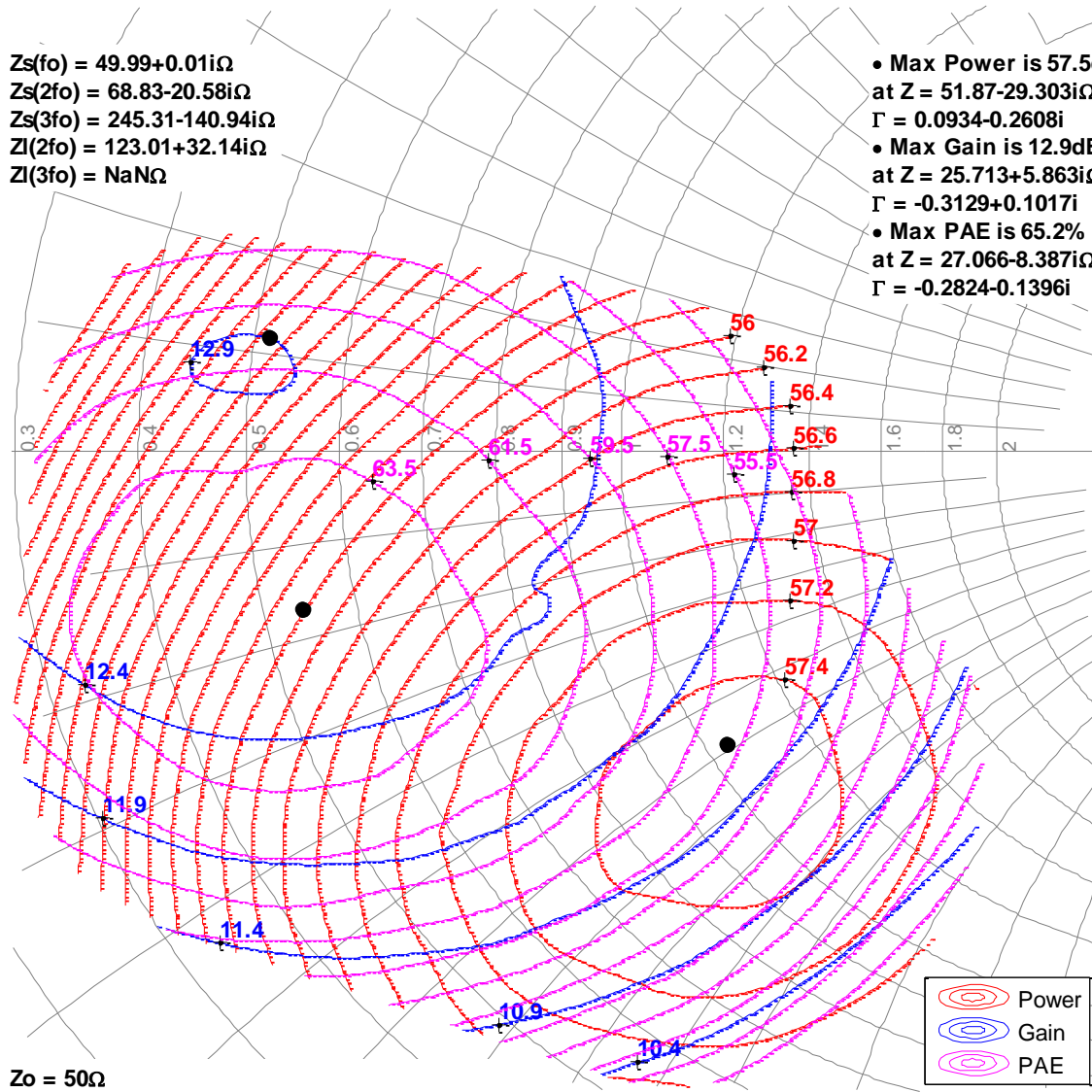

$Z_0 = 50\Omega$   
 3dB Compression Referenced to Peak Gain

## Typical Performance – Load-Pull Drive-up<sup>1, 2</sup>

Notes:

1.  $V_D = 50\text{ V}$ ,  $I_{DQ} = 750\text{ mA}$ , Pulse Width = 100 us, Duty Cycle = 10%,  $T_A = 25\text{ }^\circ\text{C}$
2. See page 11 for load-pull and source-pull reference planes where the performance was measured.

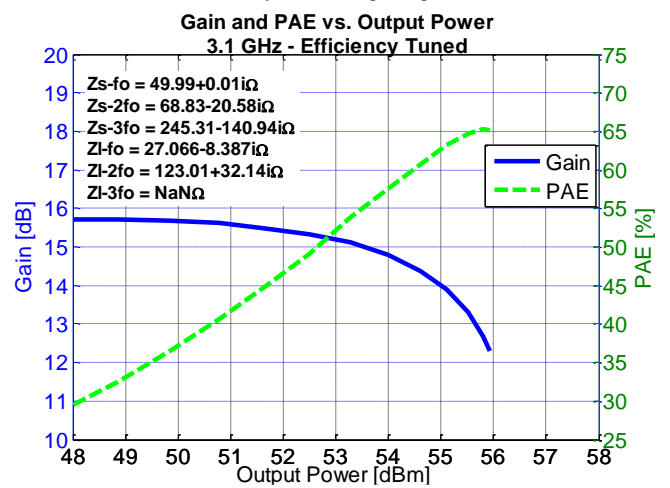
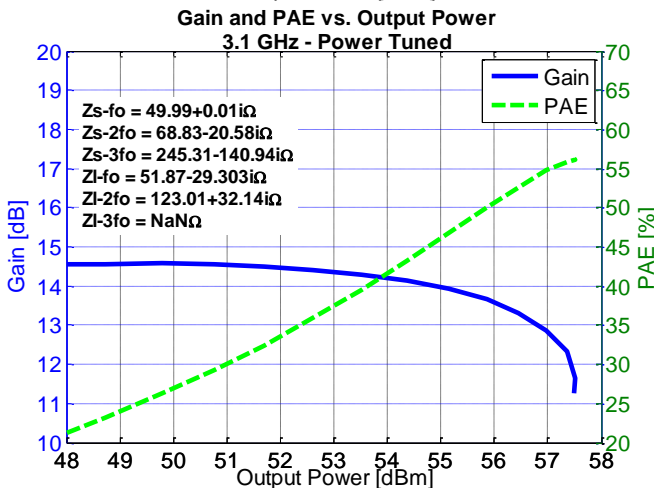
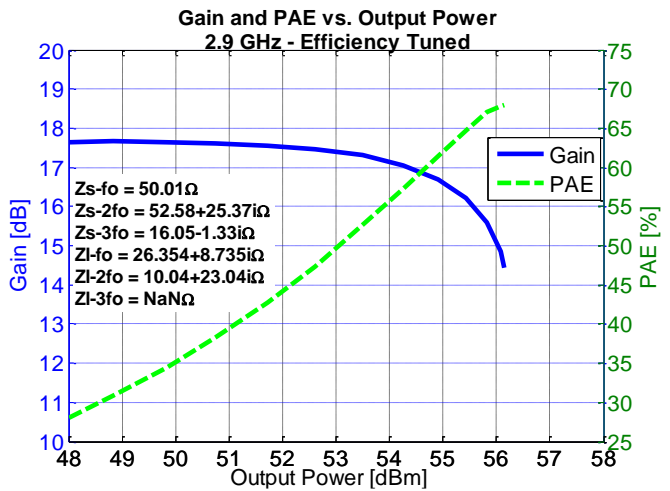
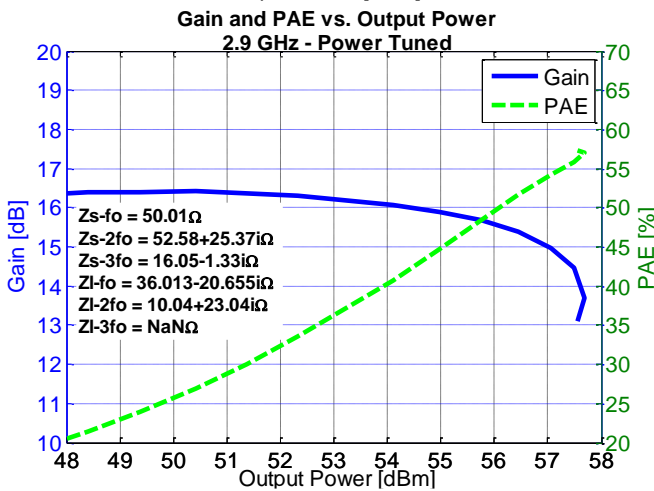
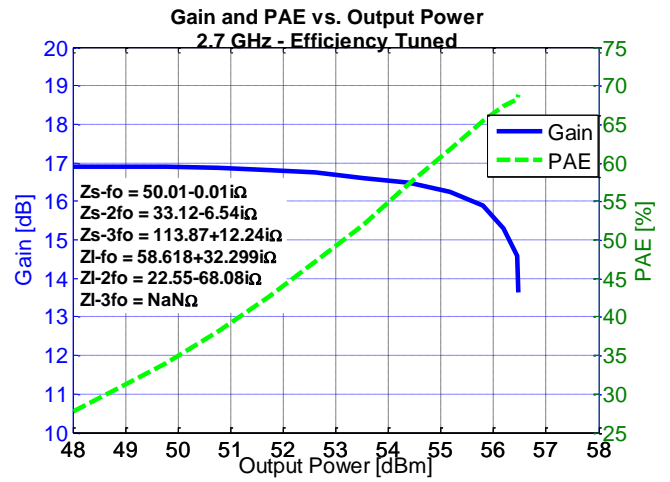
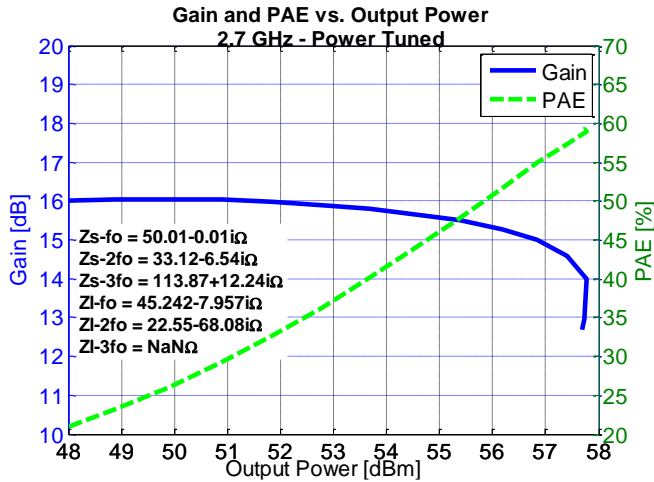



**Power Drive-Up Performance Over Temperatures of 2.7 – 3.1 GHz EVB<sup>1,2</sup>**

Notes:

1.  $V_D = 50\text{ V}$ ,  $I_{DQ} = 750\text{ mA}$ , Pulse Width = 100 us, Duty Cycle = 10%
2. Performance shown is at EVB connectors reference plane.

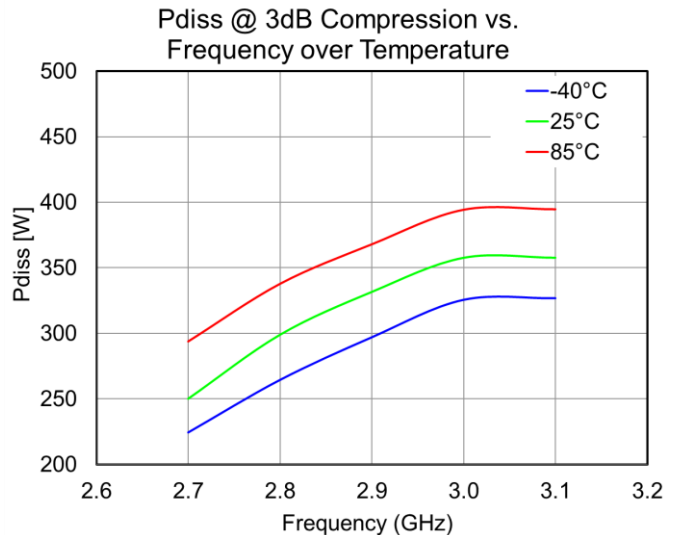
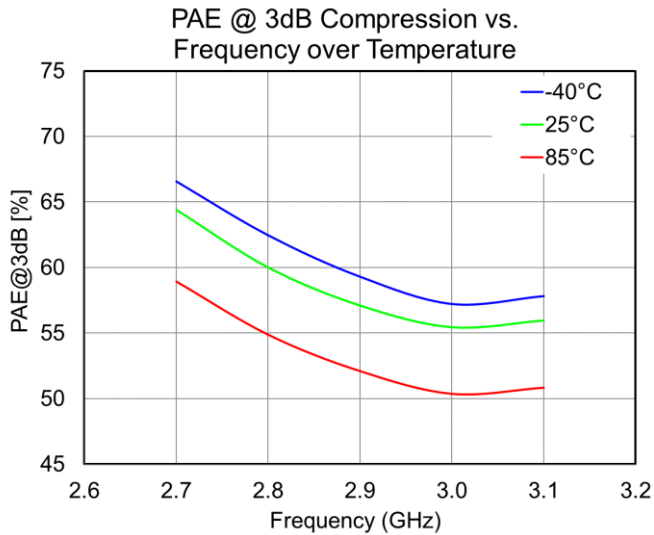
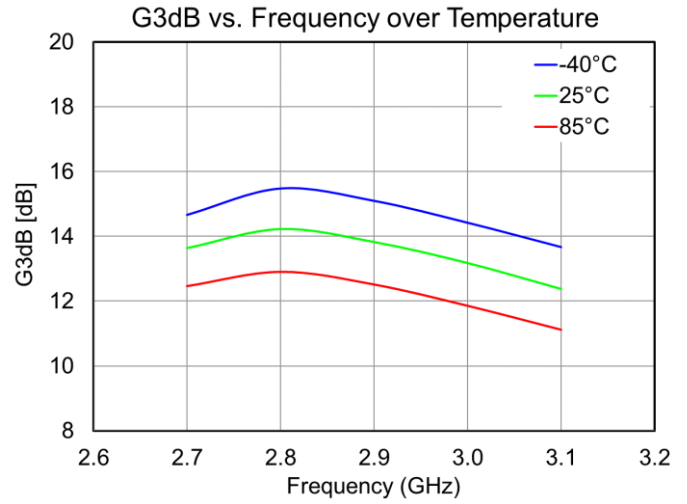
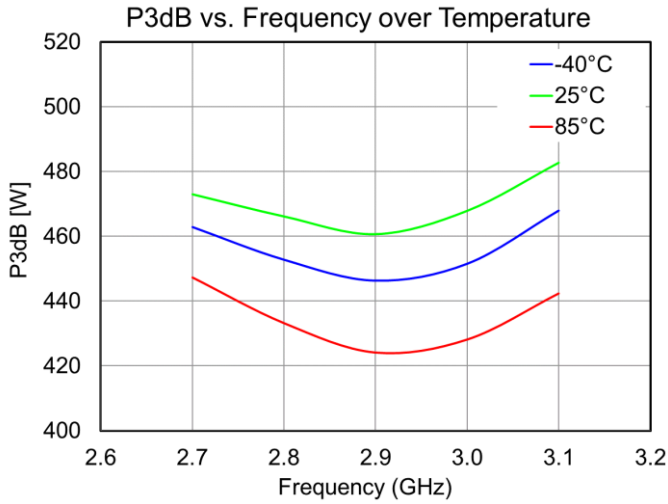

## Power Drive-Up Performance at 25 °C of 2.7 – 3.1 GHz EVB<sup>1</sup>

**Notes:**

1.  $V_D = 50\text{ V}$ ,  $I_{DQ} = 750\text{ mA}$ , Pulse Width = 100 us, Duty Cycle = 10%,  $T_A = 25\text{ °C}$
2. Performance shown is at EVB connectors reference plane.

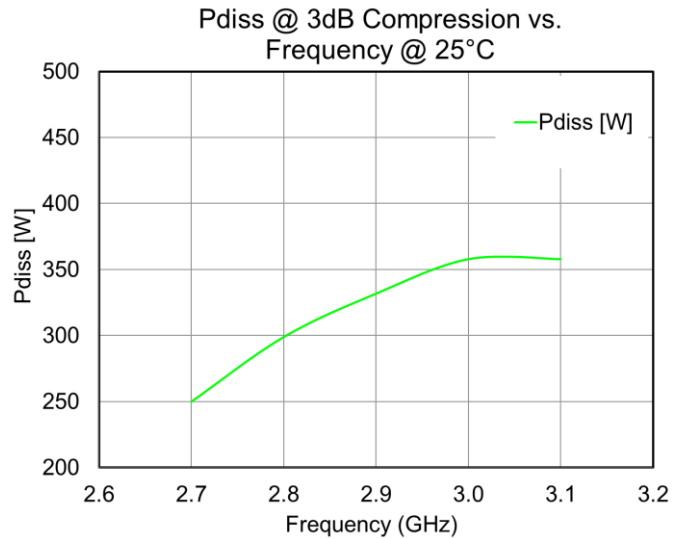
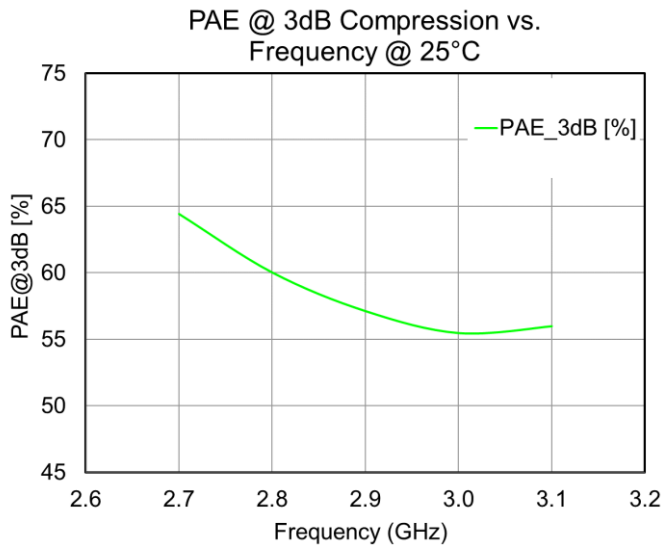
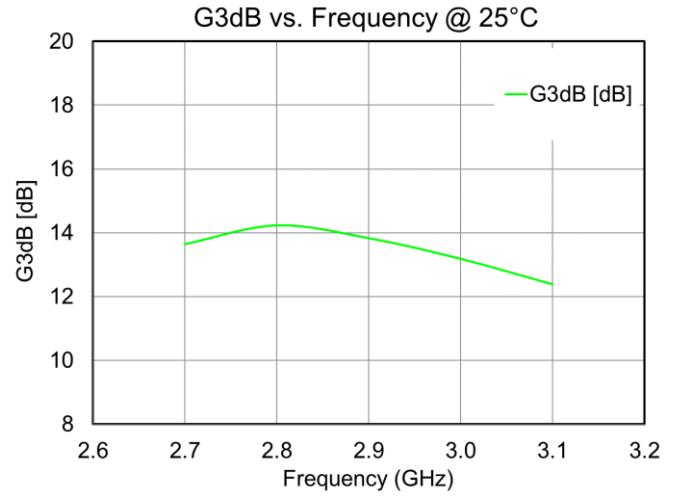
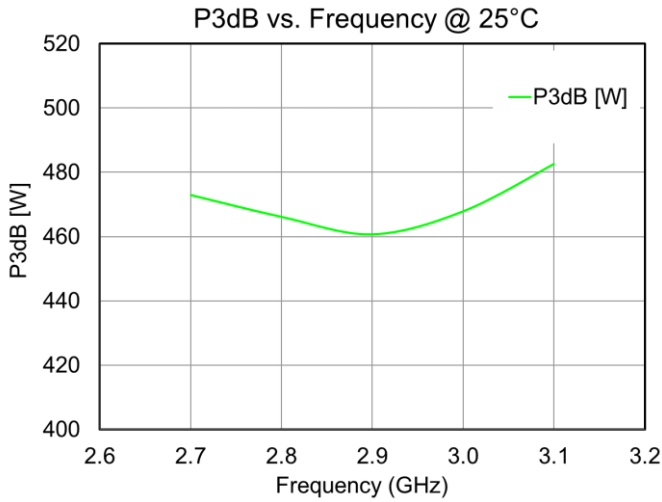

### Pin Configuration and Package Marking<sup>1</sup>

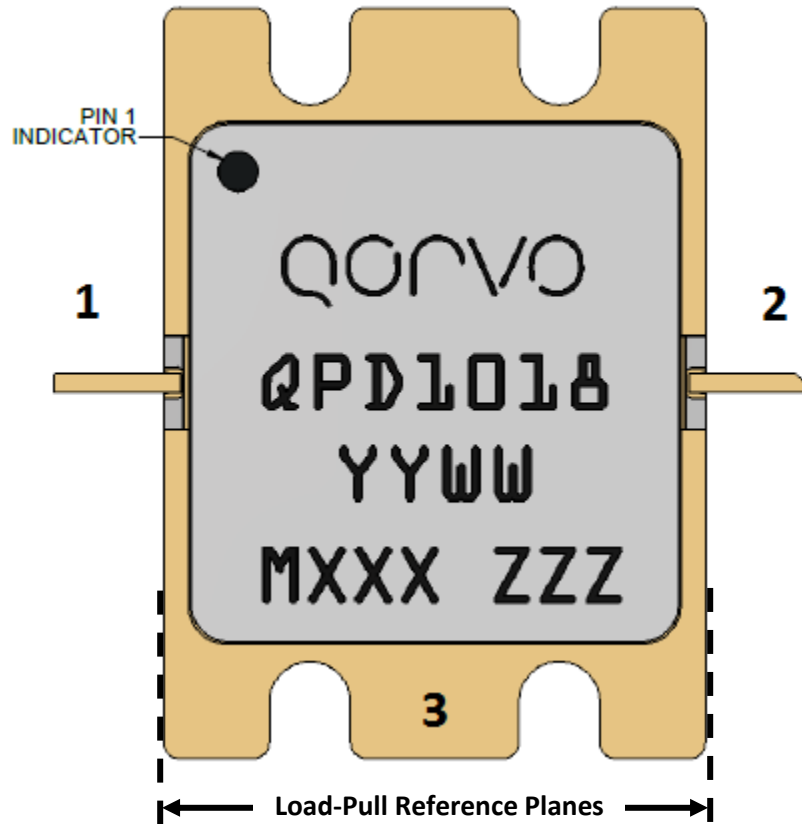

Pin	Symbol	Description
1	$V_G / RF_{IN}$	Gate Voltage / RF Input
2	$V_D / RF_{OUT}$	Drain Voltage / RF Output
3	GND	Package base/ Ground

**Notes:**

- The QPD1018 will be marked with the “QPD1018” designator and a lot code marked below the part designator. The “YY” represents the last two digits of the calendar year the part was manufactured, the “WW” is the work week of the assembly lot start, the “MXXX” is the production lot number. “ZZZ” is the unique serial number.

## Assembly Notes

---

1. Carefully clean the PC board and package leads with alcohol. Allow it to dry fully.
2. To improve the thermal and RF performance, Qorvo recommends attaching a heat sink to the bottom of the PCB and apply thermal compound (Arctic Silver 5 recommended or 4 mil indium shim between the heat sink and the package).
3. (The following is for *information only*. There are many variables in a second level assembly that Qorvo does not control, so Qorvo does not recommend an absolute torque value.) Use screws to attach the component to the heat sink. A suggested torque value is 16 in-oz. for a 0-80 screw. Start with screws finger tight, then torque to 8 in-oz., then torque to final value. Use the following tightening pattern.

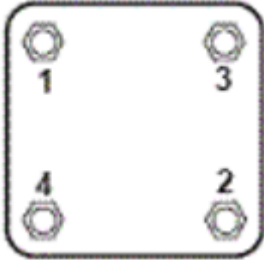

4. Apply no-flux solder to each pin of the QPD1018. The component leads should be manually soldered, and the package cannot be subjected to conventional reflow processes. The use of no-clean solder to avoid washing after soldering is recommended.

## Package Dimensions<sup>1, 2, 3, 4</sup>

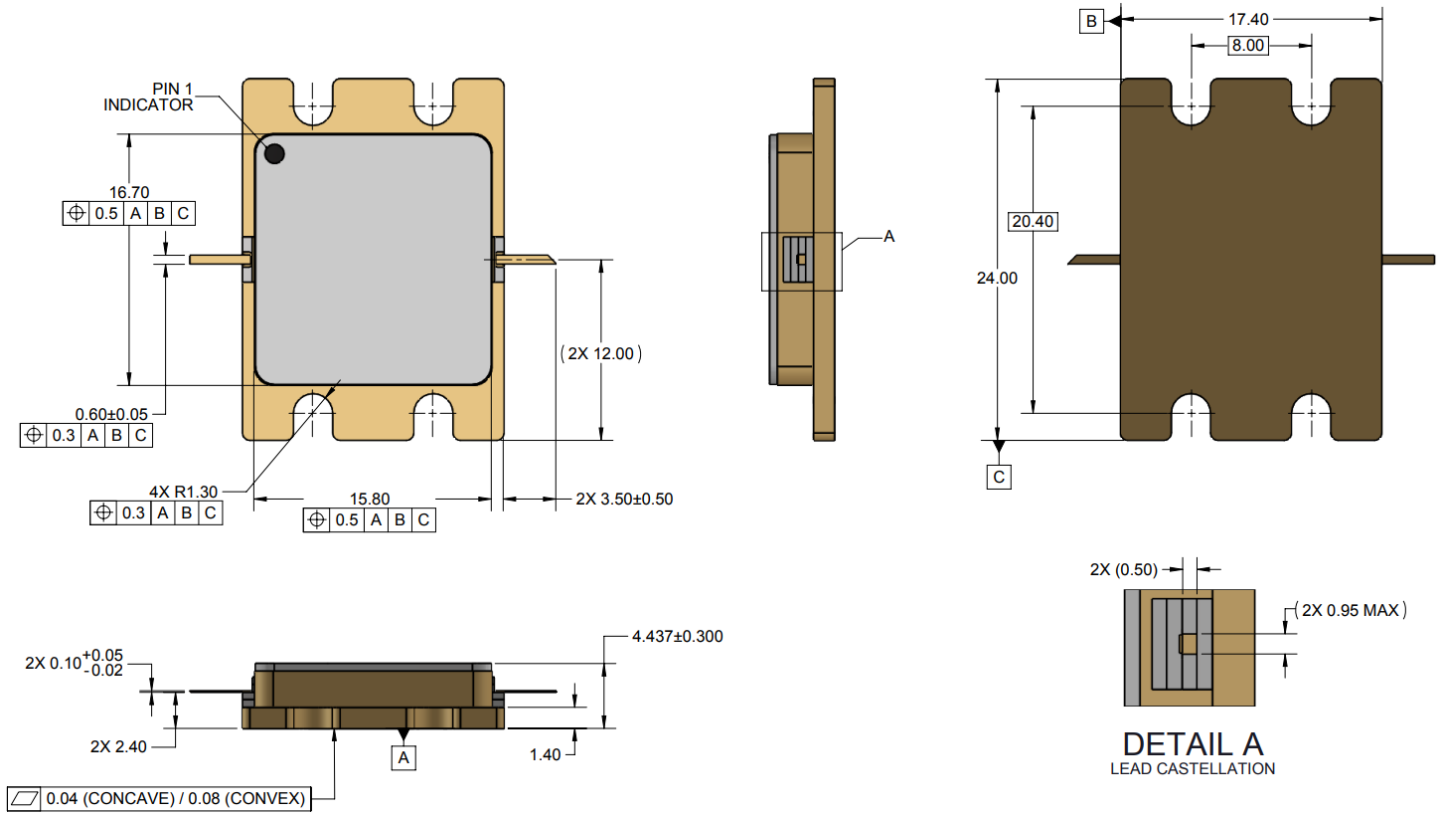

### Notes:

1. All dimensions are in mm. Unless otherwise noted, the tolerance is  $\pm 0.15$  mm
2. Package is an all metal design with ceramic lid and feed thru's.
3. Package is Ni/Au plated.
4. Package is epoxy sealed.
5. For instruction to mount the part, please refer to application note "[RF565 Package Mounting, Mechanical Mounting and PCB Considerations.](#)"

## Schematic – 1.2 – 1.4 GHz EVB

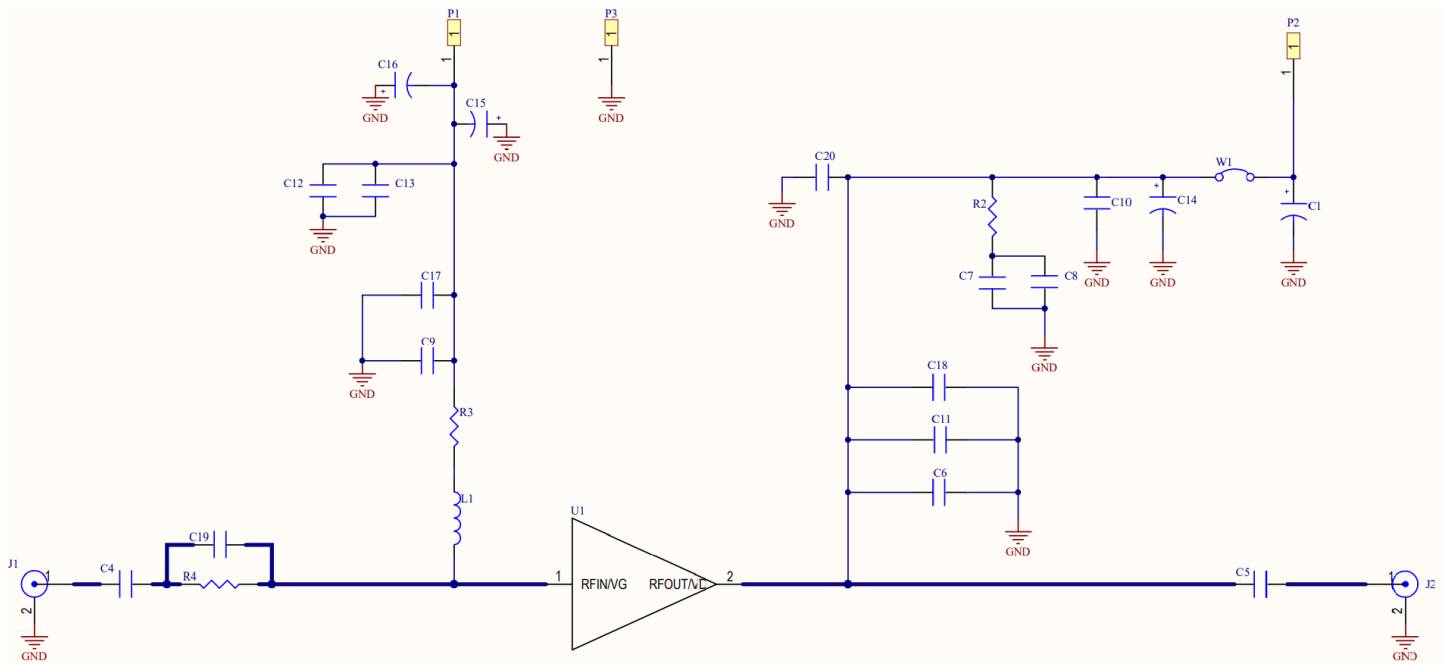

### Bias-up Procedure

1. Set  $V_G$  to -6 V
2. Set  $I_D$  current limit to 1 A.
3. Set  $V_D$  to 50 V.
4. Slowly adjust  $V_G$  until  $I_D$  is set to 750 mA.
5. Set  $I_D$  current limit to 2 A.
6. Apply RF.

### Bias-down Procedure

1. Turn off RF signal.
2. Turn off  $V_D$ .
3. Wait 2 seconds to allow drain capacitor to discharge
4. Turn off  $V_G$

## 2.7 – 3.1 GHz EVB<sup>1</sup>

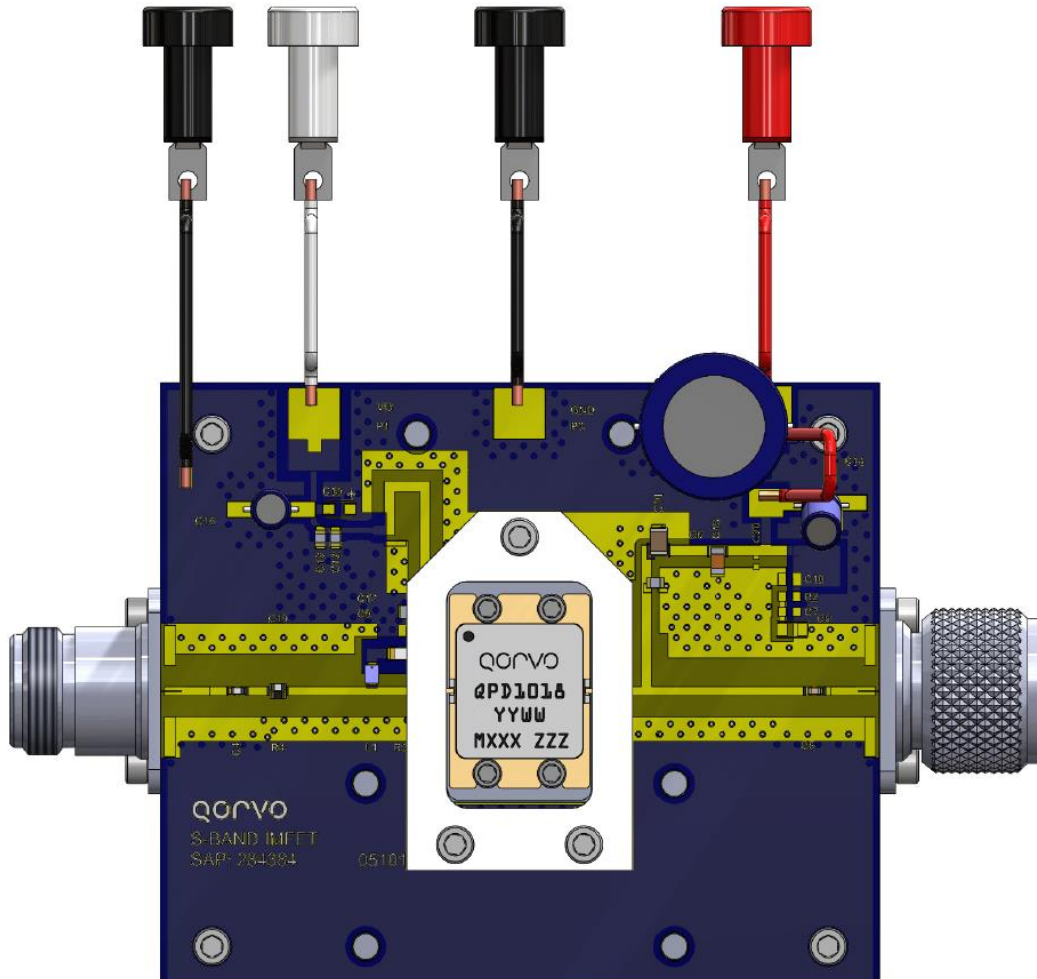

**Notes:**

1. PCB Material: RO4350B, 20 mil thickness, 1 oz copper cladding

## Bill of Material – 1.2 – 1.4 GHz EVB

Ref Des	Value	Qty	Manufacturer	Part Number
C1	680 uF	1	Panasonic	EEU-FC2A681
C4, C19	10 pF	2	ATC	ATC600S100JW250XT
C5	15 pF	1	ATC	ATC600S150FT250XT
C6, C9	10 pF	2	ATC	ATC600F100BT250XT
C12	10000 pF	1	AVX/Kyocera	08051C103KAZ2A
C11	0.1 uF	1	Murata	GRM32NR72A104KA01 L
C13	0.1 uF	1	Kemet	C0805C104K5RACTU
C14, C16	10 uF	2	Panasonic	ECA-2AM100
C17, C18	10000 pF	2	Samsung	CL31B103KGFNNE
R3	10 Ohm	1	Panasonic	ERJ-8GEYJ100V
R4	1 kOhm	1	Vishay	CRCW06031K00FKTA
L1	22 nH	1	Coilcraft	0805HT-22NTJLB

## Handling Precautions

Parameter	Rating	Standard
ESD – Human Body Model (HBM)	Class 2	ESDA / JEDEC JS-001-2012
ESD – Charged Device Model (CDM)	Class C3	JEDEC JESD22-C101F
MSL – Moisture Sensitivity Level	MLS3	IPC/JEDEC J-STD-020



Caution!  
ESD-Sensitive Device

## Solderability

The component leads should be manually soldered, and the package cannot be subjected to conventional reflow processes. Soldering of the component leads is compatible with the latest version of J-STD-020, lead-free solder, 260 °C. The use of no-clean solder to avoid washing after soldering is recommended.

## RoHS Compliance

This part is compliant with 2011/65/EU RoHS directive (Restrictions on the Use of Certain Hazardous Substances in Electrical and Electronic Equipment) as amended by Directive 2015/863/EU.

This product also has the following attributes:

- Antimony Free
- TBBP-A (C<sub>15</sub>H<sub>12</sub>Br<sub>4</sub>O<sub>2</sub>) Free
- PFOS Free
- SVHC Free

## Contact Information

For the latest specifications, additional product information, worldwide sales and distribution locations:

**Web:** [www.qorvo.com](http://www.qorvo.com)

**Tel:** 1-844-890-8163

**Email:** [customer.support@qorvo.com](mailto:customer.support@qorvo.com)

## Important Notice

The information contained in this Data Sheet and any associated documents (“Data Sheet Information”) is believed to be reliable; however, Qorvo makes no warranties regarding the Data Sheet Information and assumes no responsibility or liability whatsoever for the use of said information. All Data Sheet Information is subject to change without notice. Customers should obtain and verify the latest relevant Data Sheet Information before placing orders for Qorvo® products. Data Sheet Information or the use thereof does not grant, explicitly, implicitly or otherwise any rights or licenses to any third party with respect to patents or any other intellectual property whether with regard to such Data Sheet Information itself or anything described by such information.

DATA SHEET INFORMATION DOES NOT CONSTITUTE A WARRANTY WITH RESPECT TO THE PRODUCTS DESCRIBED HEREIN, AND QORVO HEREBY DISCLAIMS ANY AND ALL WARRANTIES WITH RESPECT TO SUCH PRODUCTS WHETHER EXPRESS OR IMPLIED BY LAW, COURSE OF DEALING, COURSE OF PERFORMANCE, USAGE OF TRADE OR OTHERWISE, INCLUDING THE IMPLIED WARRANTIES OF MERCHANTABILITY AND FITNESS FOR A PARTICULAR PURPOSE. Without limiting the generality of the foregoing, Qorvo® products are not warranted or authorized for use as critical components in medical, life-saving, or life-sustaining applications, or other applications where a failure would reasonably be expected to cause severe personal injury or death. Applications described in the Data Sheet Information are for illustrative purposes only. Customers are responsible for validating that a particular product described in the Data Sheet Information is suitable for use in a particular application.

© 2022 Qorvo US, Inc. All rights reserved. This document is subject to copyright laws in various jurisdictions worldwide and may not be reproduced or distributed, in whole or in part, without the express written consent of Qorvo US, Inc. | QORVO® is a registered trademark of Qorvo US, Inc.