

Product Overview

The QPD9300 is a 30 W (P_{3dB}) internally matched discrete GaN on SiC HEMT which operates from 9.2 to 9.7 GHz and a 28 V supply rail. The device is fully matched to 50 Ω in an industry standard air cavity package and is ideally suited for military and civilian radar. The device can support pulsed and linear operations.

ROHS compliant.

Evaluation boards are available upon request.

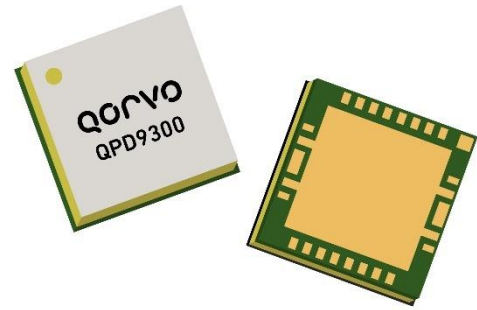

Functional Block Diagram

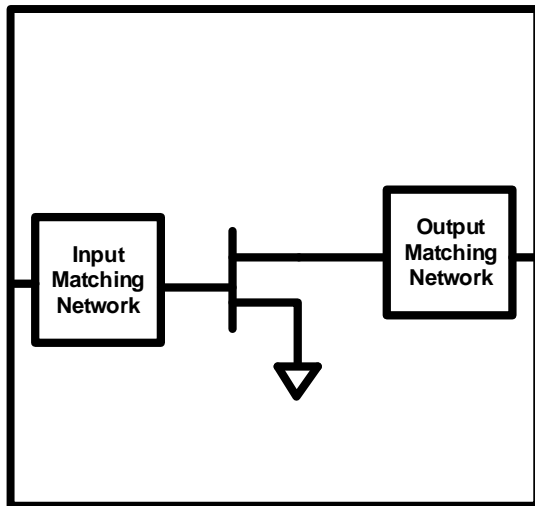

Key Features

- Frequency: 9.2 to 9.7 GHz
 - Output Power (P_{OUT})¹: 34.3 W
 - Gain¹: 9.1 dB
 - Typical DEFF¹: 48.6 %
 - Operating Voltage: 28 V
 - Low thermal resistance package
 - Pulse capable
- Note 1: @ 9.4 GHz and 37 dBm EVB input power

Applications

- Marine radar
- Civilian radar

Part No.	Description
QPD9300EVB3	9 – 10 GHz EVB
QPD9300SR	QPD9300 short reel of 100 parts.
QPD9300TR7	QPD9300 7" reel of 500 parts.



QPD9300

30 W, 28 V, 9.2 – 9.7 GHz, GaN RF IMFET

Absolute Maximum Ratings¹

Parameter	Rating	Units
Breakdown Voltage, BV_{DG}	+145	V
Gate Voltage Range, V_G	-7 to +2	V
Drain Current	11	A
Gate Current Range, I_G	See page 4.	mA
Power Dissipation, 10% DC 1 mS PW, P_{DISS}	78	W
RF Input Power, 10% DC 1 mS PW, 9.4 GHz, $T = 25^\circ\text{C}$	+43	dBm
Mounting Temperature (30 Seconds)	320	$^\circ\text{C}$
Storage Temperature	-65 to +150	$^\circ\text{C}$

Notes:

1. Operation of this device outside the parameter ranges given above may cause permanent damage.

Recommended Operating Conditions¹

Parameter	Min	Typ	Max	Units
Operating Temp. Range	-40	+25	+85	$^\circ\text{C}$
Drain Voltage Range, V_D	+24	+28	+32	V
Drain Bias Current, I_{DQ}	-	240	-	mA
Drain Current, I_D	-	0.5	-	A
Gate Voltage, V_G^4	-	-2.8	-	V
Power Dissipation, Pulsed (P_D) ^{2, 3}	-	-	62	W
Power Dissipation, CW (P_D) ²	-	-	37	W

Notes:

1. Electrical performance is measured under conditions noted in the electrical specifications table. Specifications are not guaranteed over all recommended operating conditions.
2. Package base at 85°C
3. Pulse Width = 100 μS , Duty Cycle = 10%
4. To be adjusted to desired I_{DQ}

**RF Characterization – 9 – 10 GHz EVB Performance At 9.4 GHz¹**

Parameter	Min	Typ	Max	Units
Gain, G	–	7.8	–	dB
Output Power, P _{OUT}	–	30.4	–	W
Drain Efficiency, DEFF	–	43.1	–	%

Notes:

1. EVB Input Power = 37 dBm, V_D = +28 V, I_{DQ} = 240 mA, Temp = +25 °C, Pulse Width = 100 μS, Duty Cycle = 10%.

RF Characterization – 9 – 10 GHz EVB Performance At 9.5 GHz¹

Parameter	Min	Typ	Max	Units
Gain, G	–	7.6	–	dB
Output Power, P _{OUT}	–	29.2	–	W
Drain Efficiency, DEFF	–	41.8	–	%

Notes:

1. EVB Input Power = 37 dBm, V_D = +28 V, I_{DQ} = 240 mA, Temp = +25 °C, Pulse Width = 100 μS, Duty Cycle = 10%.

RF Characterization – 9 – 10 GHz EVB Performance At 9.6 GHz¹

Parameter	Min	Typ	Max	Units
Gain, G	–	7.5	–	dB
Output Power, P _{OUT}	–	28.2	–	W
Drain Efficiency, DEFF	–	39.7	–	%

Notes:

1. EVB Input Power = 37 dBm, V_D = +28 V, I_{DQ} = 240 mA, Temp = +25 °C, Pulse Width = 100 μS, Duty Cycle = 10%.

RF Characterization – Mismatch Ruggedness at 9.3 - 9.6 GHz^{1, 2}

Symbol	Parameter	Typical
VSWR	Impedance Mismatch Ruggedness	3:1

Notes:

1. Test conditions unless otherwise noted: T_A = +25 °C, V_D = 28 V, I_{DQ} = 240 mA, 1 mS PW, 10% DC
2. Driving input power is 43 dBm under matched condition at EVB input connector.

Maximum Gate Current

Maximum Gate Current vs. IR Surface Temperature

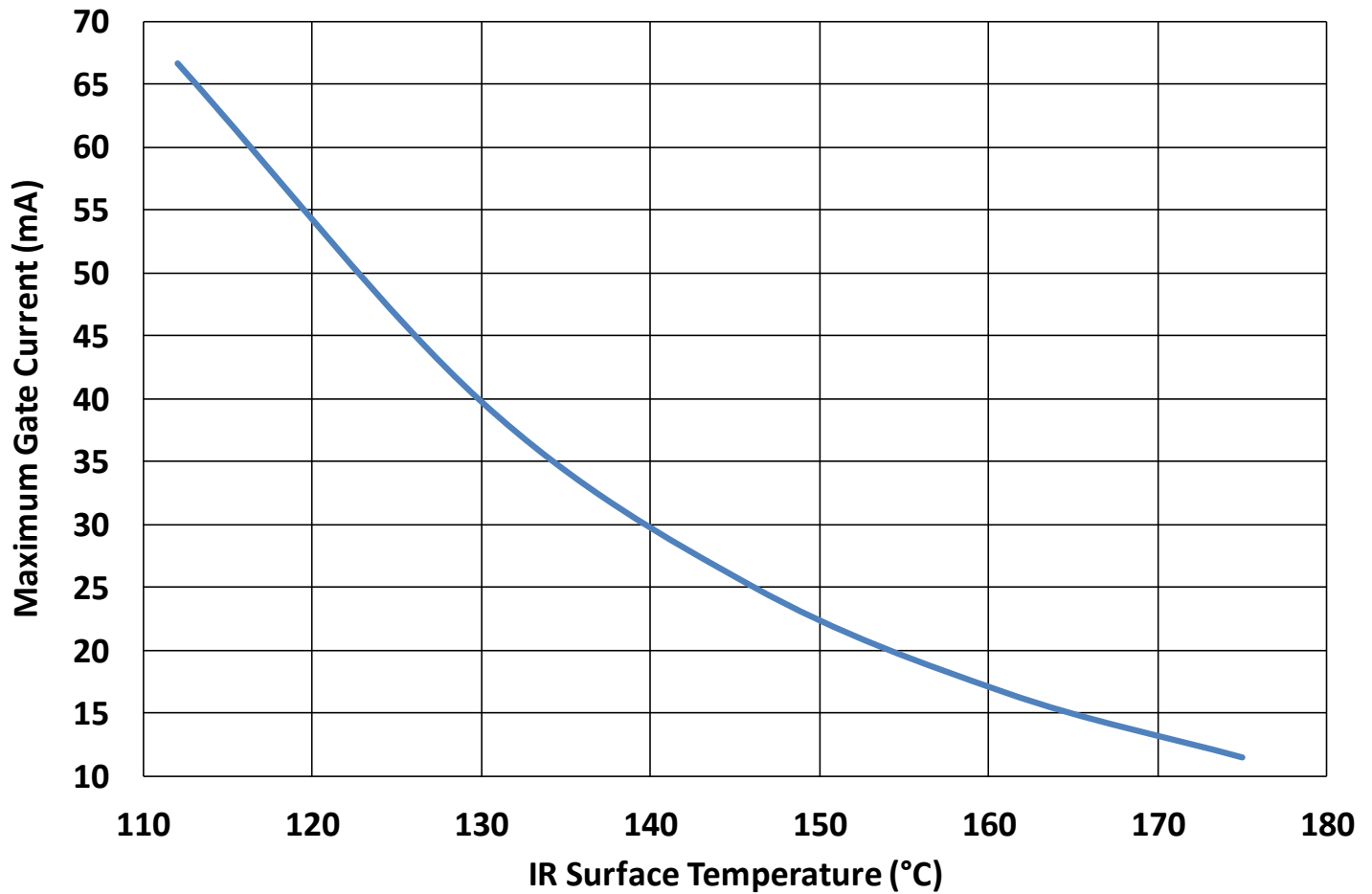

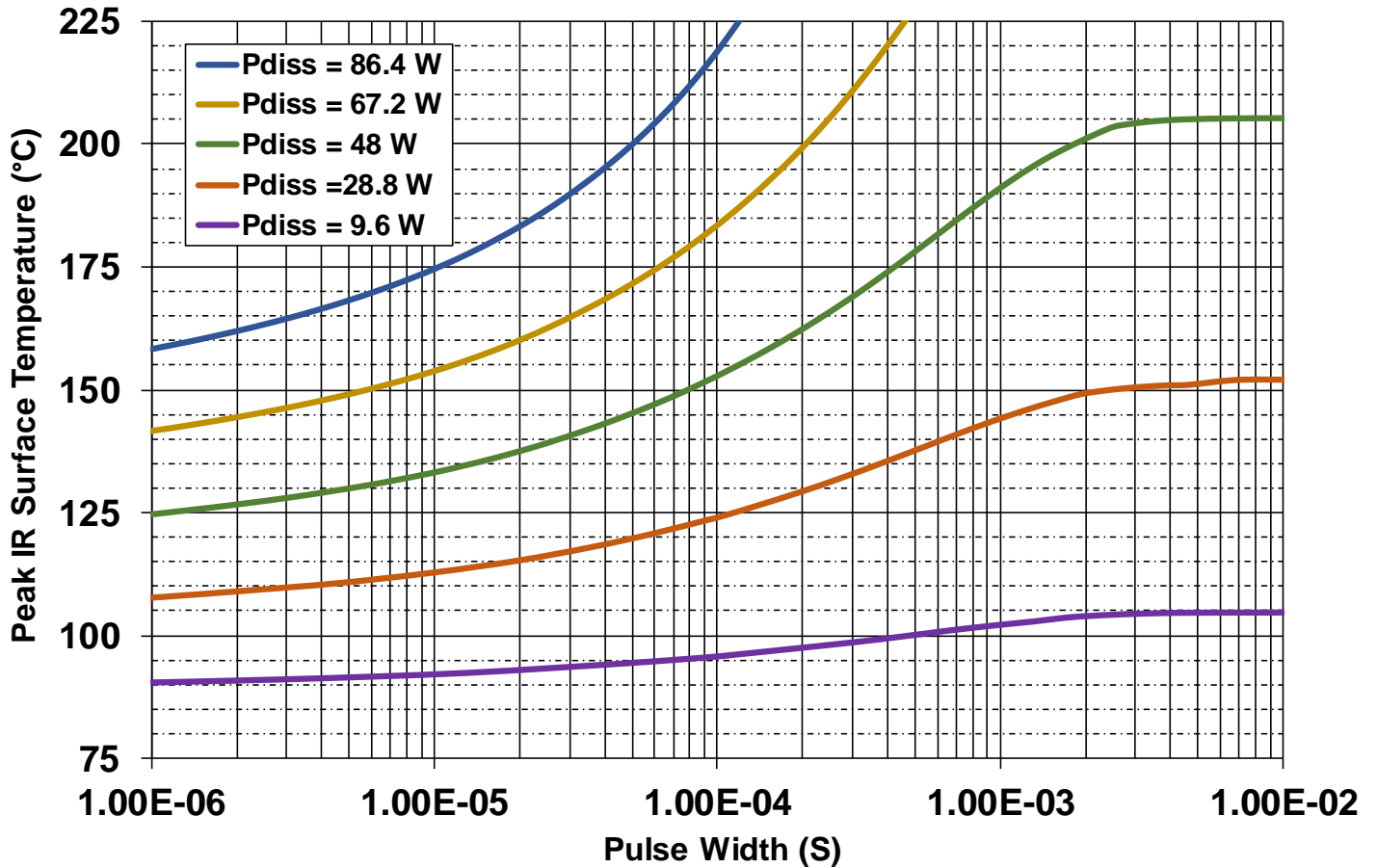
Thermal and Reliability Information – Pulsed¹
**Peak IR Surface Temperature vs. Pulse Width vs. Dissipation Power
10% Duty Cycle, Backside of Package At 85°C**

Parameter	Conditions	Values	Units
Thermal Resistance, IR (θ_{JC})	85 °C Case	1.15	°C/W
Peak IR Surface Temperature (T_{CH})	9.6 W Pdiss, 100 uS PW, 10% DC	96	°C
Thermal Resistance, IR (θ_{JC})	85 °C Case	1.35	°C/W
Peak IR Surface Temperature (T_{CH})	28.8 W Pdiss, 100 uS PW, 10% DC	124	°C
Thermal Resistance, IR (θ_{JC})	85 °C Case	1.42	°C/W
Peak IR Surface Temperature (T_{CH})	48 W Pdiss, 100 uS PW, 10% DC	153	°C
Thermal Resistance, IR (θ_{JC})	85 °C Case	1.46	°C/W
Peak IR Surface Temperature (T_{CH})	67.2 W Pdiss, 100 uS PW, 10% DC	183	°C
Thermal Resistance, IR (θ_{JC})	85 °C Case	1.54	°C/W
Peak IR Surface Temperature (T_{CH})	86.4 W Pdiss, 100 uS PW, 10% DC	218	°C

¹Refer to the following document [GaN Device Channel Temperature, Thermal Resistance, and Reliability Estimates](#)

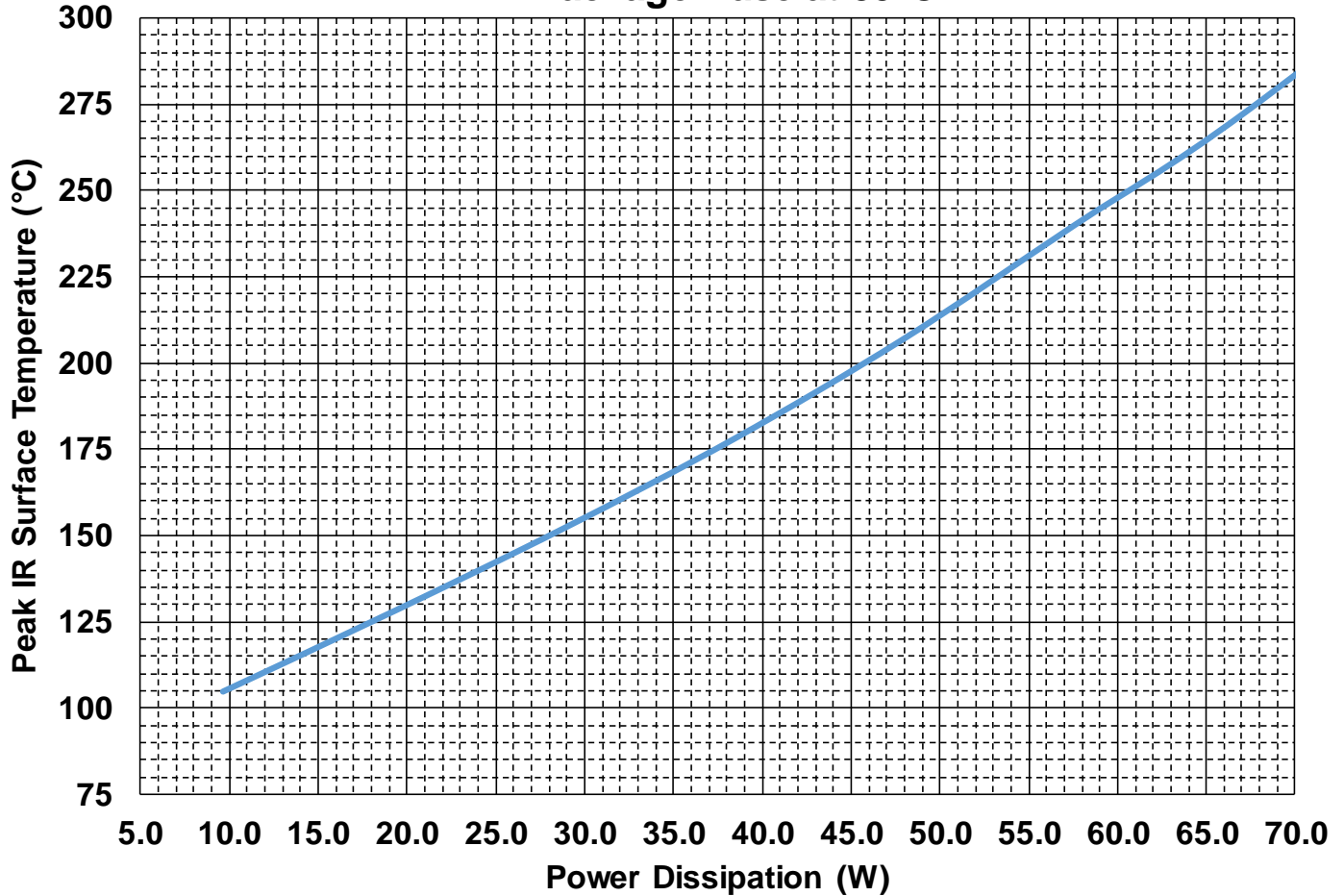
Thermal and Reliability Information – CW¹
**Peak IR Surface Temperature vs. Power
Package Base at 85°C**

Parameter	Conditions	Values	Units
Thermal Resistance, IR (θ_{JC})	85 °C Case	2.24	°C/W
Peak IR Surface Temperature (T_{CH})	19.2 W Pdiss, CW	128	°C
Thermal Resistance, IR (θ_{JC})	85 °C Case	2.33	°C/W
Peak IR Surface Temperature (T_{CH})	28.8 W Pdiss, CW	152	°C
Thermal Resistance, IR (θ_{JC})	85 °C Case	2.42	°C/W
Peak IR Surface Temperature (T_{CH})	38.4 W Pdiss, CW	178	°C
Thermal Resistance, IR (θ_{JC})	85 °C Case	2.54	°C/W
Peak IR Surface Temperature (T_{CH})	48 W Pdiss, CW	207	°C
Thermal Resistance, IR (θ_{JC})	85 °C Case	2.69	°C/W
Peak IR Surface Temperature (T_{CH})	57.6 W Pdiss, CW	240	°C

¹Refer to the following document [GaN Device Channel Temperature, Thermal Resistance, and Reliability Estimates](#)

S-Parameters Over Temperatures Of 9 – 10 GHz EVB¹

Notes:

1. $V_D = 28\text{ V}$, $I_{DQ} = 240\text{ mA}$.

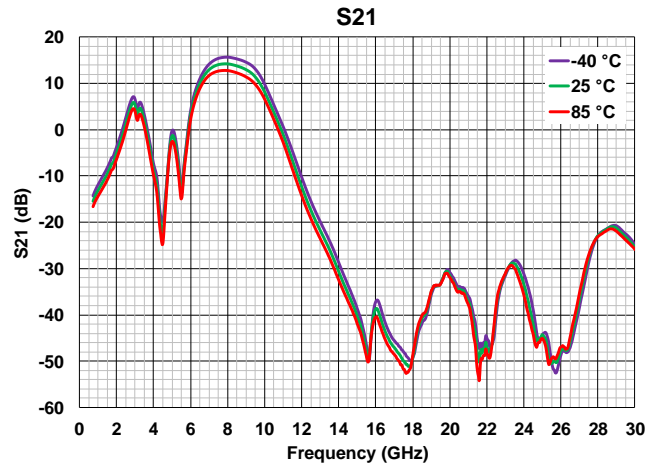
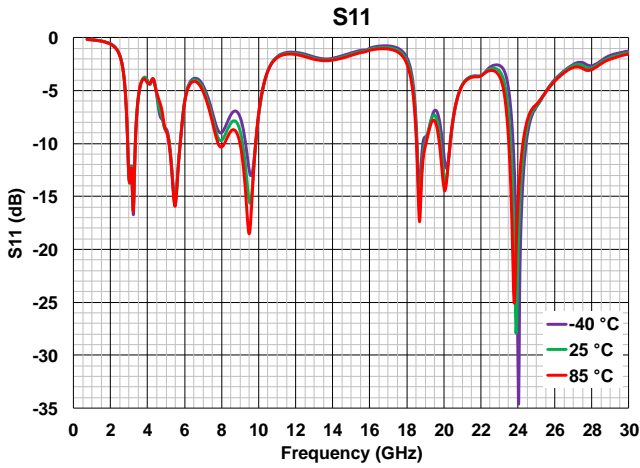

2.

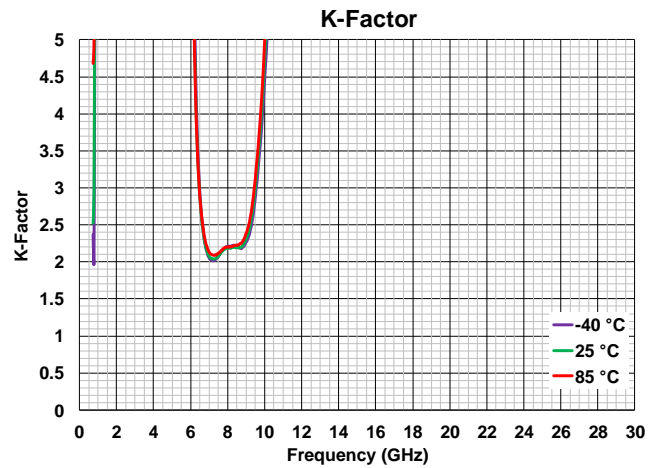
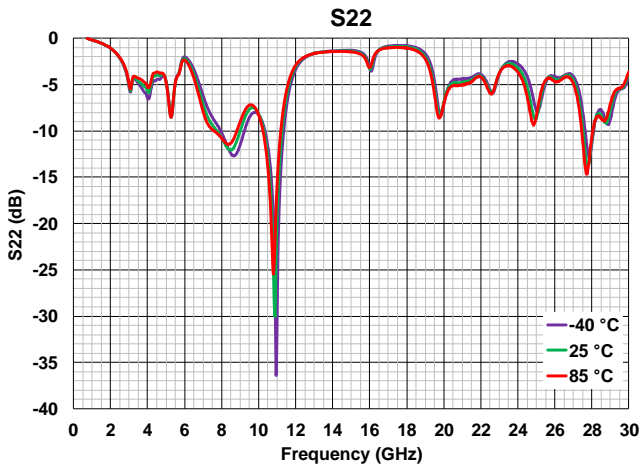

Power Performance Over Temperatures Of 9 – 10 GHz EVB^{1,2}

Notes:

1. At QPD9300 Package.
2. EVB Input Power = 37 dBm, $V_D = 28\text{ V}$, $I_{DQ} = 240\text{ mA}$, $100\ \mu\text{S PW}$, 10% DC.

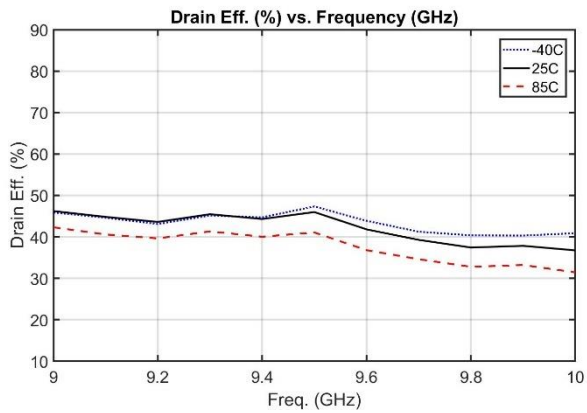
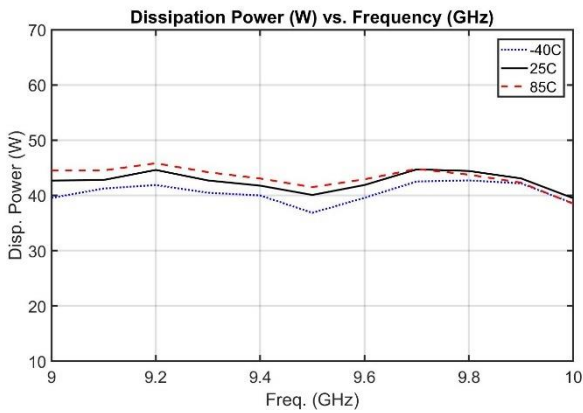
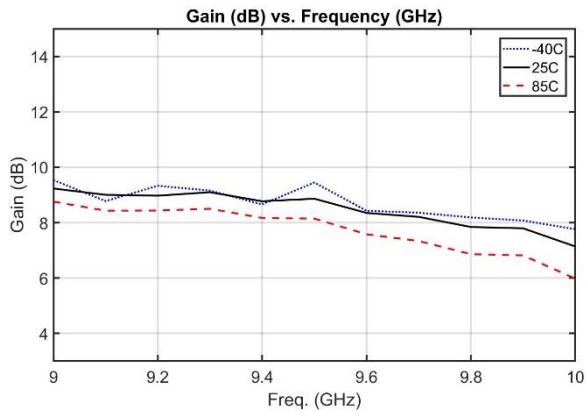
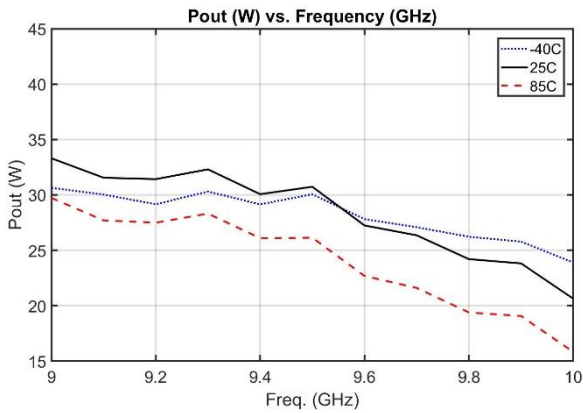

Power Performance Over Temperatures and V_D Of 9 – 10 GHz EVB^{1,2}

Notes:

1. At QPD9300 Package.
2. EVB Input Power = 37 dBm, I_{DQ} = 240 mA, 100 μ S PW, 10% DC

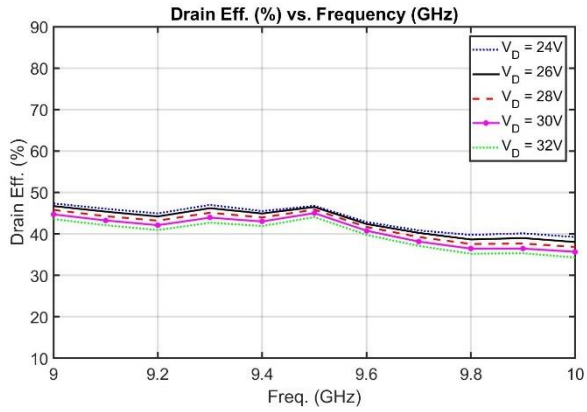
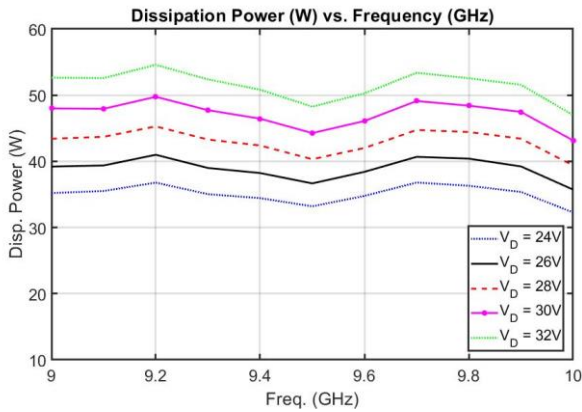
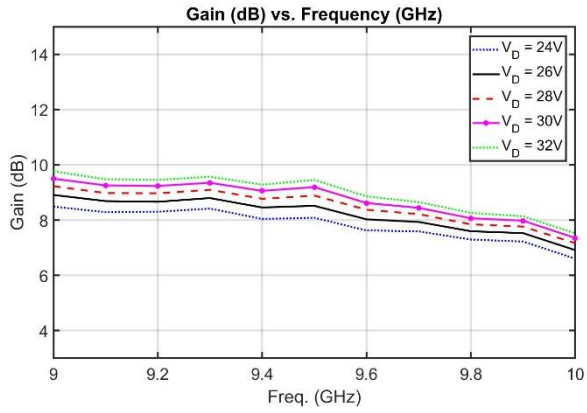
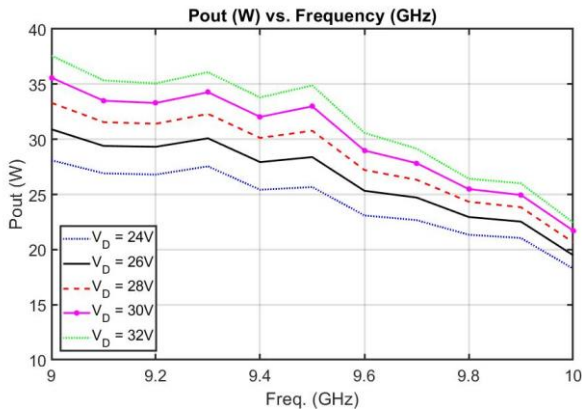

Pin Configuration and Description, and Package Marking¹

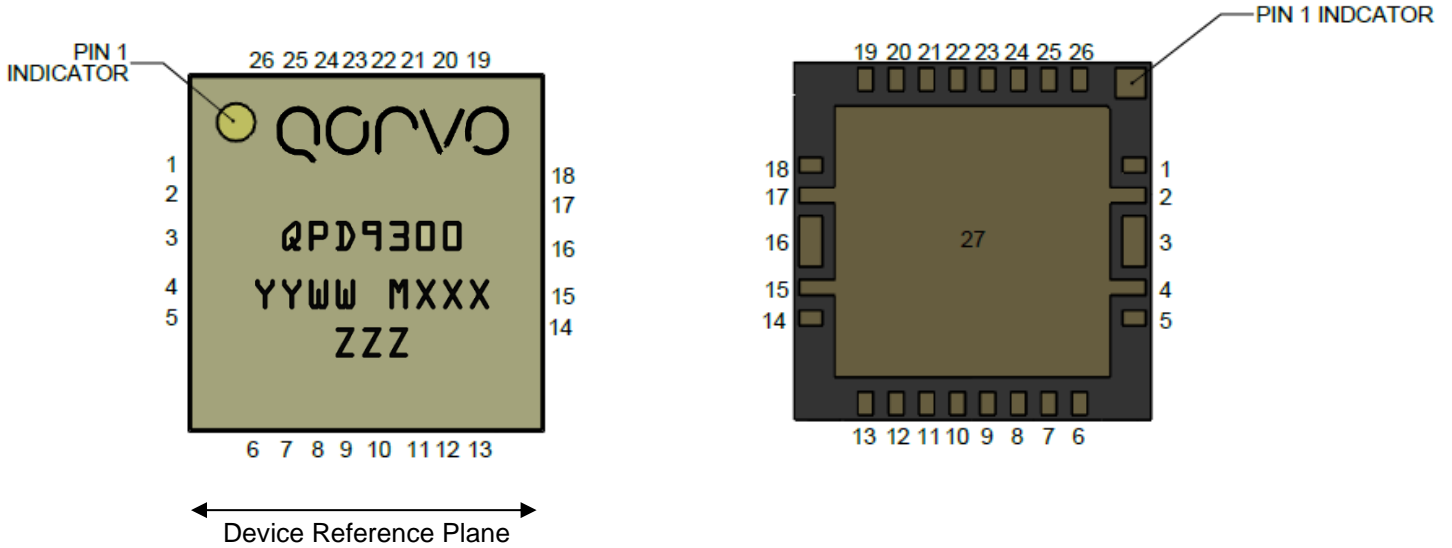

Notes:

- The QPD9300 will be marked with the “QPD9300” designator and a lot code marked below the part designator. The “YY” represents the last two digits of the calendar year the part was manufactured, the “WW” is the work week of the assembly lot

Pin Description

Pin	Symbol	Description
3	V_G / RF IN	Gate voltage / RF Input
16	V_D / RF OUT	Drain voltage / RF Output
1, 5, 6, 7, 8, 9, 10, 11, 12, 13, 14, 18, 19, 20, 21, 22, 23, 24, 25, 26	N/C	No Connection ¹
2, 4, 15, 17, 27	GND	Package Base

¹ To be grounded in board layout.

start, the “MXXX” is the batch ID, ZZZ is unique for all parts within one assembly lot.

Package Dimensions^{1, 2, 3, 4, 5}

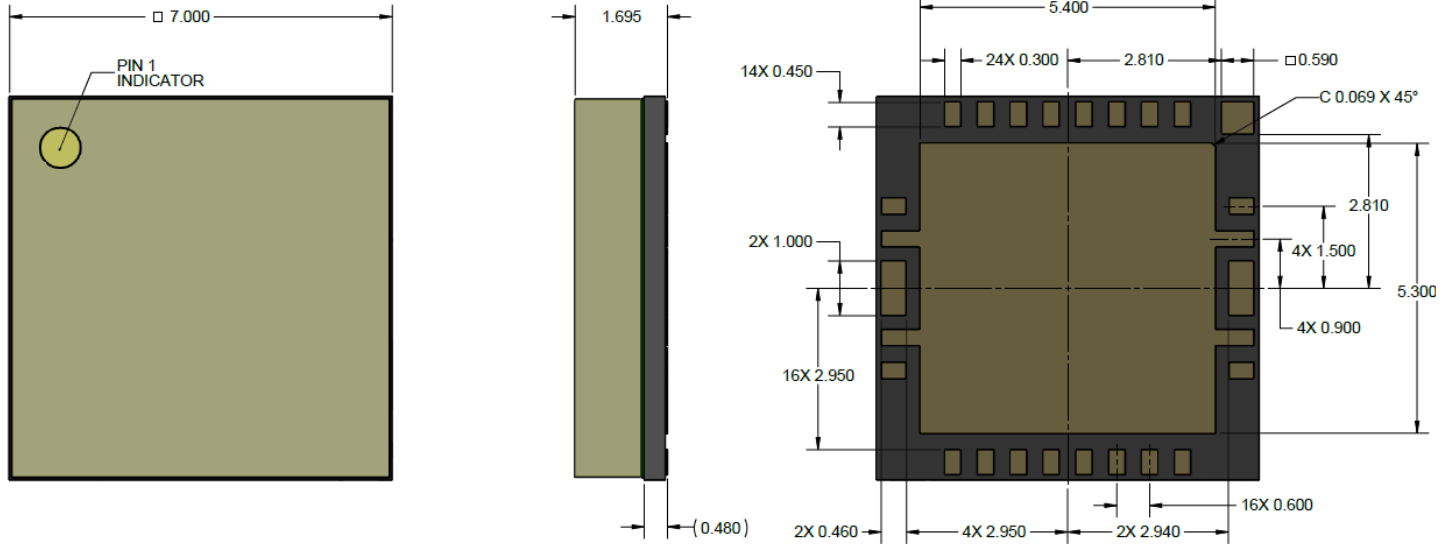

Notes:

1. Dimension unit is mm.
2. Unless otherwise noted, dimension tolerance is ± 0.127 mm.
3. Material:
 Package Base: Laminate
 Package Lid: Laminate
4. Package exposed metallization is gold plated.
5. Part is epoxy sealed.

Schematic – 9 – 10 GHz EVB

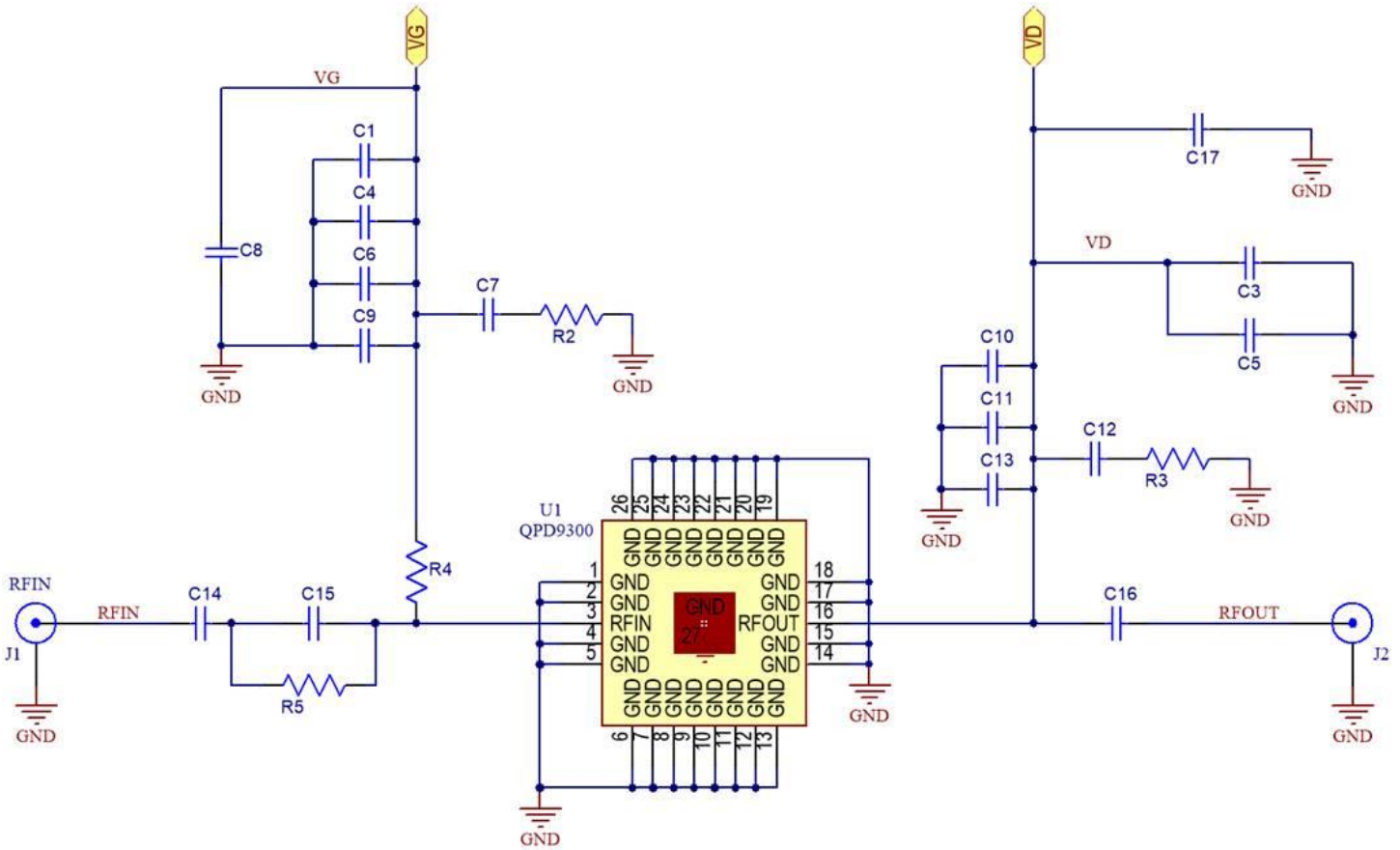

Bias-up Procedure	Bias-down Procedure
1. Set V_G to -4 V	1. Turn off RF signal
2. Set I_D current limit to 250 mA	2. Turn off V_D
3. Apply 28 V V_D	3. Wait 2 seconds to allow drain capacitor to discharge
4. Slowly adjust V_G until I_D is set to 240 mA	4. Turn off V_G
5. Set I_D current limit to 0.6 A	
6. Apply RF	

Layout - 9 – 10 GHz EVB¹

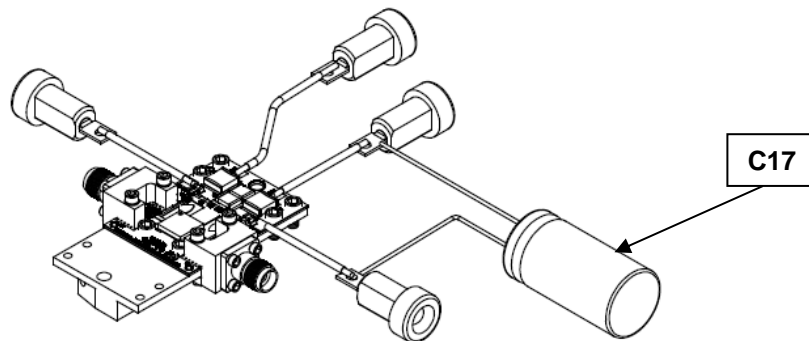
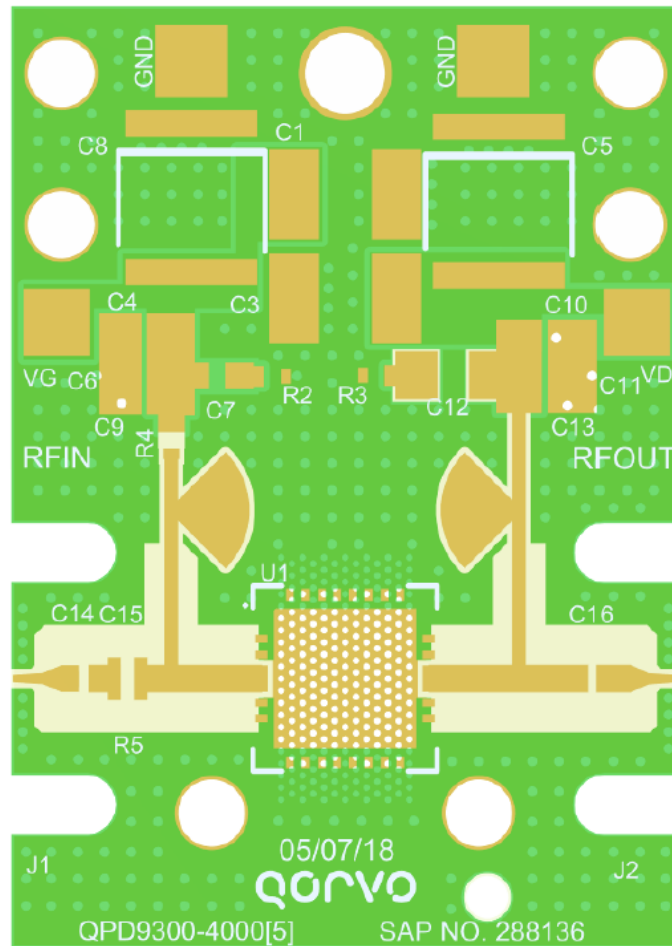

Notes:

1. PCB Material: RO4350B, 20 mil thickness, 1 oz copper cladding



QPD9300

30 W, 28 V, 9.2 – 9.7 GHz, GaN RF IMFET

Bill Of material – 9 – 10 GHz EVB

Ref Des	Value	Qty	Manufacturer	Part Number
C4, C10	10000 pF, 100 V	2	AVX	08051C103KAZ2A
C1, C3	1 uF, 100 V	2	AVX	18121C105KAT2A
C6, C11	100 pF, 250 V	2	AVX	UQCSVA101JAT2A\500
C9, C13	1.8 pF, 200 V	2	AVX	UQCL2A1R8BAT2A\500
C14, C15, C16	1.0 pF, 200 V	3	AVX	UQCL2A1R0BAT2A\500
C5, C8	10 uF, 100 V	2	Murata	22201C106MAT2A
C17	220 uF, 100 V	1	Nichicon	UVY2A221MHD1TO
R4	10 Ω	1	Panasonic	ERJ-2GEJ100X
R5	1 k Ω	1	Panasonic	ERJ-PA2J102X
J1, J2	Connector	2	Southwest Microwave	1092-01A-5
C7, C12, R2, R3	Do Not Place			

Recommended Solder Temperature Profile

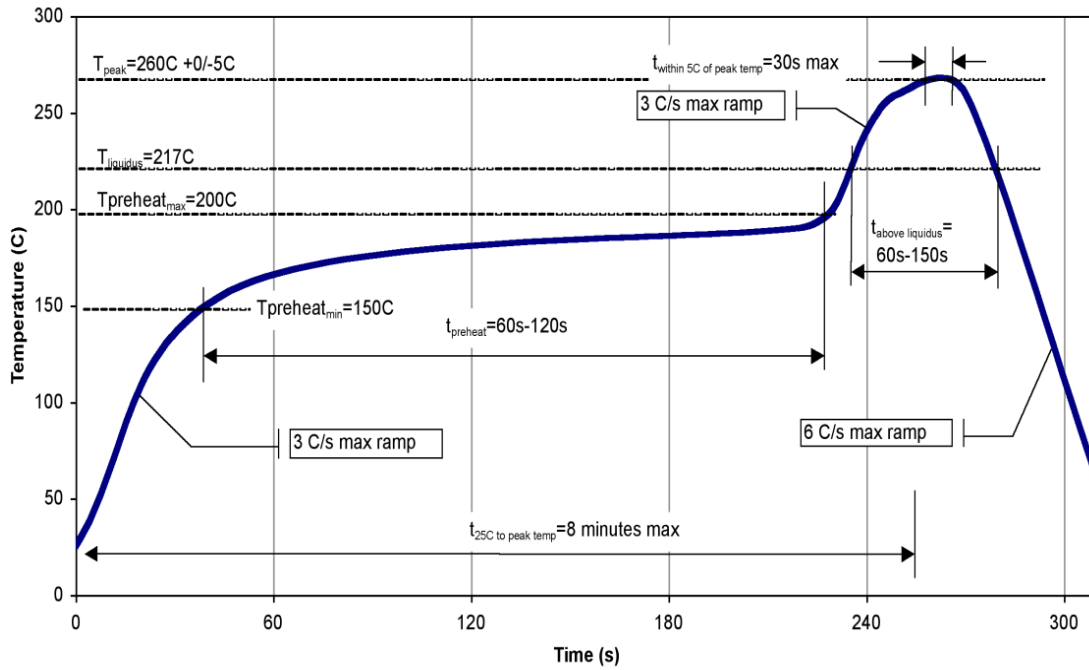

Handling Precautions

Parameter	Rating	Standard
ESD – Human Body Model (HBM)	1B (500V)	ANSI/ESD/JEDEC JS-001
ESD – Charged Device Model (CDM)	C3 (1000V)	ANSI/ESD/JEDEC JS-002
MSL – Moisture Sensitivity Level	MSL3	IPC/JEDEC J-STD-020



Caution!
ESD-Sensitive Device

Solderability

Compatible with both lead-free (260°C max. reflow temp.) and tin/lead (245°C max. reflow temp.) soldering processes. Solder profiles available upon request.

Package lead plating is NiAu. Au thickness is 0.095 µm.

RoHS Compliance

This part is compliant with 2011/65/EU RoHS directive (Restrictions on the Use of Certain Hazardous Substances in Electrical and Electronic Equipment) as amended by Directive 2015/863/EU.

This product also has the following attributes:

- Antimony Free
- Lead Free
- TBBP-A (C₁₅H₁₂Br₄O₂) Free
- PFOS Free

Contact Information

For the latest specifications, additional product information, worldwide sales and distribution locations:

Web: www.qorvo.com

Tel: 1-844-890-8163

Email: customer.support@qorvo.com

Important Notice

The information contained in this Data Sheet and any associated documents (“Data Sheet Information”) is believed to be reliable; however, Qorvo makes no warranties regarding the Data Sheet Information and assumes no responsibility or liability whatsoever for the use of said information. All Data Sheet Information is subject to change without notice. Customers should obtain and verify the latest relevant Data Sheet Information before placing orders for Qorvo® products. Data Sheet Information or the use thereof does not grant, explicitly, implicitly or otherwise any rights or licenses to any third party with respect to patents or any other intellectual property whether with regard to such Data Sheet Information itself or anything described by such information.

DATA SHEET INFORMATION DOES NOT CONSTITUTE A WARRANTY WITH RESPECT TO THE PRODUCTS DESCRIBED HEREIN, AND QORVO HEREBY DISCLAIMS ANY AND ALL WARRANTIES WITH RESPECT TO SUCH PRODUCTS WHETHER EXPRESS OR IMPLIED BY LAW, COURSE OF DEALING, COURSE OF PERFORMANCE, USAGE OF TRADE OR OTHERWISE, INCLUDING THE IMPLIED WARRANTIES OF MERCHANTABILITY AND FITNESS FOR A PARTICULAR PURPOSE. Without limiting the generality of the foregoing, Qorvo® products are not warranted or authorized for use as critical components in medical, life-saving, or life-sustaining applications, or other applications where a failure would reasonably be expected to cause severe personal injury or death. Applications described in the Data Sheet Information are for illustrative purposes only. Customers are responsible for validating that a particular product described in the Data Sheet Information is suitable for use in a particular application.

© 2020 Qorvo US, Inc. All rights reserved. This document is subject to copyright laws in various jurisdictions worldwide and may not be reproduced or distributed, in whole or in part, without the express written consent of Qorvo US, Inc. | QORVO® is a registered trademark of Qorvo US, Inc.