





Vincotech

<i>flowPIM 1</i>	600 V / 30 A				
<table border="1" style="width: 100%; border-collapse: collapse;"> <thead> <tr style="background-color: #ccc;"> <th style="text-align: center; padding: 2px;">Features</th> </tr> </thead> <tbody> <tr> <td style="padding: 2px;"> <ul style="list-style-type: none"> Trench Fieldstop Technology IGBT3 for low saturation loss Supports design with 90° mounting angle between heatsink and PCB Clip-in PCB mounting Clip or screw on heatsink mounting </td> </tr> </tbody> </table>	Features	<ul style="list-style-type: none"> Trench Fieldstop Technology IGBT3 for low saturation loss Supports design with 90° mounting angle between heatsink and PCB Clip-in PCB mounting Clip or screw on heatsink mounting 	<table border="1" style="width: 100%; border-collapse: collapse;"> <thead> <tr style="background-color: #ccc;"> <th style="text-align: center; padding: 2px;"><i>flow 90 1 housing</i></th> </tr> </thead> <tbody> <tr> <td style="text-align: center; padding: 10px;">  </td> </tr> </tbody> </table>	<i>flow 90 1 housing</i>	
Features					
<ul style="list-style-type: none"> Trench Fieldstop Technology IGBT3 for low saturation loss Supports design with 90° mounting angle between heatsink and PCB Clip-in PCB mounting Clip or screw on heatsink mounting 					
<i>flow 90 1 housing</i>					
					
<table border="1" style="width: 100%; border-collapse: collapse;"> <thead> <tr style="background-color: #ccc;"> <th style="text-align: center; padding: 2px;">Target applications</th> </tr> </thead> <tbody> <tr> <td style="padding: 2px;"> <ul style="list-style-type: none"> Industrial drives </td> </tr> </tbody> </table>	Target applications	<ul style="list-style-type: none"> Industrial drives 	<table border="1" style="width: 100%; border-collapse: collapse;"> <thead> <tr style="background-color: #ccc;"> <th style="text-align: center; padding: 2px;">Schematic</th> </tr> </thead> <tbody> <tr> <td style="text-align: center; padding: 10px;">  </td> </tr> </tbody> </table>	Schematic	
Target applications					
<ul style="list-style-type: none"> Industrial drives 					
Schematic					
					
<table border="1" style="width: 100%; border-collapse: collapse;"> <thead> <tr style="background-color: #ccc;"> <th style="text-align: center; padding: 2px;">Types</th> </tr> </thead> <tbody> <tr> <td style="padding: 2px;"> <ul style="list-style-type: none"> V23990-P635-A-PM </td> </tr> </tbody> </table>	Types	<ul style="list-style-type: none"> V23990-P635-A-PM 			
Types					
<ul style="list-style-type: none"> V23990-P635-A-PM 					

Maximum Ratings

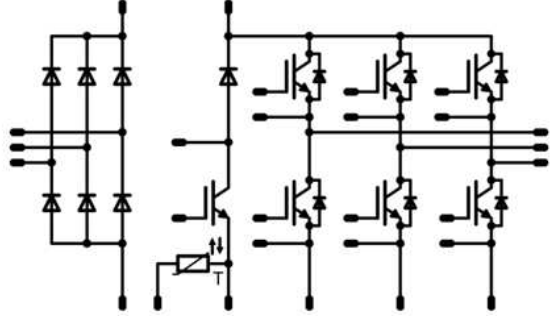
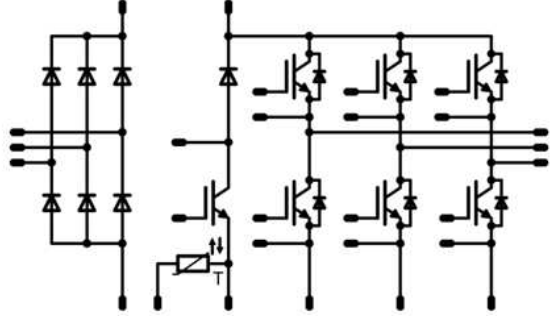
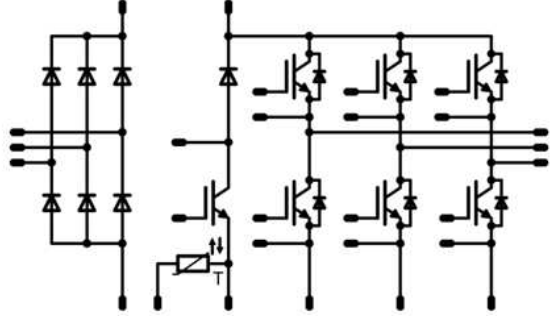
$T_j=25^{\circ}\text{C}$, unless otherwise specified

Parameter	Symbol	Condition	Value	Unit
Inverter Switch				
Collector-emitter voltage	V_{CES}		600	V
Collector current	I_C	$T_j=T_{jmax}$ $T_S=80^{\circ}\text{C}$	36	A
Repetitive peak collector current	I_{CRM}	t_p limited by T_{jmax}	90	A
Total power dissipation	P_{tot}	$T_j=T_{jmax}$ $T_S=80^{\circ}\text{C}$	73	W
Gate-emitter voltage	V_{GES}		±20	V
Maximum Junction Temperature	T_{jmax}		175	°C



Vincotech

Parameter	Symbol	Conditions	Value	Unit
Inverter Diode				
Peak Repetitive Reverse Voltage	V_{RRM}		600	V
Continuous (direct) forward current	I_F	$T_j=T_{jmax}$ $T_h=80^{\circ}C$	32	A
Repetitive peak forward current	I_{FRM}		90	A
Total power dissipation	P_{tot}	$T_j=T_{jmax}$ $T_h=80^{\circ}C$	52	W
Maximum Junction Temperature	T_{jmax}		175	$^{\circ}C$

Parameter	Symbol	Condition	Value	Unit
Brake Switch				
Collector-emitter voltage	V_{CES}		600	V
Collector current	I_C	$T_j=T_{jmax}$ $T_s=80^{\circ}C$	24	A
Repetitive peak collector current	I_{CRM}	t_p limited by T_{jmax}	60	A
Total power dissipation	P_{tot}	$T_j=T_{jmax}$ $T_s=80^{\circ}C$	53	W
Gate-emitter voltage	V_{GES}		± 20	V
Short circuit ratings	t_{SC}	$T_j \leq 150^{\circ}C$	6	μs
	V_{CC}	$V_{GE} = 15V$	360	V
Maximum Junction Temperature	T_{jmax}		175	$^{\circ}C$

Parameter	Symbol	Conditions	Value	Unit
Brake Diode				
Peak Repetitive Reverse Voltage	V_{RRM}		600	V
Continuous (direct) forward current	I_F	$T_j=T_{jmax}$ $T_h=80^{\circ}C$	24	A
Repetitive peak forward current	I_{FRM}		40	A
Total power dissipation	P_{tot}	$T_j=T_{jmax}$ $T_h=80^{\circ}C$	40	W
Maximum Junction Temperature	T_{jmax}		175	$^{\circ}C$



Parameter	Symbol	Conditions	Value	Unit
Rectifier Diode				
Repetitive peak reverse voltage	V_{RRM}		1600	V
Mean forward current	I_{FAV}	$T_j = T_{jmax}$ $T_s = 80\text{ °C}$	33	A
Surge (non-repetitive) forward current	I_{FSM}	50 Hz Single Half Sine Wave	200	A
Surge current capability	I^2t	$t_p = 10\text{ ms}$ 50 Hz sine $T_j = 150\text{ °C}$	200	A ² s
Total power dissipation	P_{tot}	$T_j = T_{jmax}$ $T_s = 80\text{ °C}$	43	W
Maximum Junction Temperature	T_{jmax}		150	°C

Parameter	Symbol	Conditions	Value	Unit
Module Properties				
Thermal Properties				
Storage temperature	T_{stg}		-40...+125	°C
Operation Junction Temperature	T_{jop}		-40...+($T_{jmax} - 25$)	°C

Isolation Properties					
Isolation voltage	V_{isol}	DC voltage	$t_p=2s$	4000	V
Creepage distance				min 12,7	mm
Clearance				min 11,84	mm
Comparative Tracking Index	CTI			>200	



Characteristic Values

Inverter Switch

Parameter	Symbol	Conditions					Value			Unit
		V_{GE} [V]	V_{CE} [V]	I_C [A]	T_j [°C]	Min	Typ	Max		
Static										
Gate-emitter threshold voltage	$V_{GE(th)}$	$V_{CE}=V_{CE}$			0,00015	25 125	5	5,8	6,5	V
Collector-emitter saturation voltage	V_{CEsat}		15		30	25 125	1,1	1,51 1,71	1,9	V
Collector-emitter cut-off current	I_{CES}		0	600		25 125			1,6	µA
Gate-emitter leakage current	I_{GES}		20	0		25 125			300	nA
Internal gate resistance	r_g							none		Ω
Input capacitance	C_{ies}							1630		pF
Output capacitance	C_{oes}	f=1 MHz	0	25		25		108		
Reverse transfer capacitance	C_{res}							50		
Gate charge	Q_g		15	400	30	25		167		nC

Thermal

Thermal resistance junction to sink	$R_{th(j-s)}$	Phase-Change Material $\lambda=3,4W/mK$						1,29		K/W
-------------------------------------	---------------	--	--	--	--	--	--	------	--	-----

IGBT Switching

Turn-on delay time	$t_{d(on)}$	$R_{goff} = 4 \Omega$ $R_{gon} = 8 \Omega$	15/0	300	30	25 125		20 19		ns
Rise time	t_r					25 125		17 19		
Turn-off delay time	$t_{d(off)}$					25 125		165 181		
Fall time	t_f					25 125		78 85		
Turn-on energy (per pulse)	E_{on}	$Q_{rFWD} = 1,4 \mu C$ $Q_{fFWD} = 2,4 \mu C$				25 125		0,673 0,877		mWs
Turn-off energy (per pulse)	E_{off}					25 125		0,676 0,852		



Vincotech

Inverter Diode

Parameter	Symbol	Conditions					Value			Unit
				V_r [V]	I_F [A]	T_j [°C]	Min	Typ	Max	

Static

Forward voltage	V_F				30	25 125 150		1,65 1,62 -	1,95	V
Reverse leakage current	I_r			600		25 150			200 -	μ A

Thermal

Thermal resistance junction to sink	$R_{th(j-s)}$	Phase-Change Material $\lambda=3,4W/mK$						1,84		K/W
-------------------------------------	---------------	---	--	--	--	--	--	------	--	-----

FWD Switching

Peak recovery current	I_{RRM}	$di/dt = 1640 A/\mu s$ $di/dt = 1459 A/\mu s$	15/0	300	30	25		20		A
Reverse recovery time	t_{rr}					125		22		ns
						25		210		
Recovered charge	Q_r					125		291		μ C
						25		1,390		
Reverse recovered energy	E_{rec}	125		2,445		mWs				
		25		0,263						
Peak rate of fall of recovery current	$(di_{rr}/dt)_{max}$	125		0,491		A/ μ s				
		25		1153						
						648				



Vincotech

Brake Switch

Parameter	Symbol	Conditions					Value			Unit
		V_{GE} [V]	V_{CE} [V]	I_C [A]	T_j [°C]	Min	Typ	Max		
Static										
Gate-emitter threshold voltage	$V_{GE(th)}$	$V_{GE}=V_{CE}$			0,00029	25 125	5	5,8	6,5	V
Collector-emitter saturation voltage	V_{CEsat}		15		20	25 125 150	1,1	1,52 -	1,9	V
Collector-emitter cut-off current	I_{CES}		0	600		25 125			1,1	μA
Gate-emitter leakage current	I_{GES}		20	0		25 125			300	nA
Internal gate resistance	r_g							none		Ω
Input capacitance	C_{ies}							1100		pF
Output capacitance	C_{oes}	f=1 MHz	0	25		25		71		
Reverse transfer capacitance	C_{res}							32		
Gate charge	Q_g		15	480	20	25		120		nC

Thermal

Thermal resistance junction to sink	$R_{th(j-s)}$	Phase-Change Material $\lambda=3,4W/mK$						1,81		K/W
-------------------------------------	---------------	--	--	--	--	--	--	------	--	-----

IGBT Switching

Turn-on delay time	$t_{d(on)}$	$R_{goff} = 16 \Omega$ $R_{gon} = 16 \Omega$	±15	300	20	25		71		ns
Rise time	t_r					150		70		
Turn-off delay time	$t_{d(off)}$					25		122		
Fall time	t_f					150		143		
Turn-on energy (per pulse)	E_{on}	$Q_{rFWD} = 0,8 \mu C$ $Q_{rFWD} = 1,7 \mu C$				25		0,259		mWs
Turn-off energy (per pulse)	E_{off}					150		0,380		
						25		0,448		
						150		0,613		



Vincotech

Brake Diode

Parameter	Symbol	Conditions					Value			Unit
		V_r [V]	I_F [A]	T_j [°C]	Min	Typ	Max			

Static

Forward voltage	V_F				20	25 125 150		1,70 1,58 -	1,95	V
Reverse leakage current	I_r			600		25 150			27 -	μ A

Thermal

Thermal resistance junction to sink	$R_{th(j-s)}$	Phase-Change Material $\lambda=3,4$ W/mK						2,37		K/W
-------------------------------------	---------------	---	--	--	--	--	--	------	--	-----

FWD Switching

Peak recovery current	I_{RRM}	$di/dt = 2072$ A/ μ s $di/dt = 1922$ A/ μ s	± 15	300	20	25 150		22 26		A
Reverse recovery time	t_{rr}					25 150		125 204		ns
Recovered charge	Q_r					25 150		0,809 1,713		μ C
Reverse recovered energy	E_{rec}					25 150		0,171 0,373		mWs
Peak rate of fall of recovery current	$(di_{rr}/dt)_{max}$					25 150		2050 741		A/ μ s

Rectifier Diode

Parameter	Symbol	Conditions					Value			Unit
		V_r [V]	I_F [A]	T_j	Min	Typ	Max			

Static

Forward voltage	V_F				25	25°C 125°C 150°C		1,22 1,21 -	1,9	V
Reverse leakage current	I_R			1600		25°C 150°C			50 1100	μ A

Thermal

Thermal resistance junction to case	$R_{th(j-c)}$	Phase-Change Material $\lambda=3,4$ W/mK						1,61		K/W
-------------------------------------	---------------	---	--	--	--	--	--	------	--	-----



Vincotech

Thermistor

Parameter	Symbol		Conditions				Value			Unit
			V_{CE} [V]	V_{CE} [V]	I_C [A]	T_j [°C]	Min	Typ	Max	
Rated resistance	R					25		22		kΩ
Deviation of R100	$\Delta_{R/R}$	R100=1486 Ω				100	-12		+12	%
Power dissipation	P					25		200		mW
Power dissipation constant						25		2		mW/K
B-value	$B_{(25/50)}$	Tol. ±3%				25		3950		K
B-value	$B_{(25/100)}$	Tol. ±3%				25		3998		K
Vincotech NTC Reference									B	



Inverter Switch Characteristics

Typical output characteristics IGBT

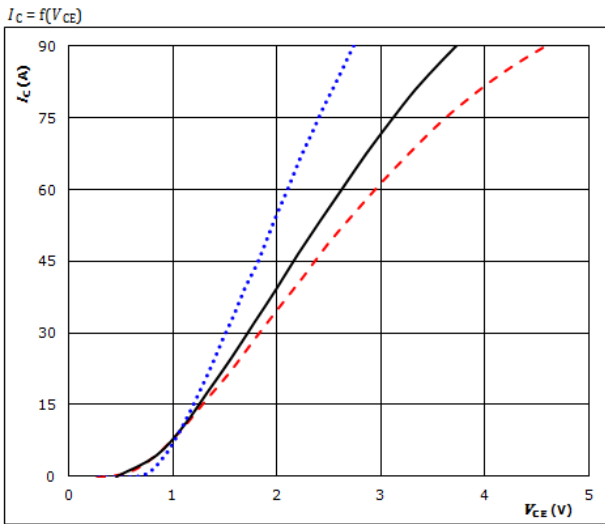

$t_p = 250 \mu s$
 $V_{CE} = 15 V$
25 °C
125 °C ———
150 °C - - - -

Typical output characteristics IGBT

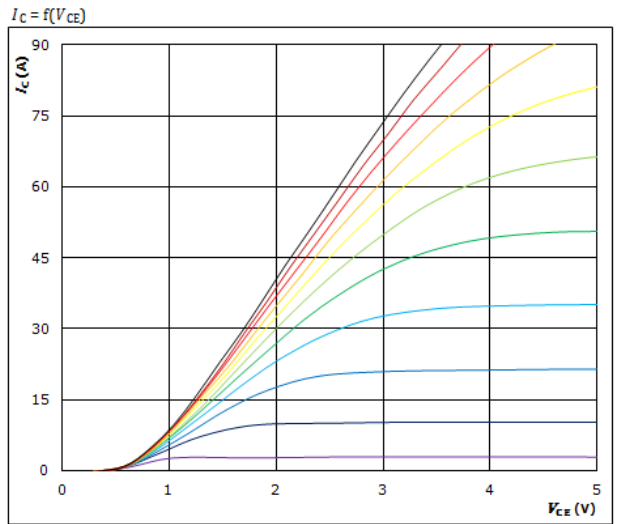

$t_p = 250 \mu s$
 $T_j = 150 \text{ } ^\circ C$
 V_{CE} from 7 V to 17 V in steps of 1 V

Typical transfer characteristics IGBT

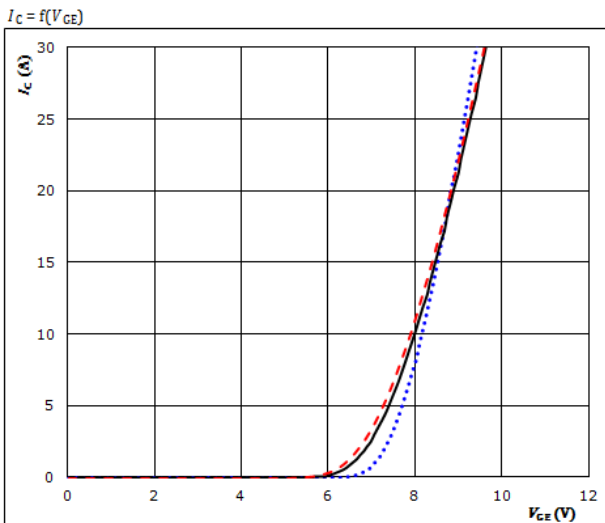

$t_p = 100 \mu s$
 $V_{CE} = 10 V$
25 °C
125 °C ———
150 °C - - - -

Transient Thermal Impedance as function of Pulse duration IGBT

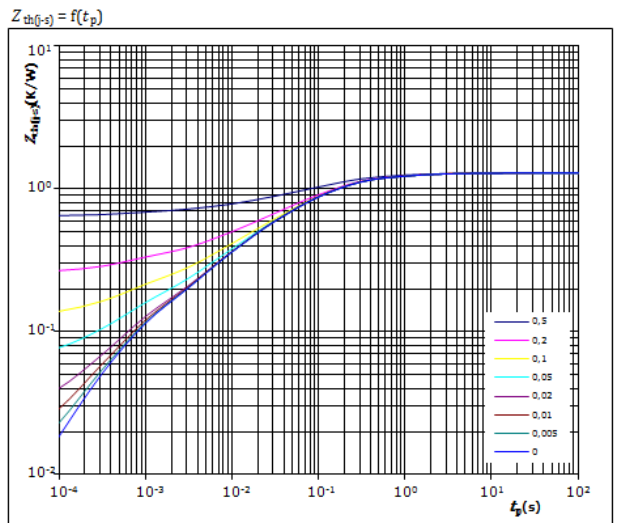

$D = t_p / T$
 $R_{th(j-s)} = 1,29 K/W$

IGBT thermal model values

R_{th} (K/W)	τ (s)
2,21E-02	9,93E+00
1,52E-01	1,02E+00
5,97E-01	1,46E-01
3,86E-01	3,59E-02
2,40E-01	7,53E-03
1,08E-01	6,03E-04



Inverter Switch Characteristics

Gate voltage vs Gate charge IGBT

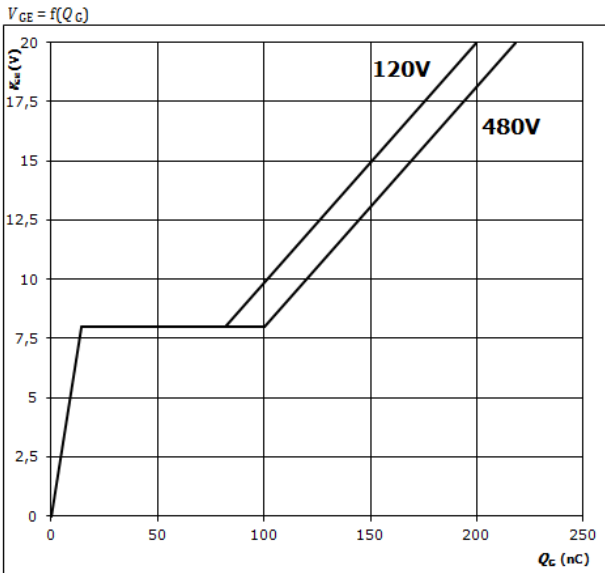

At
 $I_C = 30$ A

Short circuit duration as a function of V_{CE} IGBT

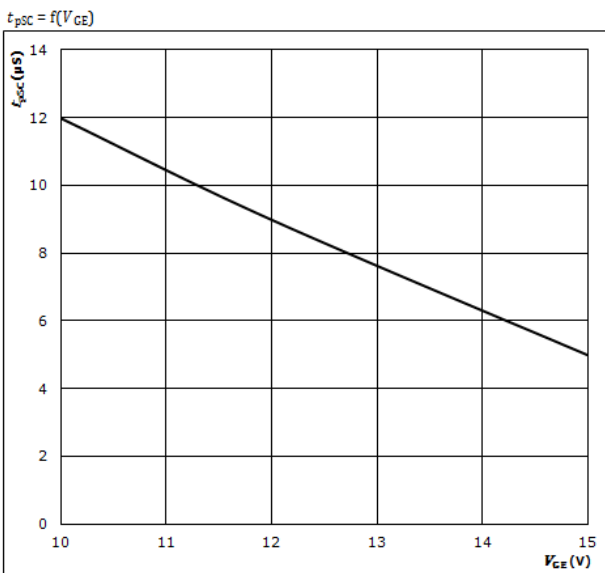

At
 $V_{CE} = 400$ V
 $T_j \leq 150$ °C

Typical short circuit current as a function of V_{CE} IGBT

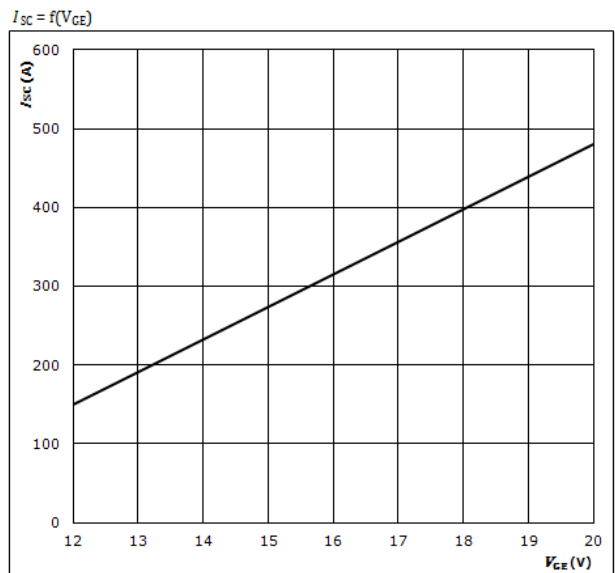

At
 $V_{CE} \leq 400$ V
 $T_j \leq 150$ °C



Inverter Diode Characteristics

Typical forward characteristics FWD

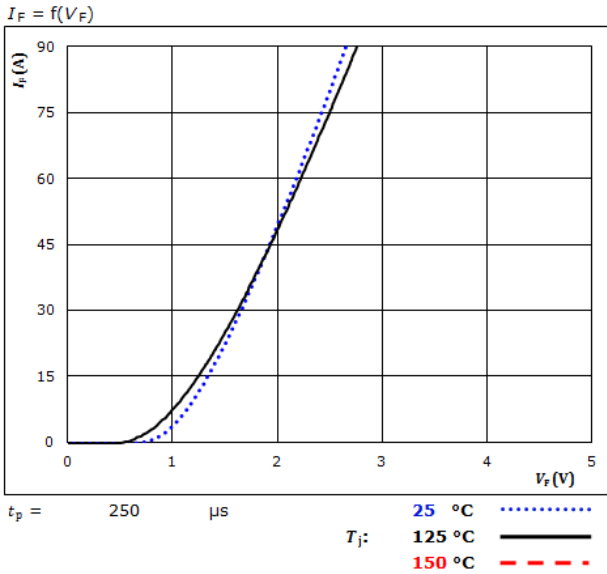

Transient thermal impedance as a function of pulse width FWD

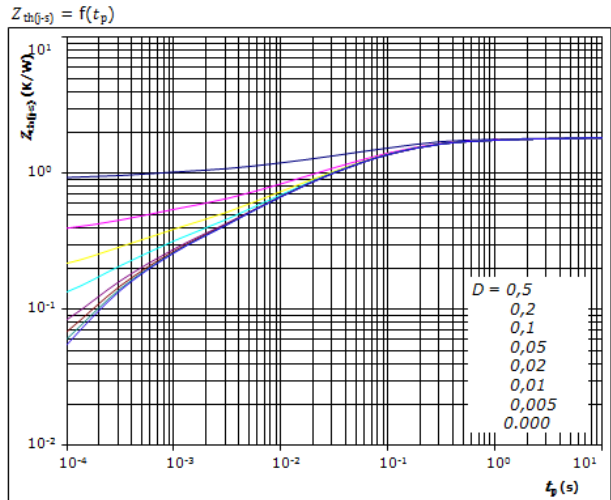

$D = t_p / T$
 $R_{th(0-t)} = 1,84 \text{ K/W}$

FWD thermal model values

R (K/W)	τ (s)
8,11E-02	3,72E+00
2,10E-01	4,02E-01
7,18E-01	8,35E-02
4,48E-01	1,56E-02
2,16E-01	2,93E-03
1,71E-01	3,31E-04



Brake Switch Characteristics

Typical output characteristics IGBT

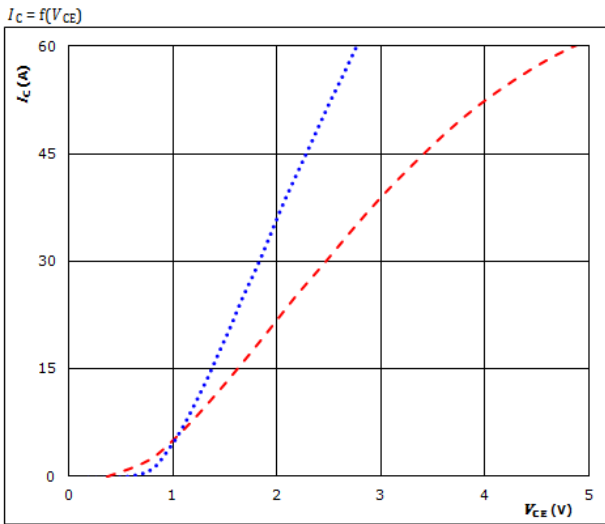

$t_p = 250 \mu s$
 $V_{CE} = 15 V$
 25 °C
 125 °C ———
 150 °C - - - -

Typical output characteristics IGBT

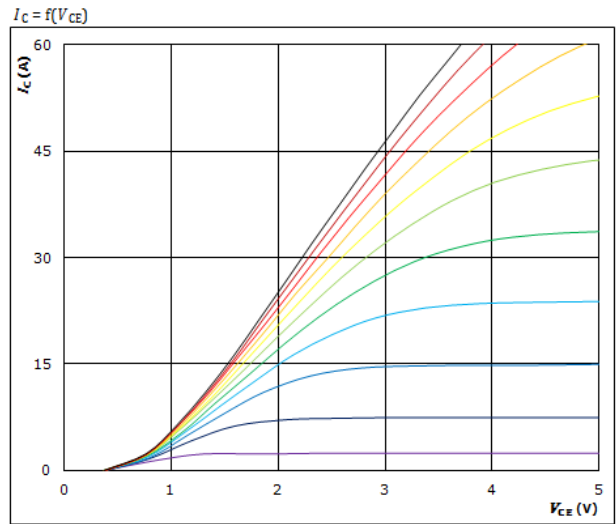

$t_p = 250 \mu s$
 $T_j = 150 \text{ °C}$
 V_{GE} from 7 V to 17 V in steps of 1 V

Typical transfer characteristics IGBT

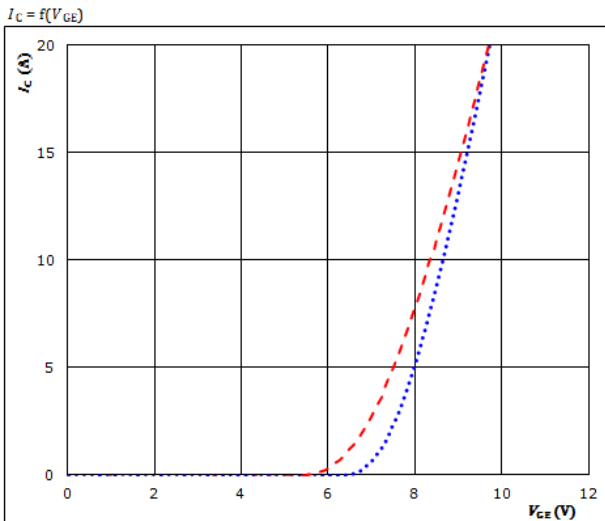

$t_p = 100 \mu s$
 $V_{CE} = 10 V$
 25 °C
 125 °C ———
 150 °C - - - -

Transient Thermal Impedance as function of Pulse duration IGBT

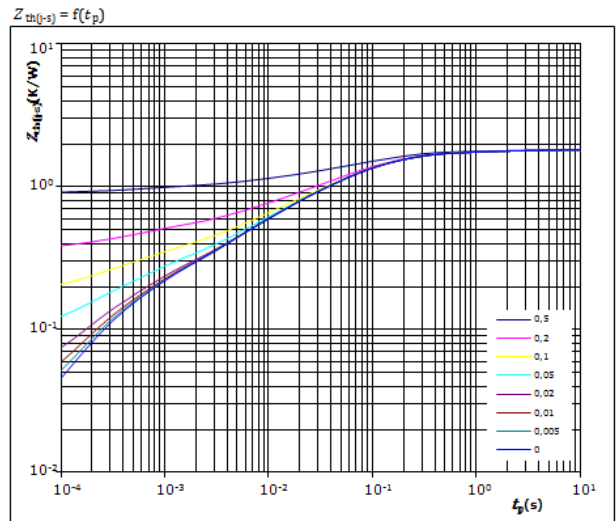

$D = t_p / T$
 $R_{th(j-s)} = 1,81 K/W$

IGBT thermal model values

$R_{th} (K/W)$	$\tau (s)$
6,63E-02	3,68E+00
1,83E-01	4,61E-01
8,24E-01	8,38E-02
3,93E-01	1,82E-02
1,96E-01	3,57E-03
1,49E-01	3,52E-04



Brake Switch Characteristics

Gate voltage vs Gate charge IGBT

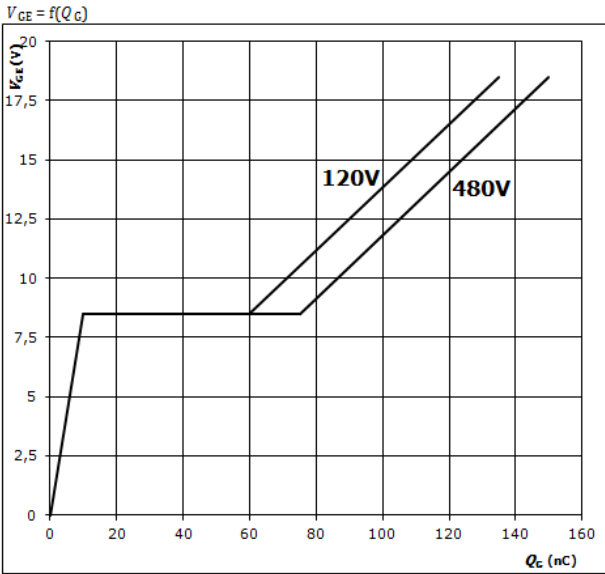

At
 $I_C = 20$ A

Short circuit duration as a function of V_{CE} IGBT

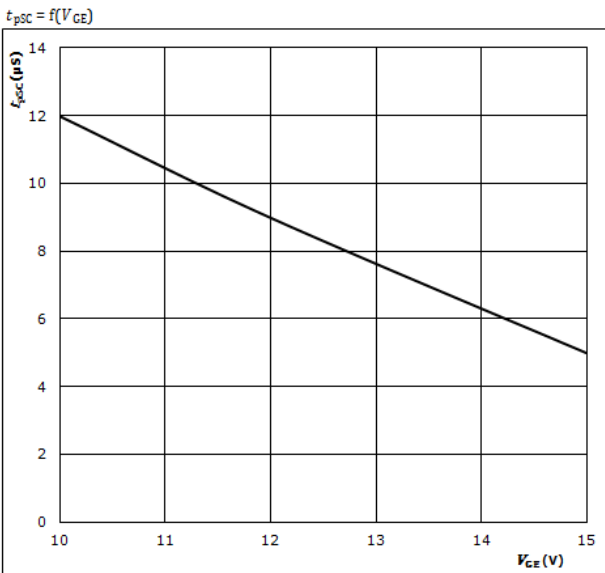

At
 $V_{CE} = 600$ V
 $T_j \leq 175$ °C

Typical short circuit current as a function of V_{CE} IGBT

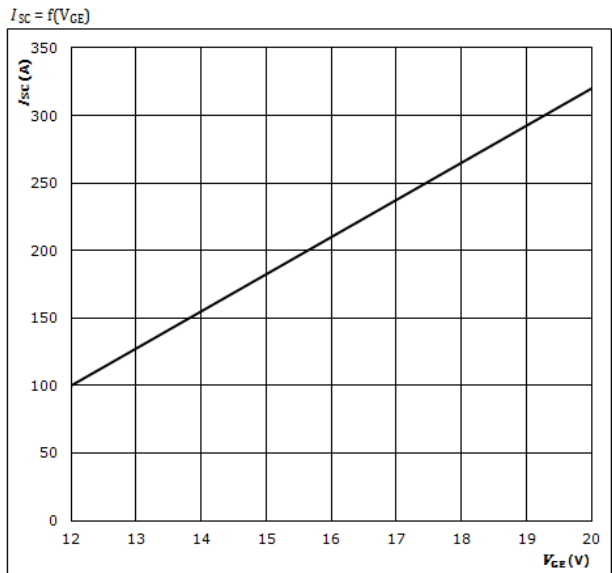

At
 $V_{CE} \leq 600$ V
 $T_j \leq 175$ °C



Brake Diode Characteristics

Typical forward characteristics FWD

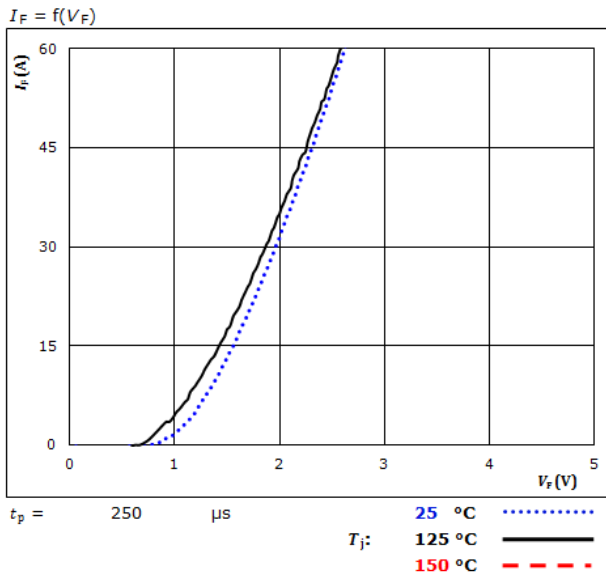

Transient thermal impedance as a function of pulse width FWD

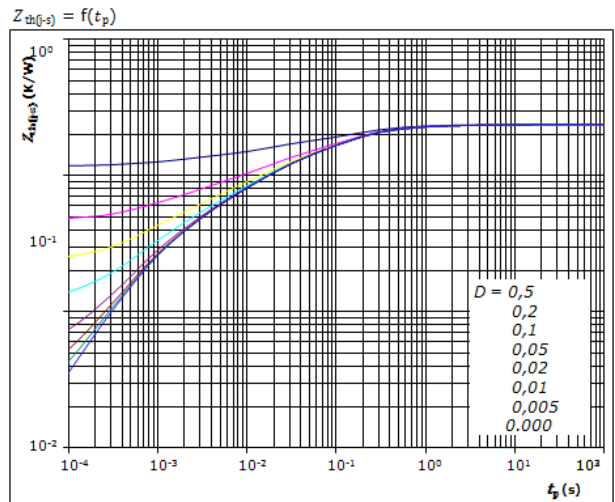

$D = \frac{t_p}{T}$
 $R_{th(j-s)} = 2,37 \text{ K/W}$

FWD thermal model values

R (K/W)	τ (s)
4,62E-02	8,95E+00
1,39E-01	1,10E+00
6,93E-01	1,96E-01
5,75E-01	6,44E-02
6,19E-01	9,95E-03
2,95E-01	1,01E-03



Rectifier Diode Characteristics

Typical forward characteristics Rectifier Diode

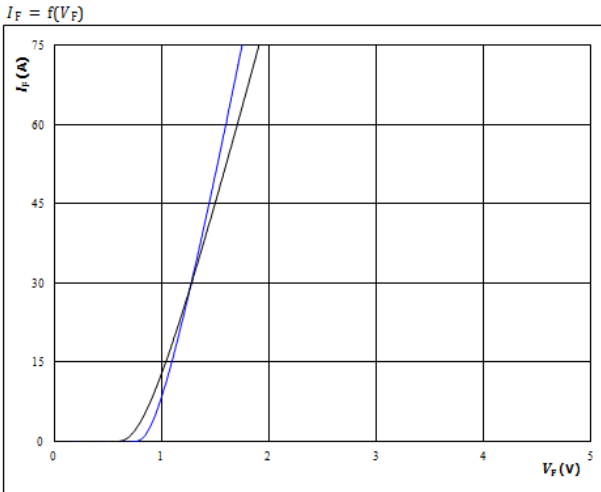

Transient thermal impedance as a function of pulse width Rectifier Diode

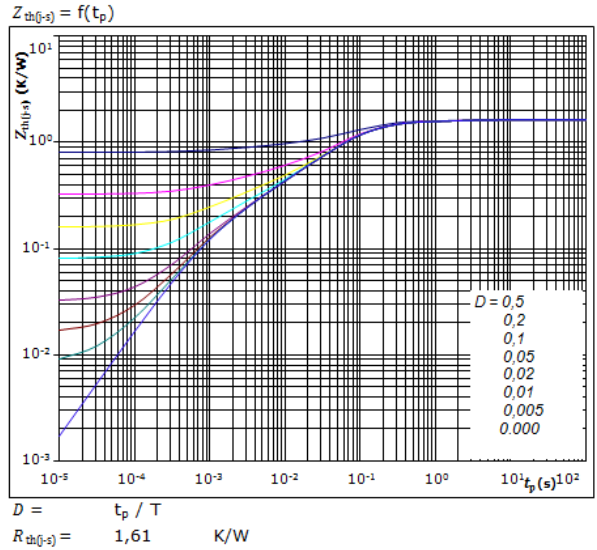

Rectifier Diode thermal model values

R (K/W)	τ (s)
6,72E-02	2,72E+00
1,48E-01	4,14E-01
8,68E-01	8,33E-02
2,53E-01	2,89E-02
1,69E-01	5,15E-03
1,06E-01	9,10E-04

Thermistor Characteristics

Thermistor typical temperature characteristic
Typical NTC characteristic
as a function of temperature

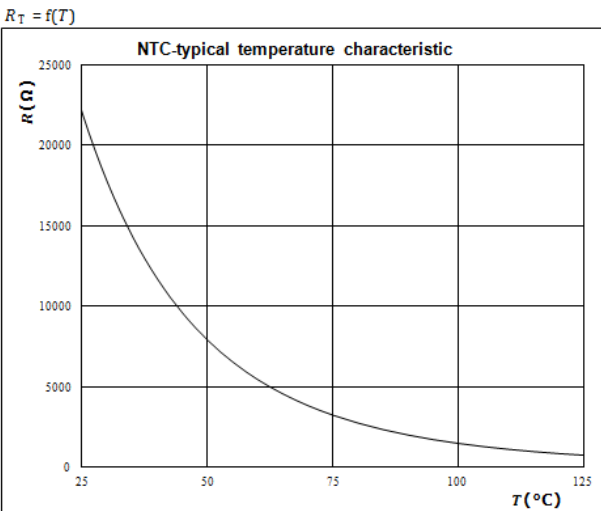



Inverter Switching Characteristics

Figure 1. IGBT

Typical switching energy losses as a function of collector current

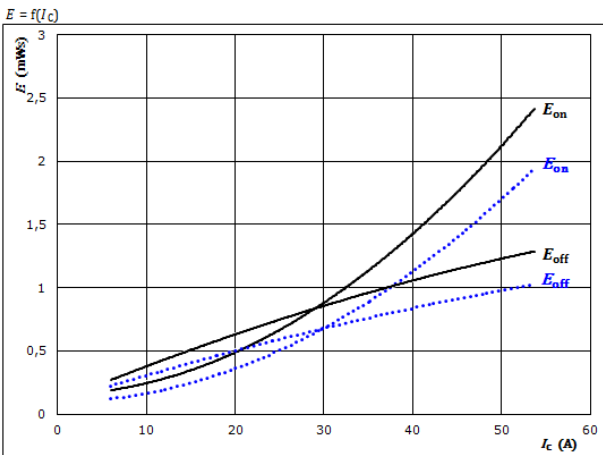

With an inductive load at

$V_{CE} = 300$ V	$T_j: 25$ °C
$V_{GE} = 15/0$ V	125 °C	————
$R_{gon} = 8$ Ω	150 °C	-----
$R_{goff} = 4$ Ω		

Figure 2. IGBT

Typical switching energy losses as a function of gate resistor

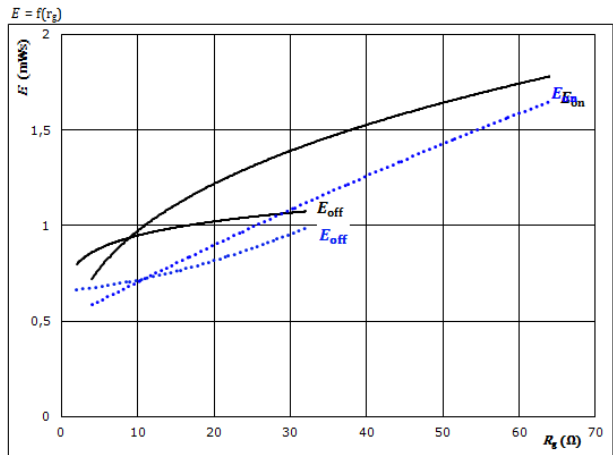

With an inductive load at

$V_{CE} = 300$ V	$T_j: 25$ °C
$V_{GE} = 15/0$ V	125 °C	————
$I_C = 30$ A	150 °C	-----

Figure 3. FWD

Typical reverse recovered energy loss as a function of collector current

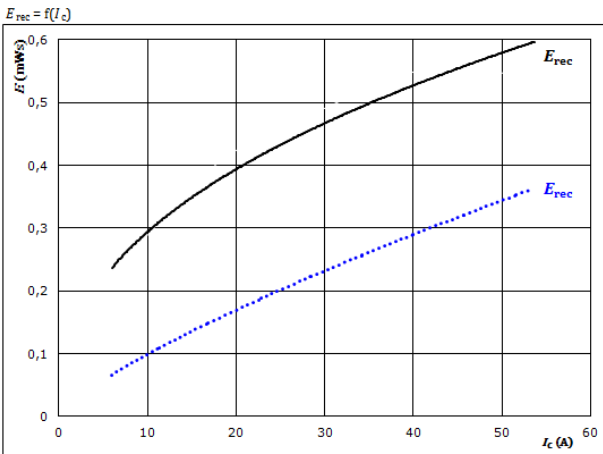

With an inductive load at

$V_{CE} = 300$ V	$T_j: 25$ °C
$V_{GE} = 15/0$ V	125 °C	————
$R_{gon} = 8$ Ω	150 °C	-----

Figure 4. FWD

Typical reverse recovered energy loss as a function of gate resistor

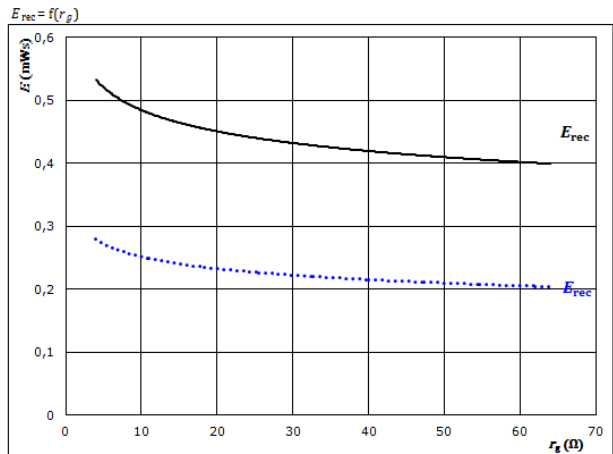

With an inductive load at

$V_{CE} = 300$ V	$T_j: 25$ °C
$V_{GE} = 15/0$ V	125 °C	————
$I_C = 30$ A	150 °C	-----



Inverter Switching Characteristics

Figure 5. IGBT

Typical switching times as a function of collector current

$$t = f(I_C)$$

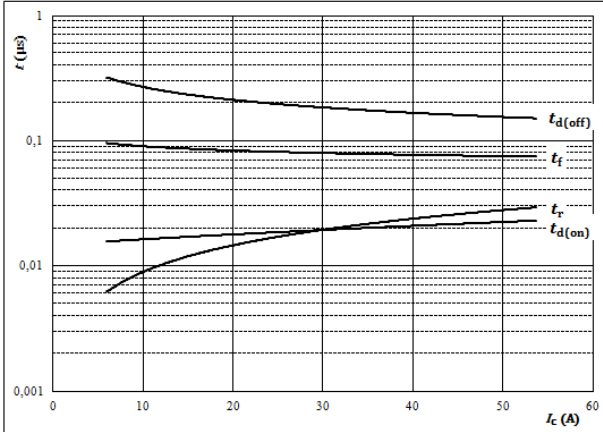

With an inductive load at

$T_j =$	125	°C
$V_{CE} =$	300	V
$V_{GE} =$	15/0	V
$R_{gon} =$	8	Ω
$R_{goff} =$	4	Ω

Figure 6. IGBT

Typical switching times as a function of gate resistor

$$t = f(r_g)$$

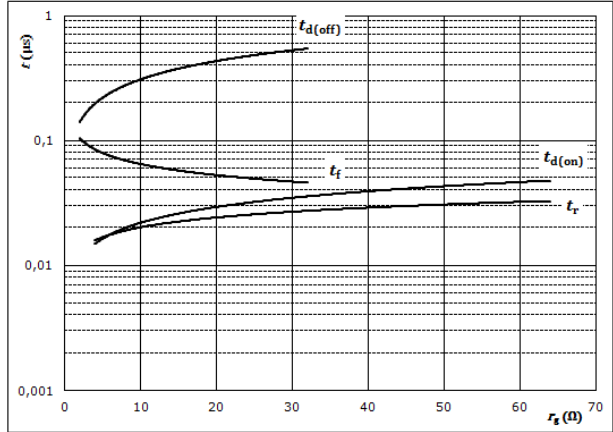

With an inductive load at

$T_j =$	125	°C
$V_{CE} =$	300	V
$V_{GE} =$	15/0	V
$I_C =$	30	A

Figure 7. FWD

Typical reverse recovery time as a function of collector current

$$t_{rr} = f(I_C)$$

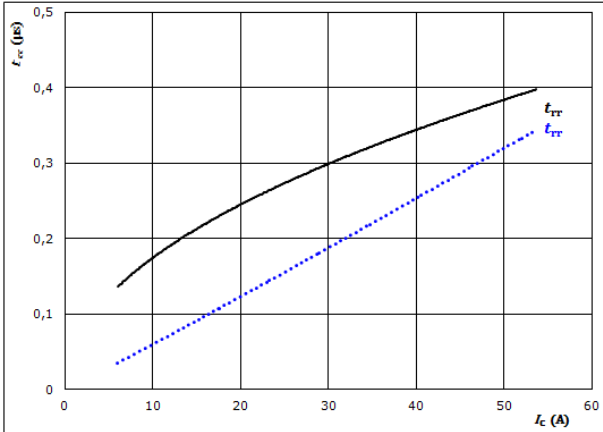

At	$V_{CE} =$	300	V	$T_j:$	25 °C
	$V_{CE} =$	15/0	V		125 °C	————
	$R_{gon} =$	8	Ω		150 °C	-----

Figure 8. FWD

Typical reverse recovery time as a function of IGBT turn on gate resistor

$$t_{rr} = f(R_{gon})$$

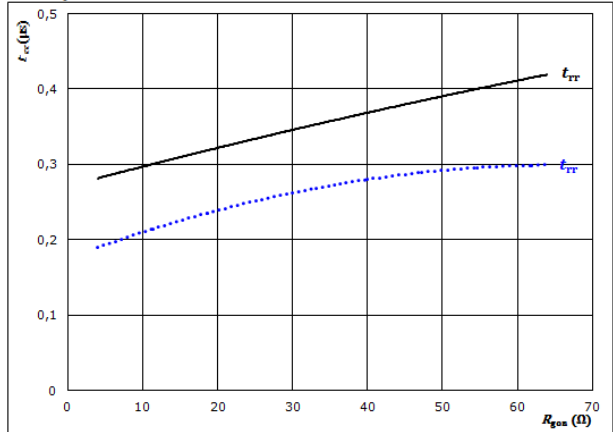

At	$V_{CE} =$	300	V	$T_j:$	25 °C
	$V_{CE} =$	15/0	V		125 °C	————
	$I_C =$	30	A		150 °C	-----



Inverter Switching Characteristics

Figure 9. FWD

Typical recovered charge as a function of collector current

$$Q_r = f(I_c)$$

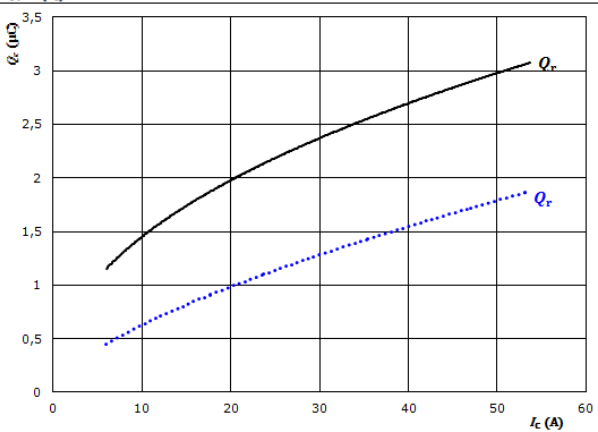

At $V_{CE} = 300$ V
 $V_{CE} = 15/0$ V
 $R_{gon} = 8$ Ω
 T_j : 25 °C (dotted blue), 125 °C (solid black), 150 °C (dashed red)

Figure 10. FWD

Typical recovered charge as a function of IGBT turn on gate resistor

$$Q_r = f(R_{gon})$$

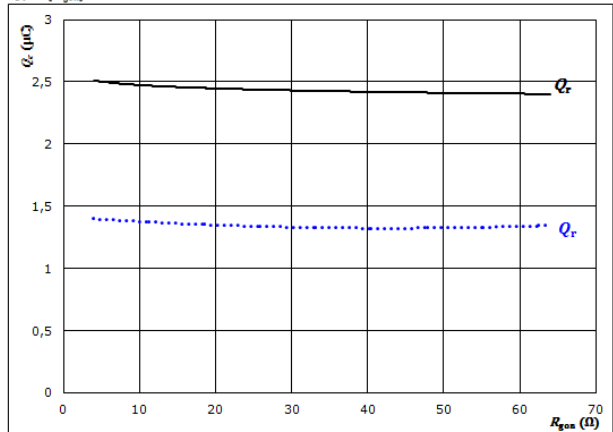

At $V_{CE} = 300$ V
 $V_{CE} = 15/0$ V
 $I_c = 30$ A
 T_j : 25 °C (dotted blue), 125 °C (solid black), 150 °C (dashed red)

Figure 11. FWD

Typical peak reverse recovery current as a function of collector current

$$I_{RM} = f(I_c)$$

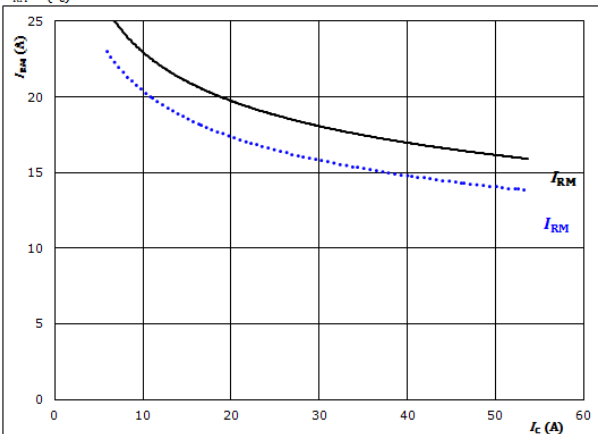

At $V_{CE} = 300$ V
 $V_{CE} = 15/0$ V
 $R_{gon} = 8$ Ω
 T_j : 25 °C (dotted blue), 125 °C (solid black), 150 °C (dashed red)

Figure 12. FWD

Typical peak reverse recovery current as a function of IGBT turn on gate resistor

$$I_{RM} = f(R_{gon})$$

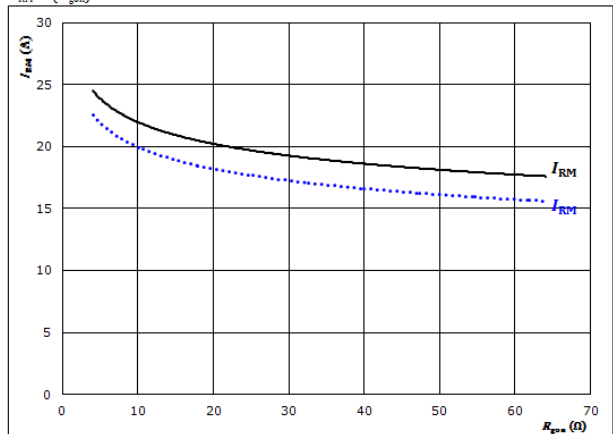

At $V_{CE} = 300$ V
 $V_{CE} = 15/0$ V
 $I_c = 30$ A
 T_j : 25 °C (dotted blue), 125 °C (solid black), 150 °C (dashed red)



Inverter Switching Characteristics

Figure 13. FWD

Typical rate of fall of forward and reverse recovery current as a function of collector current

$$di_F/dt, di_{rr}/dt = f(I_C)$$

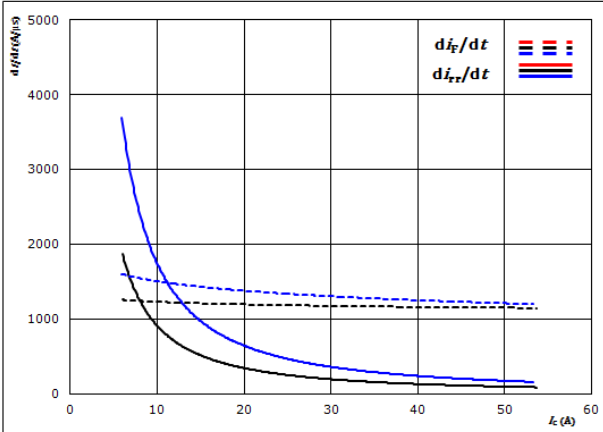

At $V_{CE} = 300$ V
 $V_{CE} = 15/0$ V
 $R_{gon} = 8$ Ω

T_j : 25 °C (dotted line)
 125 °C (solid line)
 150 °C (dashed line)

Figure 14. FWD

Typical rate of fall of forward and reverse recovery current as a function of IGBT turn on gate resistor

$$di_F/dt, di_{rr}/dt = f(R_g)$$

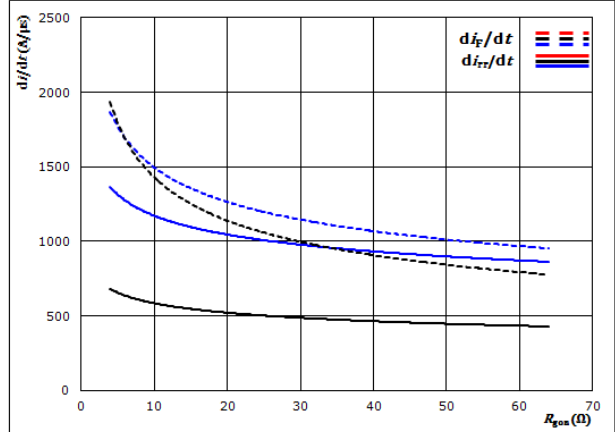

At $V_{CE} = 300$ V
 $V_{CE} = 15/0$ V
 $I_C = 30$ A

Figure 15. IGBT

Reverse bias safe operating area

$$I_C = f(V_{CE})$$

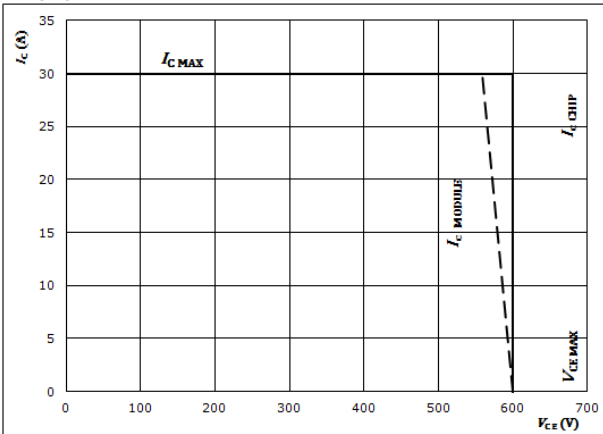

At $T_j = 175$ °C
 $R_{gon} = 8$ Ω
 $R_{goff} = 4$ Ω



Inverter Switching Characteristics

General conditions

T_j	=	125 °C
R_{gon}	=	8 Ω
R_{goff}	=	4 Ω

Figure 1. IGBT

Turn-off Switching Waveforms & definition of t_{doff} , t_{Eoff} (t_{Eoff} = integrating time for Eoff)

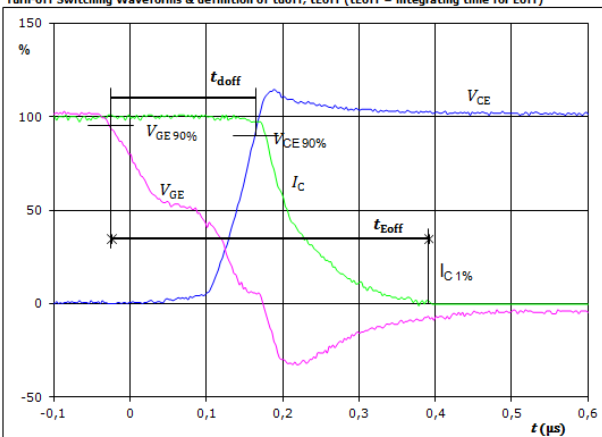

$V_{CE}(0\%) =$	0	V
$V_{CE}(100\%) =$	15	V
$V_C(100\%) =$	300	V
$I_C(100\%) =$	30	A
$t_{doff} =$	0,181	μs
$t_{Eoff} =$	0,416	μs

Figure 2. IGBT

Turn-on Switching Waveforms & definition of t_{don} , t_{Eon} (t_{Eon} = integrating time for Eon)

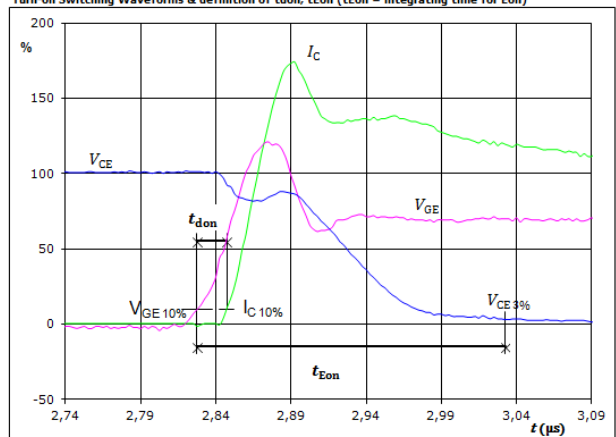

$V_{CE}(0\%) =$	0	V
$V_{CE}(100\%) =$	15	V
$V_C(100\%) =$	300	V
$I_C(100\%) =$	30	A
$t_{don} =$	0,019	μs
$t_{Eon} =$	0,205	μs

Figure 3. IGBT

Turn-off Switching Waveforms & definition of t_f

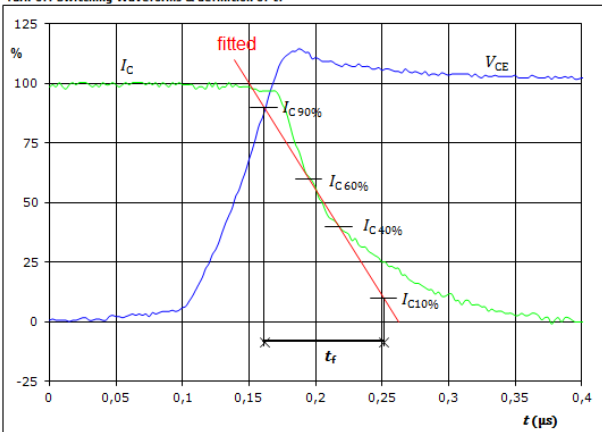

$V_C(100\%) =$	300	V
$I_C(100\%) =$	30	A
$t_f =$	0,085	μs

Figure 4. IGBT

Turn-on Switching Waveforms & definition of t_r

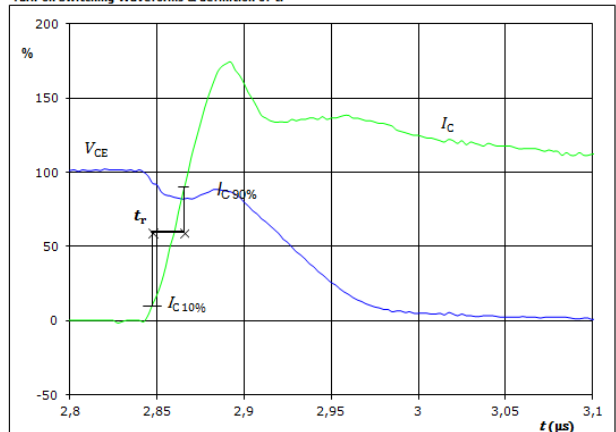

$V_C(100\%) =$	300	V
$I_C(100\%) =$	30	A
$t_r =$	0,019	μs



Inverter Switching Characteristics

Figure 5. IGBT

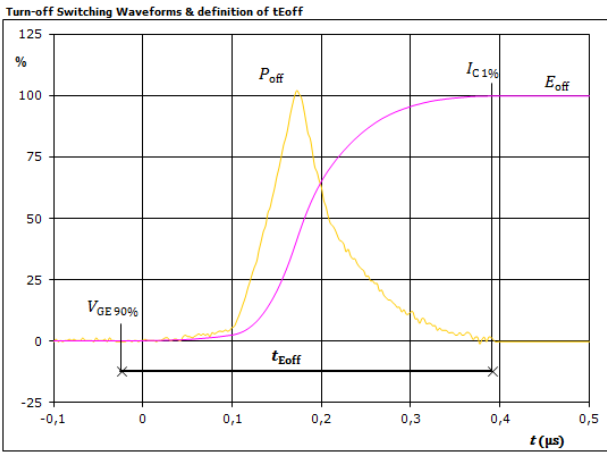

$P_{off}(100\%) = 8,98$ kW
 $E_{off}(100\%) = 0,85$ mJ
 $t_{Eoff} = 0,42$ μs

Figure 6. IGBT

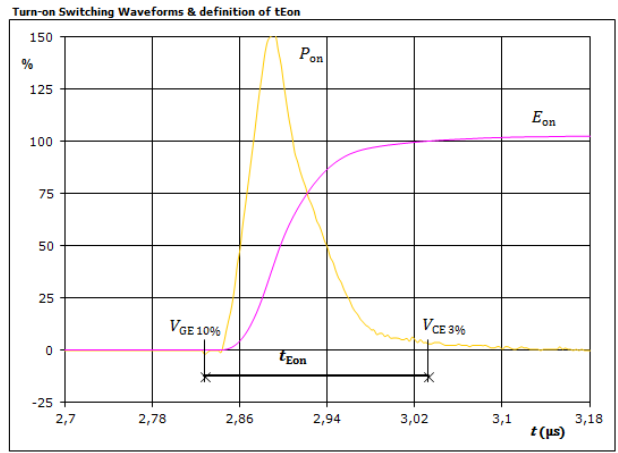

$P_{on}(100\%) = 8,98$ kW
 $E_{on}(100\%) = 0,88$ mJ
 $t_{Eon} = 0,21$ μs

Figure 7. FWD

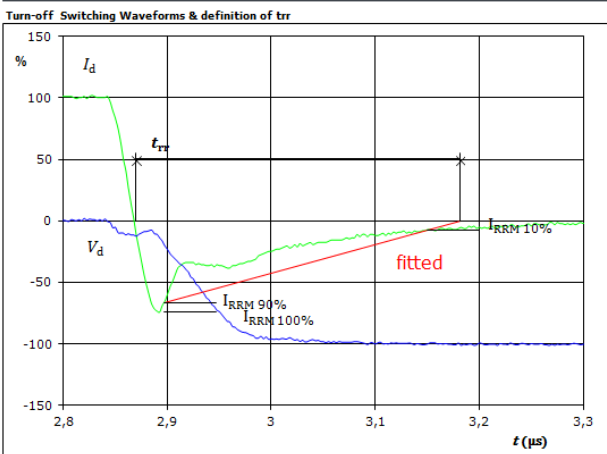

$V_d(100\%) = 300$ V
 $I_d(100\%) = 30$ A
 $I_{RRM}(100\%) = 22$ A
 $t_{rr} = 0,291$ μs



Inverter Switching Characteristics

Figure 8. FWD

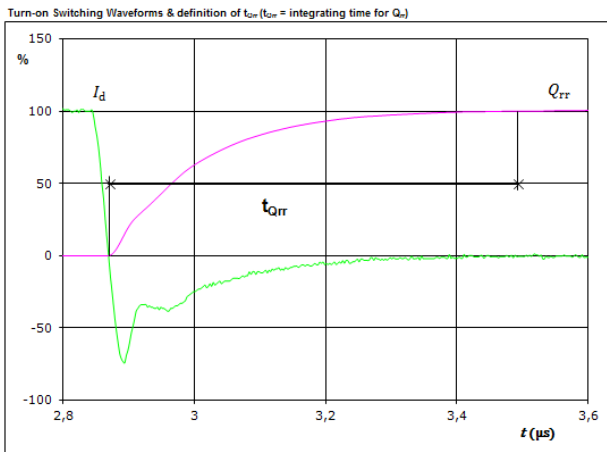
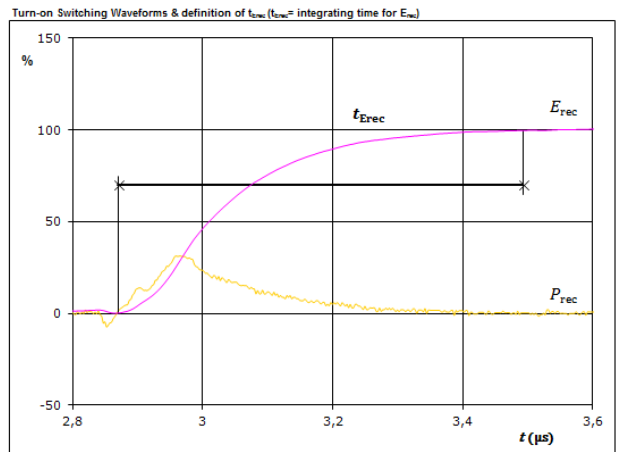

Figure 9. FWD





Brake Switching Characteristics

Figure 1. IGBT

Typical switching energy losses as a function of collector current

$$E = f(I_C)$$

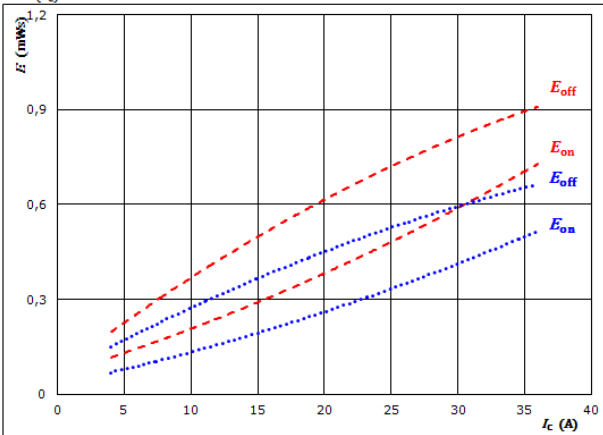

With an inductive load at

$V_{CE} =$	300 V	$T_j:$	25 °C
$V_{GE} =$	±15 V		125 °C	————
$R_{gon} =$	16 Ω		150 °C	-----
$R_{goff} =$	16 Ω			

Figure 2. IGBT

Typical switching energy losses as a function of gate resistor

$$E = f(r_g)$$

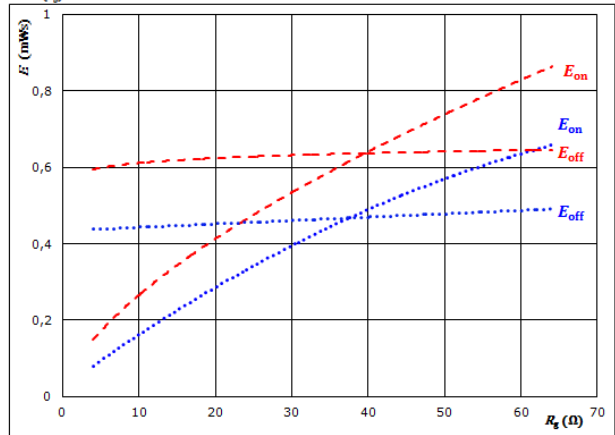

With an inductive load at

$V_{CE} =$	300 V	$T_j:$	25 °C
$V_{GE} =$	±15 V		125 °C	————
$I_C =$	20 A		150 °C	-----

Figure 3. FWD

Typical reverse recovered energy loss as a function of collector current

$$E_{rec} = f(I_C)$$

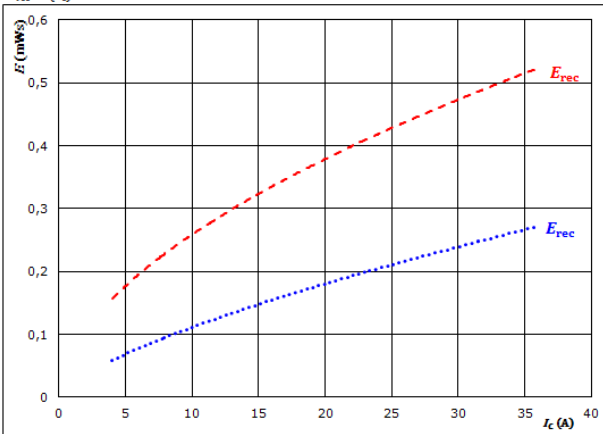

With an inductive load at

$V_{CE} =$	300 V	$T_j:$	25 °C
$V_{GE} =$	±15 V		125 °C	————
$R_{gon} =$	16 Ω		150 °C	-----

Figure 4. FWD

Typical reverse recovered energy loss as a function of gate resistor

$$E_{rec} = f(r_g)$$

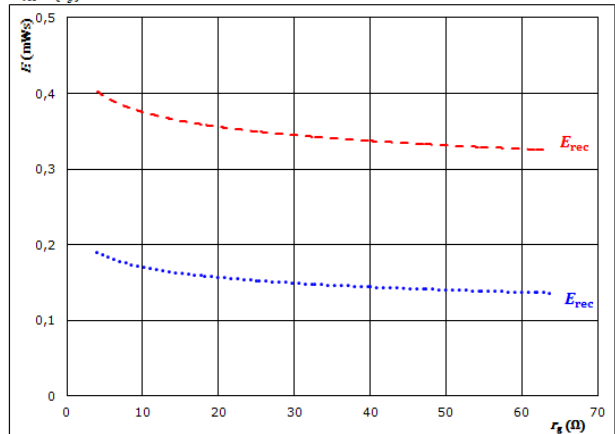

With an inductive load at

$V_{CE} =$	300 V	$T_j:$	25 °C
$V_{GE} =$	±15 V		125 °C	————
$I_C =$	20 A		150 °C	-----



Brake Switching Characteristics

Figure 5. IGBT

Typical switching times as a function of collector current

$$t = f(I_C)$$

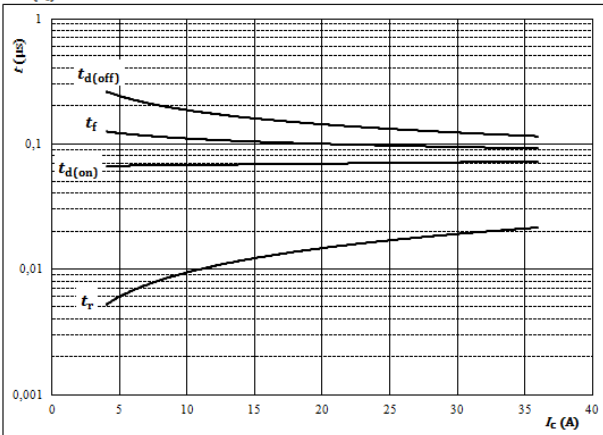

With an inductive load at

$T_j =$	150	°C
$V_{CE} =$	300	V
$V_{GE} =$	±15	V
$R_{gon} =$	16	Ω
$R_{goff} =$	16	Ω

Figure 6. IGBT

Typical switching times as a function of gate resistor

$$t = f(r_g)$$

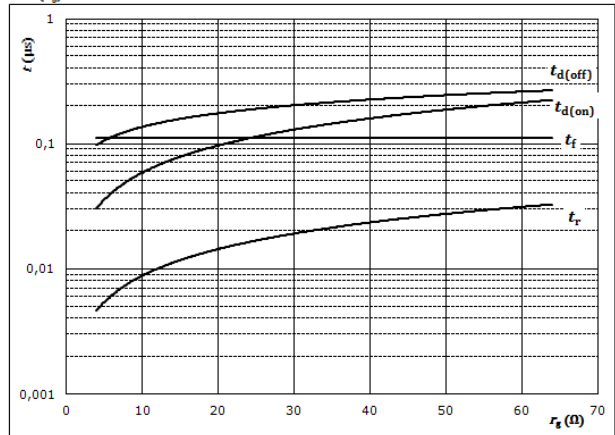

With an inductive load at

$T_j =$	150	°C
$V_{CE} =$	300	V
$V_{GE} =$	±15	V
$I_C =$	20	A

Figure 7. FWD

Typical reverse recovery time as a function of collector current

$$t_{rr} = f(I_C)$$

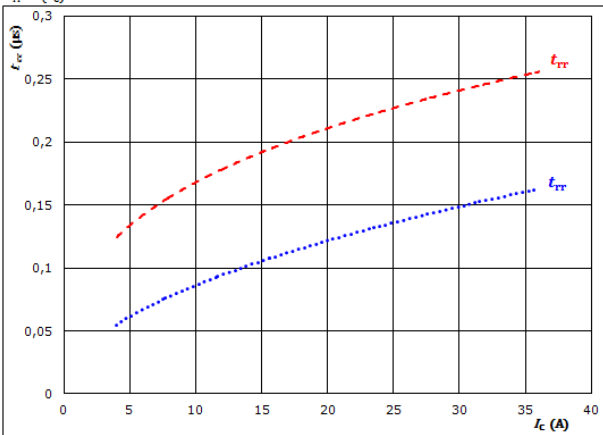

At	$V_{CE} =$	300	V	$T_j:$	25 °C
	$V_{GE} =$	±15	V		125 °C	————
	$R_{gon} =$	16	Ω		150 °C	-----

Figure 8. FWD

Typical reverse recovery time as a function of IGBT turn on gate resistor

$$t_{rr} = f(R_{gon})$$

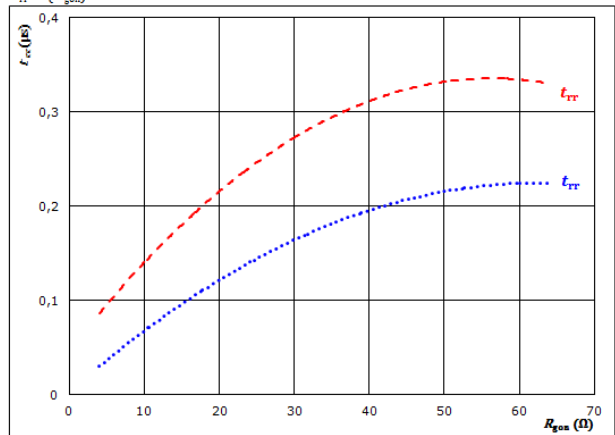

At	$V_{CE} =$	300	V	$T_j:$	25 °C
	$V_{GE} =$	±15	V		125 °C	————
	$I_C =$	20	A		150 °C	-----



Brake Switching Characteristics

Figure 9. FWD

Typical recovered charge as a function of collector current

$$Q_r = f(I_c)$$

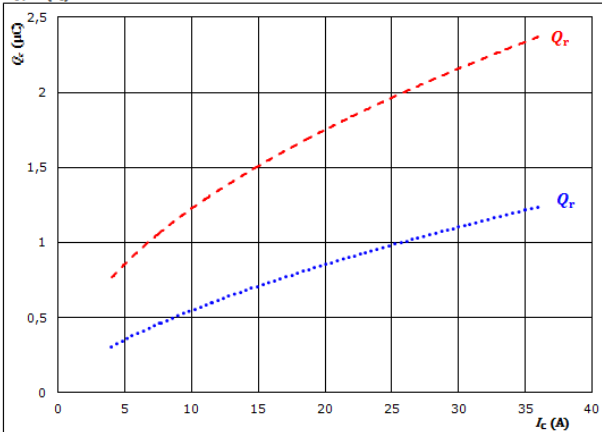

At $V_{CE} = 300$ V
 $V_{GE} = \pm 15$ V
 $R_{gon} = 16$ Ω
 T_j : 25 °C (dotted blue line)
 125 °C (solid black line)
 150 °C (dashed red line)

Figure 10. FWD

Typical recovered charge as a function of IGBT turn on gate resistor

$$Q_r = f(R_{gon})$$

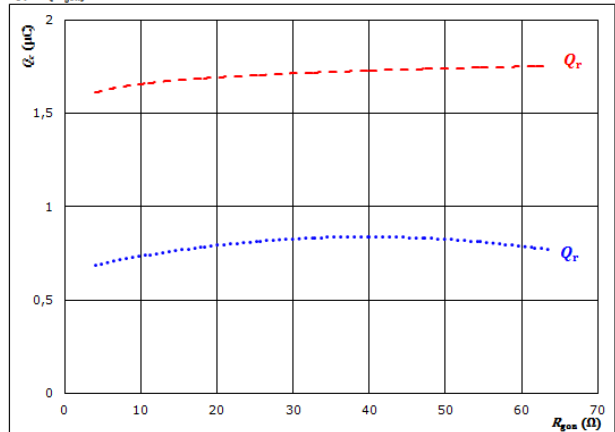

At $V_{CE} = 300$ V
 $V_{GE} = \pm 15$ V
 $I_c = 20$ A
 T_j : 25 °C (dotted blue line)
 125 °C (solid black line)
 150 °C (dashed red line)

Figure 11. FWD

Typical peak reverse recovery current as a function of collector current

$$I_{RM} = f(I_c)$$

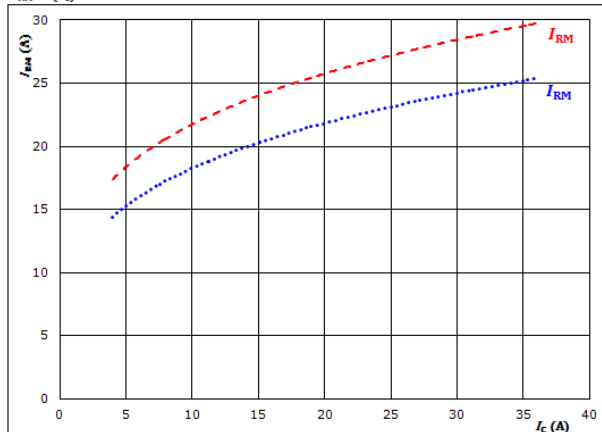

At $V_{CE} = 300$ V
 $V_{GE} = \pm 15$ V
 $R_{gon} = 16$ Ω
 T_j : 25 °C (dotted blue line)
 125 °C (solid black line)
 150 °C (dashed red line)

Figure 12. FWD

Typical peak reverse recovery current as a function of IGBT turn on gate resistor

$$I_{RM} = f(R_{gon})$$

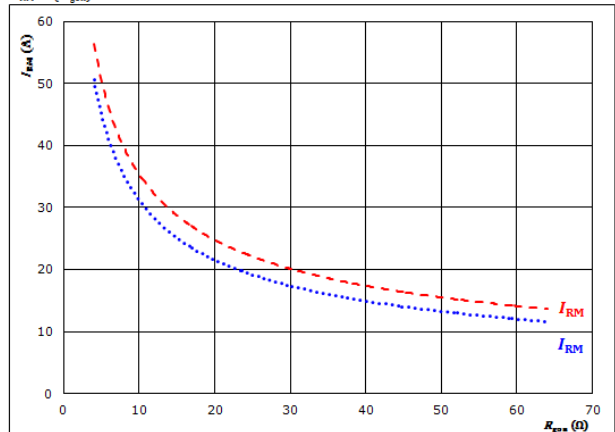

At $V_{CE} = 300$ V
 $V_{GE} = \pm 15$ V
 $I_c = 20$ A
 T_j : 25 °C (dotted blue line)
 125 °C (solid black line)
 150 °C (dashed red line)



Brake Switching Characteristics

Figure 13. FWD

Typical rate of fall of forward and reverse recovery current as a function of collector current
 $di_F/dt, di_{rr}/dt = f(I_C)$

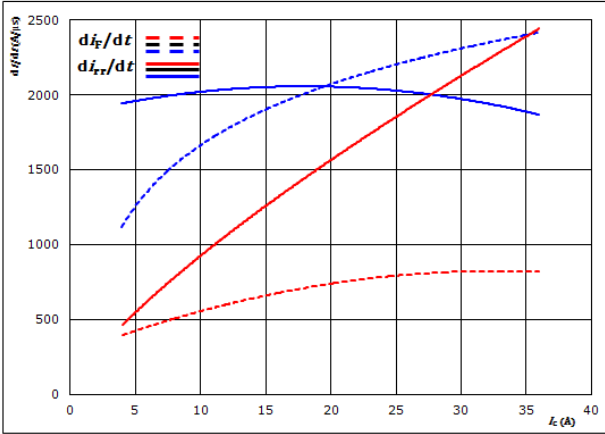

At $V_{CE} = 300$ V
 $V_{GE} = \pm 15$ V
 $R_{gon} = 16$ Ω
 $T_j = 25$ °C
 125 °C
 150 °C

Figure 14. FWD

Typical rate of fall of forward and reverse recovery current as a function of IGBT turn on gate resistor
 $di_F/dt, di_{rr}/dt = f(R_{g})$

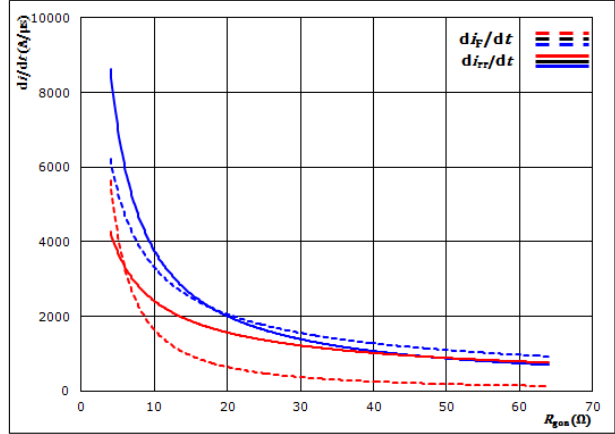

At $V_{CE} = 300$ V
 $V_{GE} = \pm 15$ V
 $I_C = 20$ A
 $T_j = 25$ °C
 125 °C
 150 °C

Figure 15. IGBT

Reverse bias safe operating area

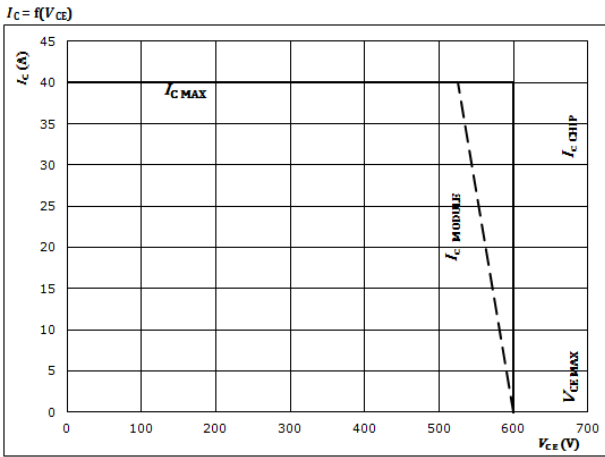

At $T_j = 175$ °C
 $R_{gon} = 16$ Ω
 $R_{goff} = 16$ Ω



Brake Switching Characteristics

General conditions

T_j	=	150 °C
R_{gon}	=	16 Ω
R_{goff}	=	16 Ω

Figure 1. IGBT

Turn-off Switching Waveforms & definition of t_{doff} , t_{Eoff} (t_{Eoff} = integrating time for E_{off})

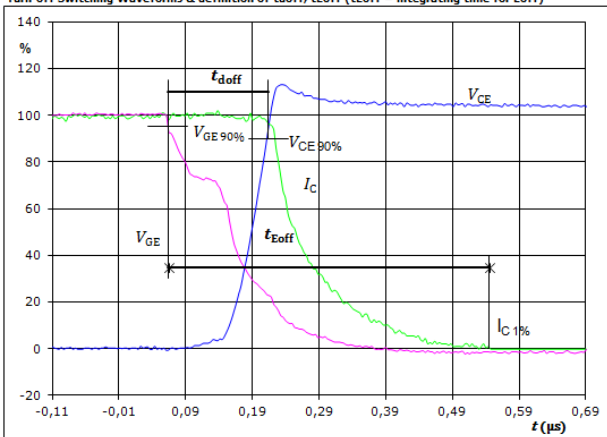

$V_{GE}(0\%) =$	-15	V
$V_{GE}(100\%) =$	15	V
$V_C(100\%) =$	300	V
$I_C(100\%) =$	20	A
$t_{doff} =$	0,143	μs
$t_{Eoff} =$	0,482	μs

Figure 3. IGBT

Turn-off Switching Waveforms & definition of t_f

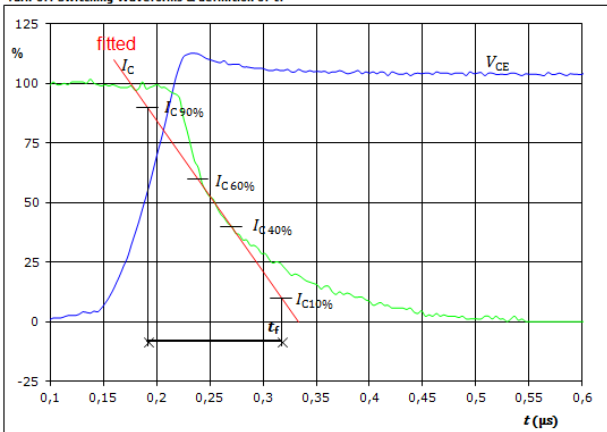

$V_C(100\%) =$	300	V
$I_C(100\%) =$	20	A
$t_f =$	0,110	μs

Figure 2. IGBT

Turn-on Switching Waveforms & definition of t_{don} , t_{Eon} (t_{Eon} = integrating time for E_{on})

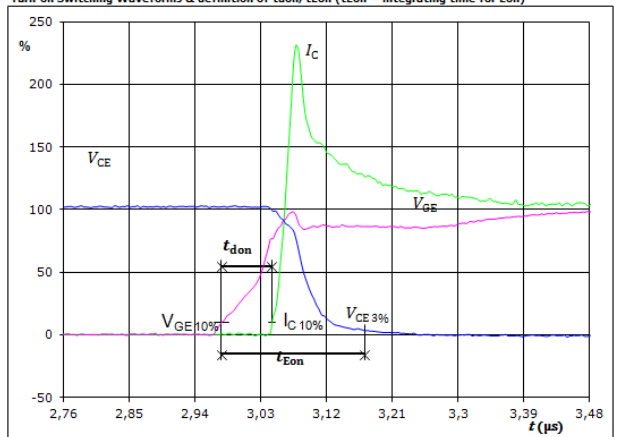

$V_{GE}(0\%) =$	-15	V
$V_{GE}(100\%) =$	15	V
$V_C(100\%) =$	300	V
$I_C(100\%) =$	20	A
$t_{don} =$	0,070	μs
$t_{Eon} =$	0,196	μs

Figure 4. IGBT

Turn-on Switching Waveforms & definition of t_r

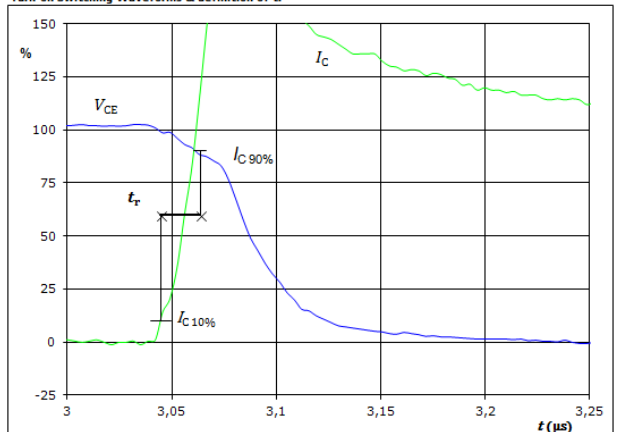

$V_C(100\%) =$	300	V
$I_C(100\%) =$	20	A
$t_r =$	0,016	μs



Brake Switching Characteristics

Figure 5. IGBT

Turn-off Switching Waveforms & definition of t_{Eoff}

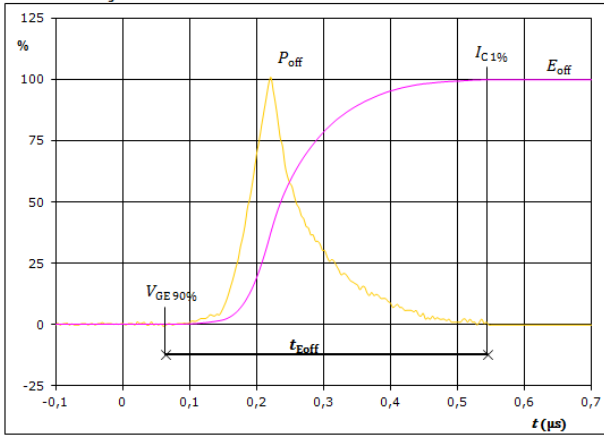

$P_{off}(100\%) = 5,98$ kW
 $E_{off}(100\%) = 0,61$ mJ
 $t_{Eoff} = 0,48$ μs

Figure 6. IGBT

Turn-on Switching Waveforms & definition of t_{Eon}

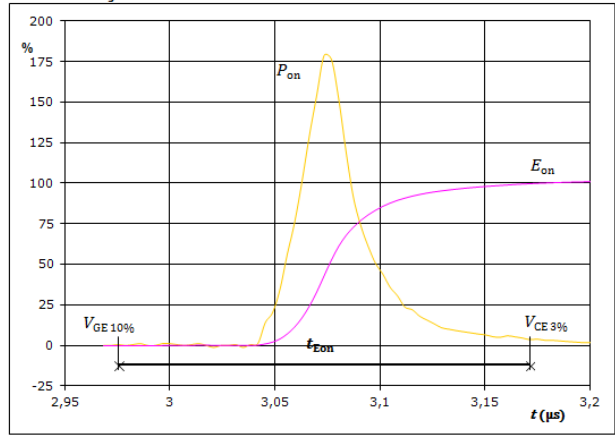

$P_{on}(100\%) = 5,98$ kW
 $E_{on}(100\%) = 0,38$ mJ
 $t_{Eon} = 0,20$ μs

Figure 7. FWD

Turn-off Switching Waveforms & definition of t_{rr}

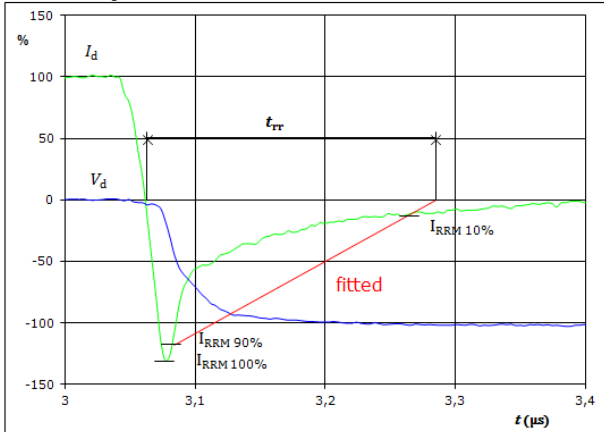

$V_d(100\%) = 300$ V
 $I_d(100\%) = 20$ A
 $I_{RRM}(100\%) = -26$ A
 $t_{rr} = 0,204$ μs



Brake Switching Characteristics

Figure 8. FWD

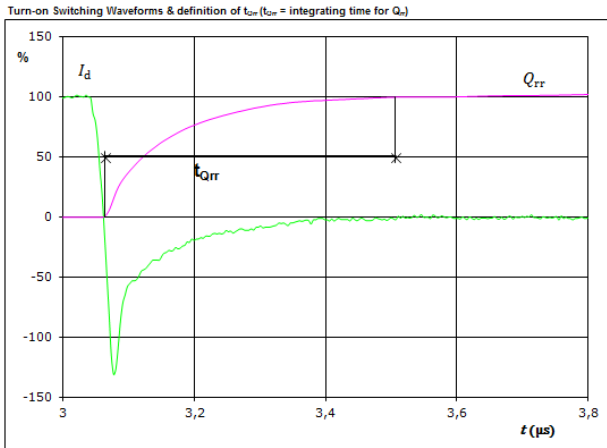

$I_d(100\%) =$	20	A
$Q_{rr}(100\%) =$	1,71	μC
$t_{Qrr} =$	0,44	μs

Figure 9. FWD

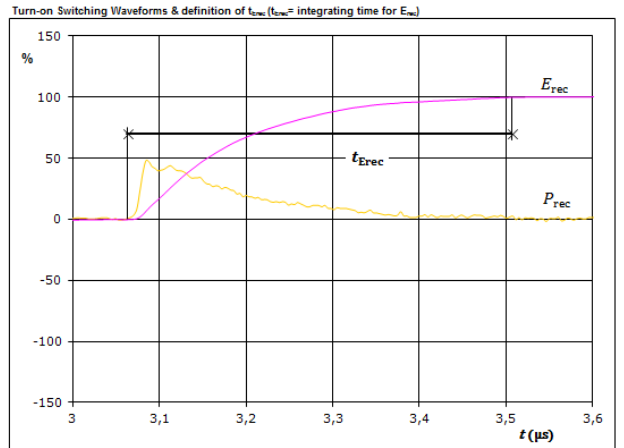

$P_{rec}(100\%) =$	5,98	kW
$E_{rec}(100\%) =$	0,37	mJ
$t_{Erec} =$	0,44	μs



Vincotech

Ordering Code & Marking								
Version	Ordering Code	in DataMatrix as		in packaging barcode as				
without thermal paste with solder pins	V23990-P635-A-PM	P635-A		P635-A				
Vinco WWWW NNNNNNVV UL LLLL SSSS		Text	Vinco	Date code	Name&Ver	UL	Lot	Serial
			Vinco	WWYY	NNNNNNVV	UL	LLLL	SSSS
		Datamatrix	Type&Ver	Lot number	Serial	Date code		
		TTTTTTVV	LLLL	SSSS	WWYY			

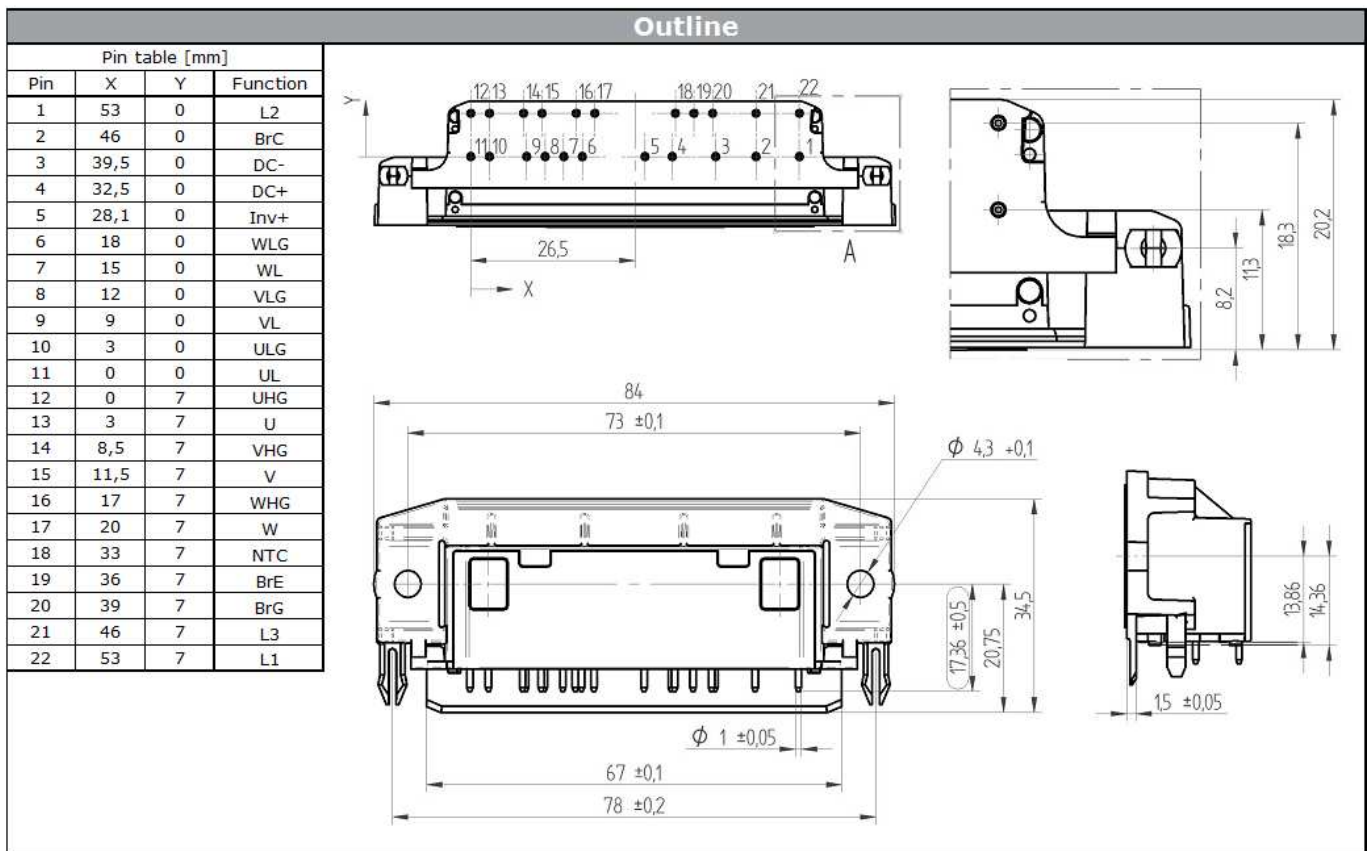



Vincotech

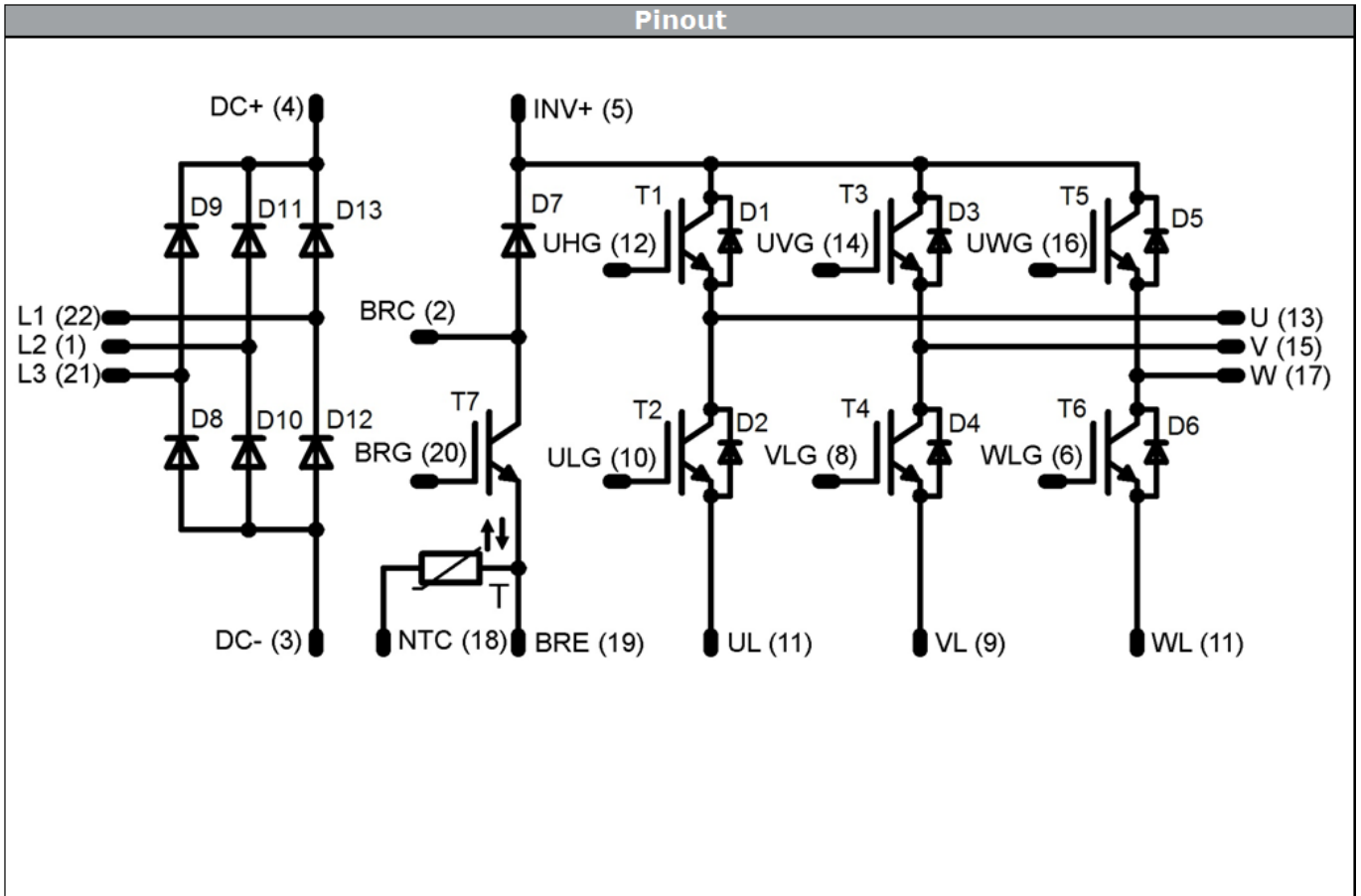

Identification					
ID	Component	Voltage	Current	Function	Comment
T1,T2,T3,T4,T5,T6	IGBT	600V	30A	Inverter Switch	
D1,D2,D3,D4,D5,D6	FWD	600V	30A	Inverter Diode	
T7	IGBT	600V	20A	Brake Switch	
D7	FWD	600V	20A	Brake Diode	
D8,D9,D10, D11,D12,D13	Rectifier	1600V	25A	Rectifier Diode	
T	NTC	-	-	Thermistor	



Vincotech

Packaging instruction					
Standard packaging quantity (SPQ)	80	>SPQ	Standard	<SPQ	Sample

Handling instruction
Handling instructions for <i>flow</i> 90 1 packages see vincotech.com website.

Document No.:	Date:	Modification:	Pages
V23990-P635A-D2-14	17 Mar. 2015		

DISCLAIMER

The information given in this datasheet describes the type of component and does not represent assured characteristics. For tested values please contact Vincotech. Vincotech reserves the right to make changes without further notice to any products herein to improve reliability, function or design. Vincotech does not assume any liability arising out of the application or use of any product or circuit described herein; neither does it convey any license under its patent rights, nor the rights of others.

LIFE SUPPORT POLICY

Vincotech products are not authorised for use as critical components in life support devices or systems without the express written approval of Vincotech.

As used herein:

1. Life support devices or systems are devices or systems which, (a) are intended for surgical implant into the body, or (b) support or sustain life, or (c) whose failure to perform when properly used in accordance with instructions for use provided in labelling can be reasonably expected to result in significant injury to the user.
2. A critical component is any component of a life support device or system whose failure to perform can be reasonably expected to cause the failure of the life support device or system, or to affect its safety or effectiveness.